

Pneumatic Test Program – Test (OSB)

Preliminary work:

Diagnosis - Diagnostic Trouble Code (DTC) Memory 11 PSE
 PSE control module voltage supply 23 PSE ⇒ 1.0
 PSE Control Module Test 32 PSE

Data (mbar)

	OSB 1 – 2 seats (front)	OSB 4 seats (front and rear)
Allowable system leakage per circuit at 600 mbar pressure in 1 minute	30 mbar	60 mbar

Special Tools

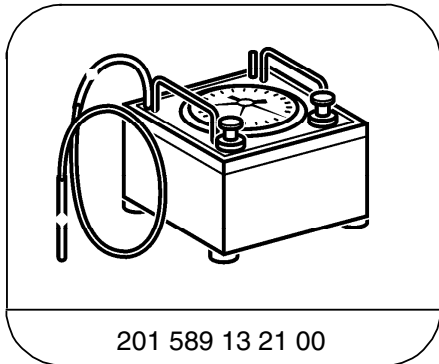

201 589 13 21 00

Tester

Pneumatic Test Program – Test (OSB)

A. Entire system

Preparation for Test:

Vehicles up to 07/94:

1. Disconnect pneumatic multiple connector from PSE control module.
2. Connect tester to bottom side of pneumatic multiple connector at

PÜ using connector 129 805 04 44.

Vehicles as of 08/94:

1. Disconnect **grey** pneumatic line with socket from PSE control module.
2. Connect tester to disconnected pneumatic line using connector 129 805 04 44.

Parts Required for Test:

1	Connector	129 805 04 44
2	Connector, 50 mm long	007 997 61 82
1	Pneumatic line, 1 m long	000 158 14 35

Note:

The connections on the PSE control module and pneumatic multiple connector are marked with their German acronyms. In other words:

ZV (German) = **CL** (English),
RH (German) = **BA** (English),
FKS (German) = **RHR** (English),
SFG (German) = **RTG** (English),
PÜ/P+ (OSL) (German) = **PÜ/P+ (OSB)** (English),
PU/P- (SRU) (German) = **PU/P- (MVA)** (English).

⇒	Test scope	Test connection	Test condition	Nominal value	Possible cause/Remedy
1.0	Complete lumbar support system pressurized	Yellow connector on tester.	Apply 600 mbar pressure to entire system. Set adjuster to position 5.	Pressure loss 30 mbar in 1 minute.	33 PSE ⇒ 1.0, 32 ⇒ 3.0, 4.0, 8.0
2.0	Complete multi-contour backrest system pressurized in each of the 3 height positions with maximum side bolster setting	Yellow connector on tester.	Apply 600 mbar pressure in each of the 3 height settings. Set adjuster to position 5, Side bolster rocker switch to maximum.	Pressure loss in each height setting 30 mbar in 1 minute.	33 PSE ⇒ 1.0, 32 ⇒ 3.0, 4.0, 8.0

Pneumatic Test Program – Test (OSB)

B. Line with pressure reservoir/line with control valve

Preparation for Test:

Vehicles up to 07/94:

1. Pry off **grey** orthopedic seat backrest (OSB) pneumatic line at pneumatic multiple connector (using a 7 mm open end wrench).
2. Connect tester in sequence to each of the **grey** OSB pneumatic lines which lead to either the pressure reservoir in the trunk or one of the two control valves at the front seats using connector 007 997 61 82.

Vehicles as of 08/94:

1. Disconnect **grey** OSB pneumatic lines at pneumatic distributor.

Letters on the distributor indicate where the pneumatic lines lead to.

- A → Vacuum reservoir B → Left front seat
 C → Right front seat

On vehicles as of approx. 06/94, the disconnected pneumatic lines are to be reconnected to the distributor with connector 007 997 61 82.

Parts Required for Test:

- 1 Connector, 50 mm long 007 997 61 82

⇒	Test scope	Test connection	Test condition	Nominal value	Possible cause/Remedy
3.0	Line and reservoir holding pressure	Yellow connector on tester.	Apply 600 mbar pressure to line and pressure reservoir.	Pressure drop 5 mbar in 1 minute.	32 ⇒ 7.0, Reservoir leaks. Replace reservoir.
4.0	Line and control valve holding pressure	Yellow connector on tester.	Apply 600 mbar pressure to line and control valve. Set adjuster to position 0. (On vehicles with multi-contour seat back, set rocker switch to minimum).	Pressure drop 5 mbar in 1 minute.	32 ⇒ 5.0, 6.0, 7.0

Pneumatic Test Program – Test (OSB)

C. Control valve

Preparation for Test:

1. Remove control valve for lumbar support or multi-contour backrest.
2. Cap all connections on control valve except connection **P** with caps, part no. 000 987 29 45.
3. Connect vacuum/pressure tester to connection **P** of control valve.

Parts Required for Test:

- | | | |
|---|-----------------------|---------------|
| 5 | Caps | 000 987 29 45 |
| 1 | Connector, 50 mm long | 007 997 61 82 |

⇒	Test scope	Test connection	Test condition	Nominal value	Possible cause/Remedy
5.0	Control valve for lumbar support pressurized	Yellow connector on tester.	Apply 600 mbar pressure to control valve. Set adjuster to 0.	Pressure drop 5 mbar in 1 minute.	Control valve leaks. Replace control valve.
6.0	Control valve for multi-contour backrest system pressurized in each of the 3 height positions	Yellow connector on tester.	Apply 600 mbar pressure to control valve. Set adjuster to 0. Side bolster rocker switch to minimum.	Pressure drop 5 mbar in 1 minute.	Control valve leaks. Replace control valve.

Pneumatic Test Program – Test (OSB)

D. Lines

Preparation for Test:

1. Connect tester to one end of pneumatic line and plug other end with cap, part no. 000 987 29 45.

Parts Required for Test:

- | | | |
|---|-----------------------|---------------|
| 1 | Cap | 000 987 29 45 |
| 1 | Connector, 50 mm long | 007 997 61 82 |
| 1 | Connector | 129 805 04 44 |

⇒	Test scope	Test connection	Test condition	Nominal value	Possible cause/Remedy
7.0	Leakage while pressurized	Yellow connector on tester.	Apply 600 mbar pressure to lines.	Pressure drop 0 mbar in 1 minute.	Pneumatic line leaks. Repair/replace line.

Pneumatic Test Program – Test (OSB)

E. Air cushion

Preparation for Test:

1. Provide access to connector between control valve and pneumatic lines.

⇒	Test scope	Test connection	Test condition	Nominal value	Possible cause/Remedy
8.0	Backrest air cushion and pneumatic line leakage	Yellow connector on tester.	Apply 200 mbar pressure individually to each line in the pneumatic harness.	Pressure drop 5 mbar in 1 minute.	Air cushion and pneumatic line in backrest leak, replace.