

#### Pneumatic Test Program – Component Locations (CL)

#### Model 170

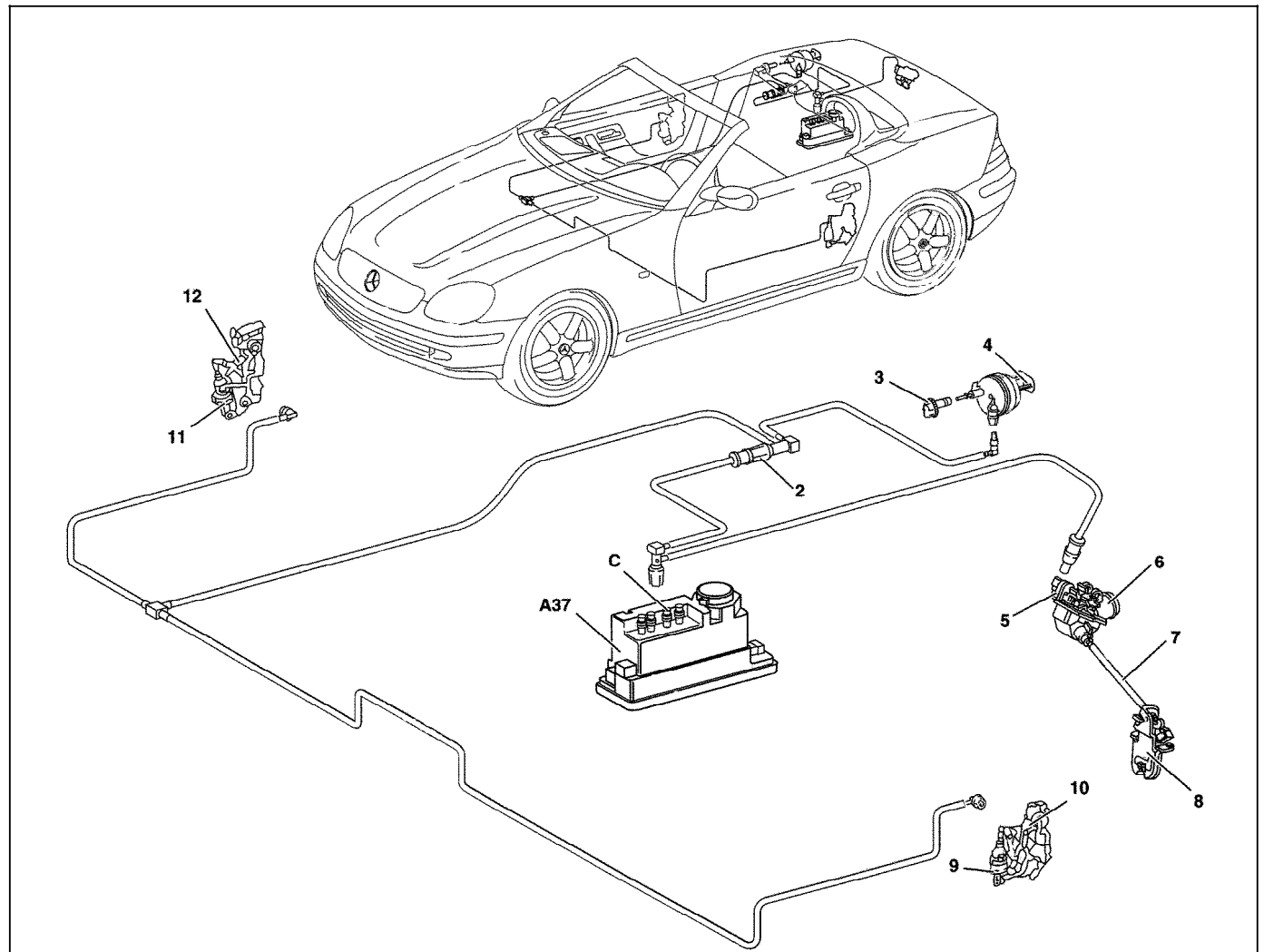

Figure 1

- A37 PSE control module, combined function
- c Pneumatic connection, CL
- 2 Pneumatic distributor, CL, frame floor
- 3 Pneumatic line, fuel tank filler flap sleeve
- 4 Pneumatic line, fuel tank filler flap actuator
- 5 Pneumatic line, trunk lid CL actuator
- 6 Locking cylinder housing
- 7 Linkage
- 8 Trunk lid lock
- 9 Left front door CL actuator
- 10 Left front door lock
- 11 Right front door CL actuator
- 12 Right front door lock

P80.20-0315-06x

Pneumatic Test Program – Component Locations (CL)

Model 210

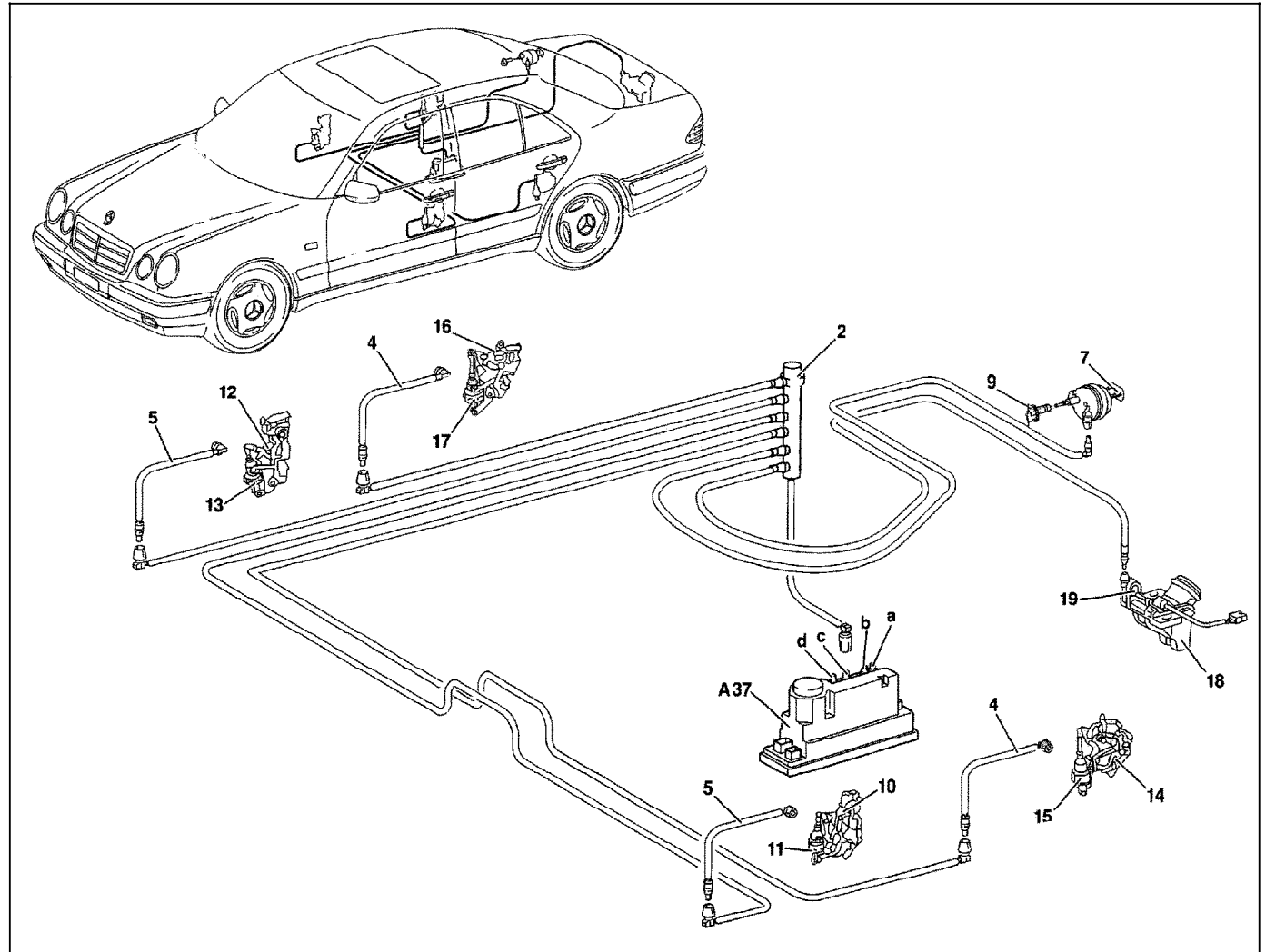

Figure 2

- A37 PSE control module, combined function
- a Pneumatic connection, OSB
- b Pneumatic connection, MVA
- c Pneumatic connection, CL/RTR
- d Pneumatic connection, RHR
- 2 Pneumatic distributor, CL
- 4 Pneumatic line, left and right rear doors
- 5 Pneumatic line, left and right front doors
- 7 Fuel tank filler flap actuator
- 9 Fuel tank filler flap sleeve
- 10 Left front door lock
- 11 Left front door CL actuator
- 12 Right front door lock
- 13 Right front door CL actuator
- 14 Left rear door lock
- 15 Left rear door CL actuator
- 16 Right rear door lock
- 17 Right rear door CL actuator
- 18 Trunk lid lock
- 19 Trunk lid CL actuator

P80-5269-06x