

#### 3.3 Manifold Vacuum Assist (PSE/MVA) Model 210

	Page
<b>Electrical Test Program</b>	
Component Locations .....	20/1
Connection of Components .....	21/1
<b>Pneumatic Test Program</b>	
Component Locations .....	31/1
Test .....	32/1

#### **Activation of the Pneumatic System Equipment (PSE):**

Working pressure of the PSE for manifold vacuum assist (MVA) is controlled entirely by the pressure switch within the PSE control module, once the combination control module (N10-1) has received the ignition ON signal via the CAN-interface or **REST ON** signal when Ignition is OFF.

Electrical Test Program – Component Locations (MVA)

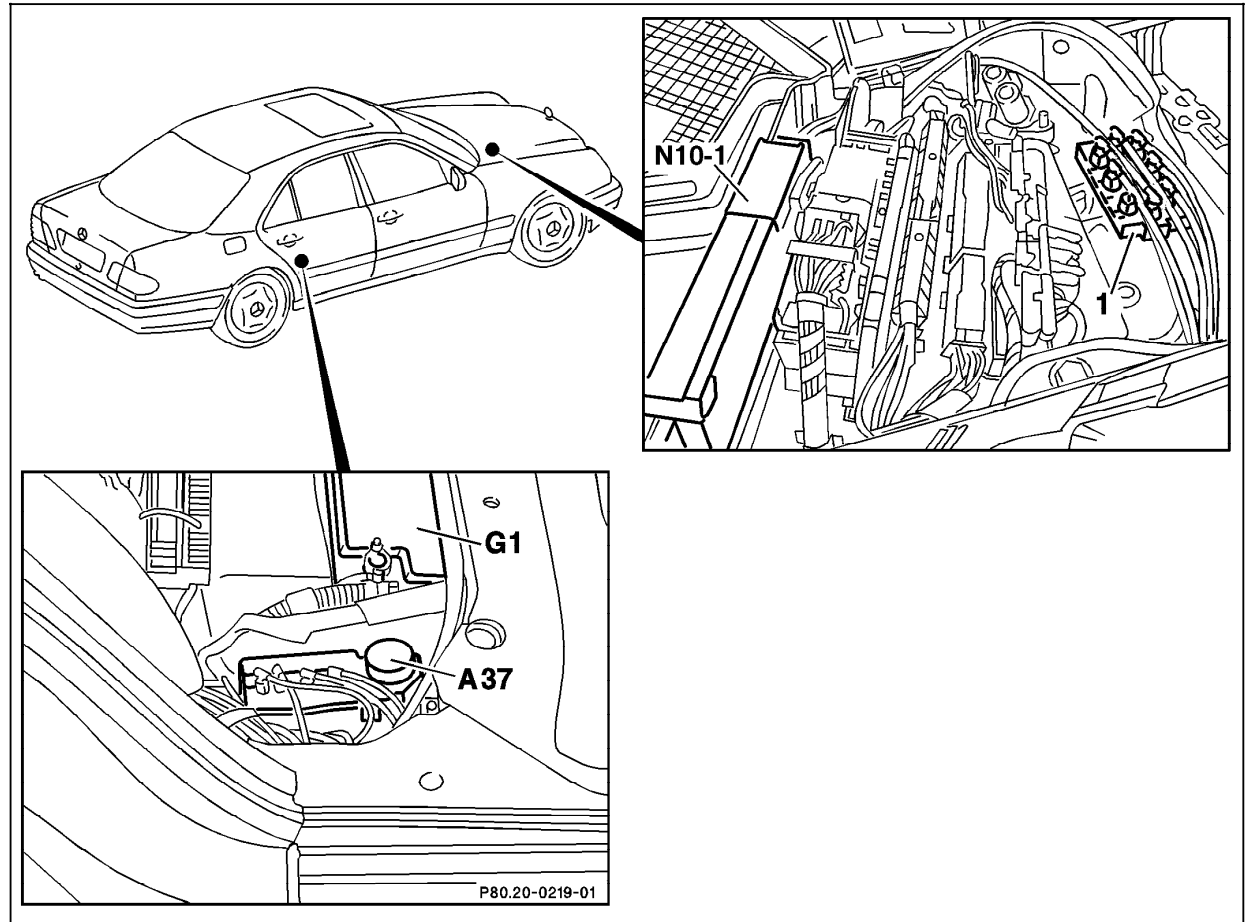

Figure 1

- A37 PSE control module, combined functions
- G1 Battery
- N10-1 Combination control module

U80.20-0224-06

#### Electrical Test Program – Connection of Components

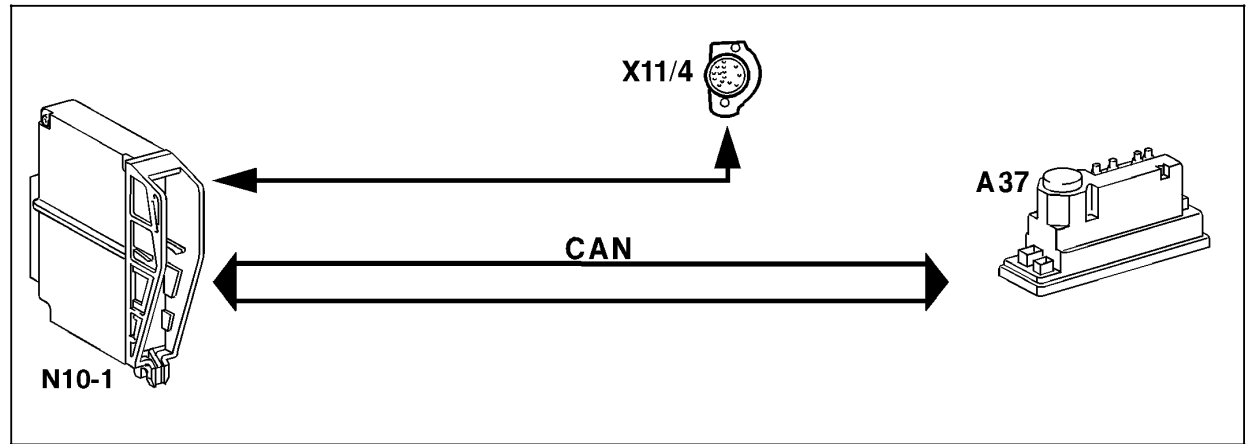

Figure 1

- A37 PSE control module, combined functions
- CAN Control-Area-Network
- N10-1 Combination control module
- X11/4 Data link connector (DTC readout)

U80.20-0235-04

#### Pneumatic Test Program – Component Locations (MVA)

#### Gasoline Vehicle Component Locations

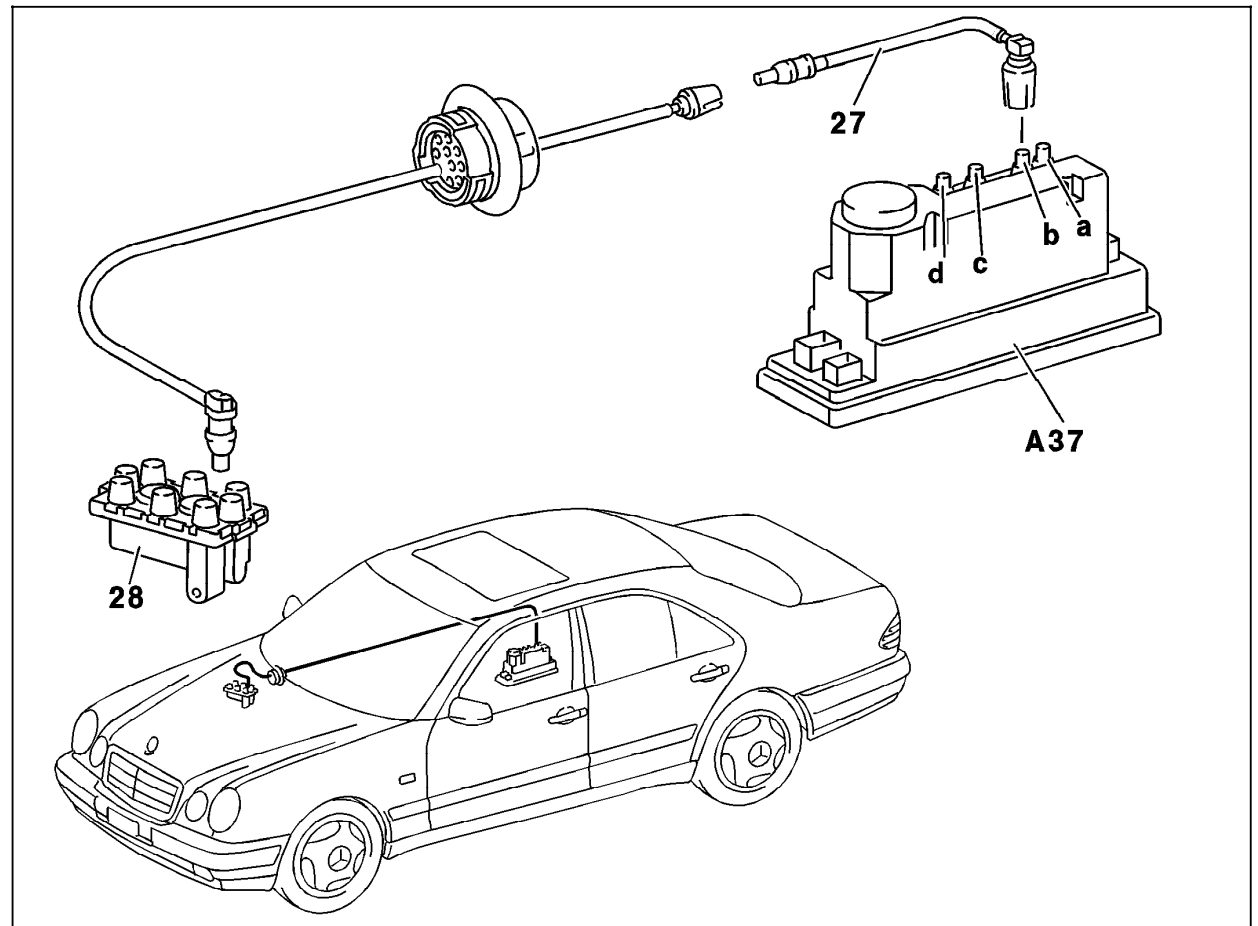

Figure 1

- A37 PSE control module, combined functions
- a Pneumatic connection OSB
- b Pneumatic connection MVA
- c Pneumatic connection CL, RTR
- d Pneumatic connection RHR
- 27 Pneumatic line, MVA (color code: transparent)
- 28 Vacuum distributor

P80.20-0217-06

#### Pneumatic Test Program – Component Locations (MVA)

##### Diesel Vehicle Component Locations

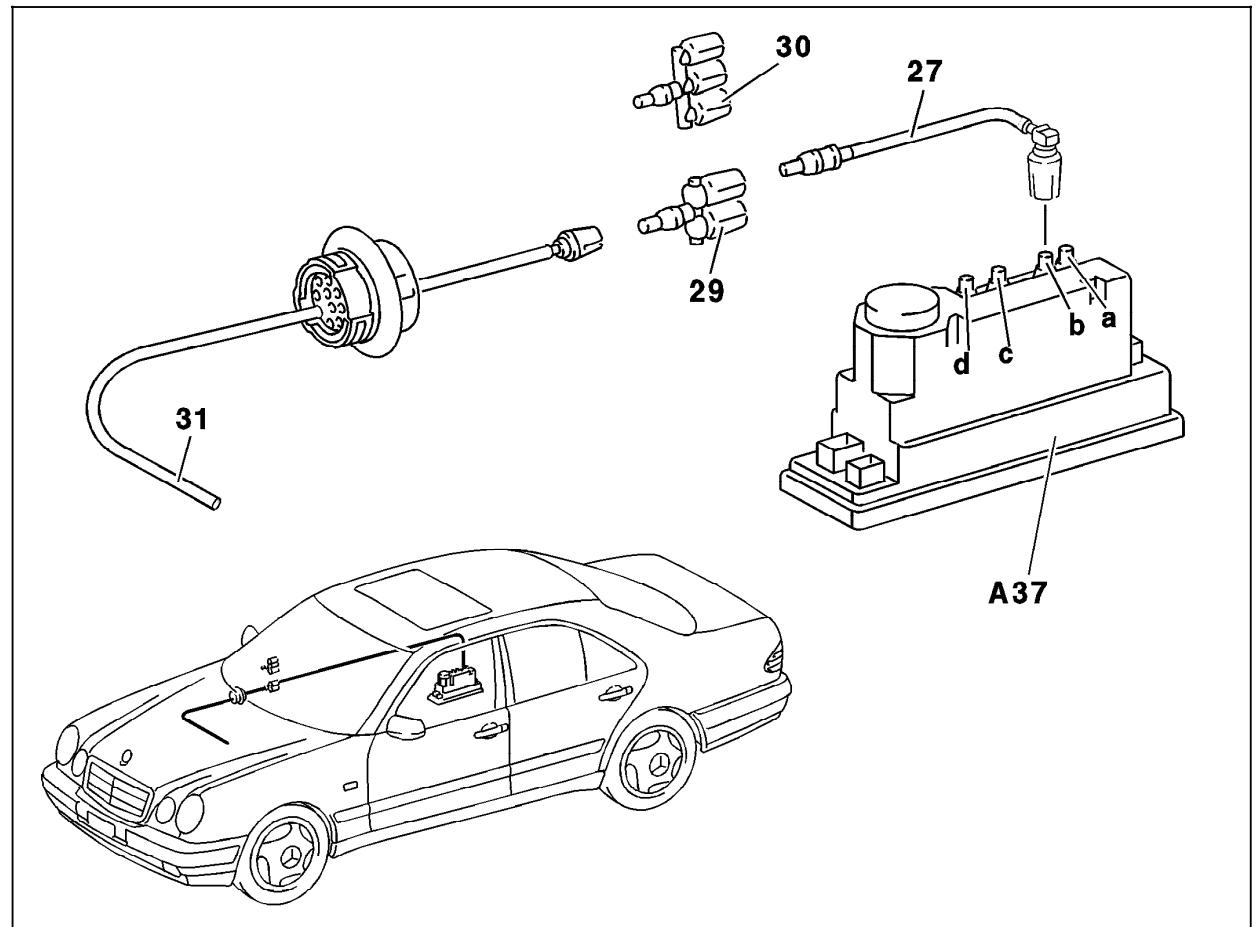

Figure 2

- A37 PSE control module, combined functions
- a Pneumatic connection OSB
- b Pneumatic connection MVA
- c Pneumatic connection CL, RTR
- d Pneumatic connection RHR
- 27 Pneumatic line, MVA (color code: transparent)
- 29/30 Vacuum distributor
- 31 Pneumatic line (connection at manifold, color code: gray)

P80.20-0216-06

#### Pneumatic Test Program – Test (MVA)

Preliminary work:

PSE control module voltage supply ..... 23 PSE ⇒ 1.0, 2.0  
 PSE Control Module Test ..... 32 PSE

#### Data (mbar)

Test procedure	Permissible deviation
Allowable leakage of pneumatic lines and vacuum distribution block <sup>1)</sup> at 300 mbar vacuum in 1 minute.	30 mbar
Allowable leakage of vacuum distribution block <sup>1)</sup> with line at 300 mbar vacuum in 1 minute.	25 mbar

<sup>1)</sup> Vacuum distribution block used with gasoline models only.

#### Special Tools

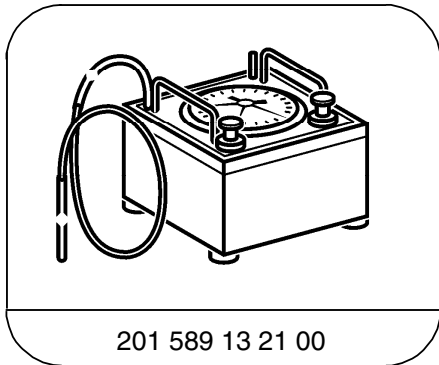

201 589 13 21 00

Tester

#### Pneumatic Test Program – Test (MVA)

##### A. Entire System

###### Preparation for Test:

1. Provide access to PSE control module (A37), disconnect **transparent** MVA pneumatic line with socket from PSE control module.
2. Connect tester to bottom side of pneumatic multiple connector at **SRU** (MVA) using connector 202 805 03 44.
2. Connect tester to disconnected pneumatic line using connector 202 805 03 44.

###### Gasoline models:

1. Provide access to vacuum distribution block in right component compartment and pry off all pneumatic lines except **transparent** MVA line at connection 1.

###### Diesel models:

4. Disconnect **gray** pneumatic line from manifold and cap using cap 000 987 11 45.
5. Provide access to vacuum distributor behind right A-pillar.
6. Disconnect **medium green** pneumatic line (automatic A/C) and **violet** pneumatic line (headlamp range adjustment).
7. Cap vacuum distributor using connector 124 805 02 44.



If no leakage is found during test of MVA, check any connected pneumatic systems for leaks as well.

###### Parts Required for Test:

1	Connector	202 805 03 44
1	Rubber hose, 50 mm long	007 997 61 82
2	Connector	124 805 02 44
1	Cap	000 987 11 45

###### Note:

The connections on the PSE control module and pneumatic multiple connector are marked with their German acronyms. In other words:  
**ZV** (German) = **CL** (English),  
**SRU** (German) = **MVA** (English),  
**OSL** (German) = **OSB** (English).

⇒	Test scope	Test connection	Test condition	Nominal value	Possible cause/Remedy
1.0	<b>Multiple connector, pneumatic line with vacuum distribution block</b> <sup>1)</sup>	<b>Black</b> connector on tester to connector.	Apply 300 mbar vacuum to entire system.	Vacuum loss 30 mbar in 1 minute.	⇒ 2.0, ⇒ 3.0

<sup>1)</sup> Vacuum distributor block on gasoline models only.

Pneumatic Test Program – Test (MVA)

B. Vacuum distributor block (gasoline models only)

Preparation for Test:

1. Provide access to vacuum distribution block.
2. Disconnect pneumatic lines at vacuum distribution block.
3. Connect tester to **white** pneumatic line (pneumatic connector # 6).

Parts Required for Test:

- |   |                         |               |
|---|-------------------------|---------------|
| 1 | Connector               | 202 805 03 44 |
| 1 | Rubber hose, 50 mm long | 007 997 61 82 |
| 1 | Pneumatic line, 1m long | 000 158 14 35 |

⇒	Test scope	Test connection	Test condition	Nominal value	Possible cause/Remedy
2.0	<b>Vacuum applied to vacuum distribution block and pneumatic line</b>	<b>Black</b> connector on tester.	Apply 300 mbar vacuum to vacuum distribution block and line.	Vacuum loss 25 mbar in 1 minute.	Vacuum distributor block leaks. Replace.



Pneumatic Test Program – Test (MVA)

C. Lines

Preparation for Test:

1. Connect tester to one end of pneumatic line and plug other end with cap, part no. 000 987 11 45.

Parts Required for Test:

- |   |                         |               |
|---|-------------------------|---------------|
| 1 | Cap                     | 000 987 11 45 |
| 1 | Rubber hose, 50 mm long | 007 997 61 82 |
| 1 | Connector               | 202 805 03 44 |



If vacuum is not available at the vacuum distribution block with the PSE control module operating correctly, check the effected lines for clogging or kinks.

⇒	Test scope	Test connection	Test condition	Nominal value	Possible cause/Remedy
3.0	<b>Vacuum leakage</b>	<b>Black</b> connector on tester.	Apply 300 mbar vacuum to vacuum distribution block.	Vacuum loss 0 mbar in 1 minute.	Pneumatic line or vacuum distribution block. Replace.