

#### Pneumatic Test Program – Test (RHR)

Preliminary work:

PSE control module voltage supply ..... 23 PSE ⇒ 1.0, 2.0  
 PSE Control Module Test ..... 32 PSE

#### Data (mbar)

Test procedure	Permissible deviation
Allowable system leakage of 300 mbar vacuum in 1 minute.	30 mbar
Allowable leakage of actuators with line at 300 mbar vacuum in 1 minute.	25 mbar

Vacuum distribution block used with gasoline models only

#### Special Tools

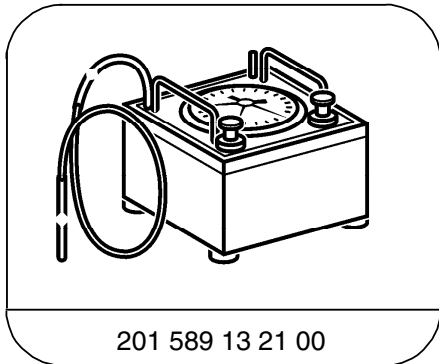

201 589 13 21 00

Tester

#### Pneumatic Test Program – Test (RHR)

#### A. Entire System

##### Preparation for Test:

1. Provide access to PSE control module (A37), disconnect **white** RHR pneumatic line with socket from PSE control module.
2. Connect tester to disconnected socket using connector 202 805 03 44.



If an actuator does not operate correctly and no leakage is found, check the respective lines for kinks or blockages.

##### Parts Required for Test:

1	Connector	202 805 03 44
2	Rubber hose, 50 mm long	007 997 61 82
1	Pneumatic line, 1 m long	000 158 14 35

##### Note:

The connections on the PSE control module and pneumatic multiple connector are marked with their German acronyms. In other words:  
**ZV** (German) = **CL** (English),  
**SRU** (German) = **MVA** (English),  
**OSL** (German) = **OSB** (English).

⇒	Test scope	Test connection	Test condition	Nominal value	Possible cause/Remedy
1.0	<b>Complete system evacuated</b>	<b>Black</b> connector on tester to connector	Apply 300 mbar vacuum to entire system.	Vacuum loss 30 mbar in 1 minute.	⇒ 2.0, ⇒ 3.0

#### Pneumatic Test Program – Test (RHR)

#### B. Actuators

##### Preparation for Test:

1. Remove RHR actuators.
2. Connect tester to pneumatic connection of actuator.

##### Parts Required for Test:

- |   |                         |               |
|---|-------------------------|---------------|
| 2 | Rubber hose, 50 mm long | 007 997 61 82 |
| 1 | Pneumatic line, 1m long | 000 158 14 35 |
| 1 | Socket                  | 202 800 02 53 |

⇒	Test scope	Test connection	Test condition	Nominal value	Possible cause/Remedy
2.0	<b>Actuator hold vacuum</b>	<b>Black</b> connector on tester.	Apply 300 mbar vacuum to actuator.	Vacuum loss 25 mbar in 1 minute.	Actuator leaks. Replace.

#### Pneumatic Test Program – Test (RHR)

#### C. Lines

##### Preparation for Test:

1. Connect tester to one end of pneumatic line and plug other end with cap, part no. 124 805 02 44.

##### Parts Required for Test:

1	Connector	202 805 03 44
3	Cap	124 805 02 44
1	Connector, 50 mm long	007 997 61 82

⇒	Test scope	Test connection	Test condition	Nominal value	Possible cause/Remedy
3.0	<b>Vacuum leakage</b>	<b>Black</b> connector on tester.	Apply 300 mbar vacuum to pneumatic line.	Vacuum loss 0 mbar in 1 minute.	Pneumatic line leaks. Replace.