

Electrical Test Program – Component Locations (RHR)

Models 202, 208  
(model 202 shown)  
(for balance of compnents see Figure 2)

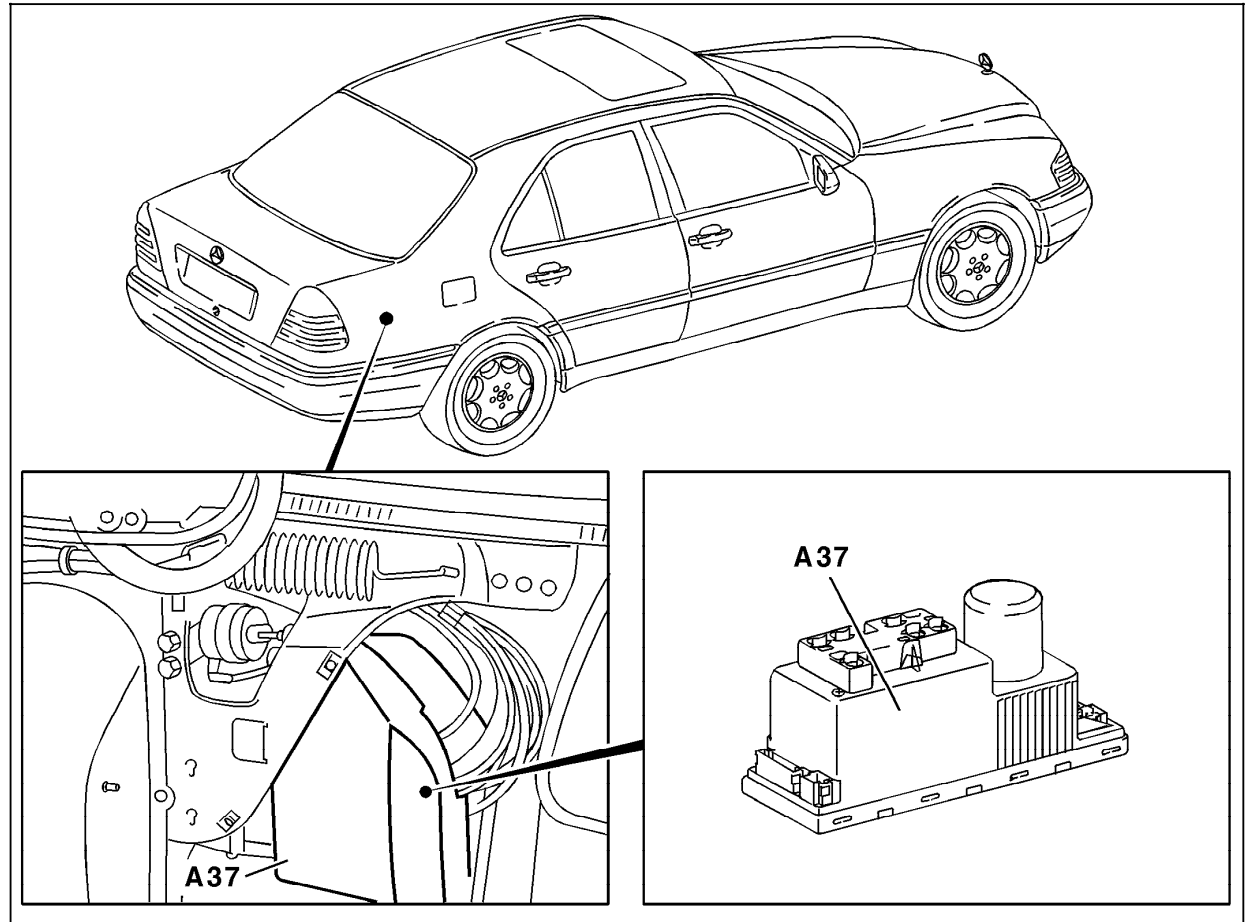

Figure 1

A37 PSE control module, combined functions

P80.20-0365-06

Electrical Test Program – Component Locations (RHR)

Model 210 sedan

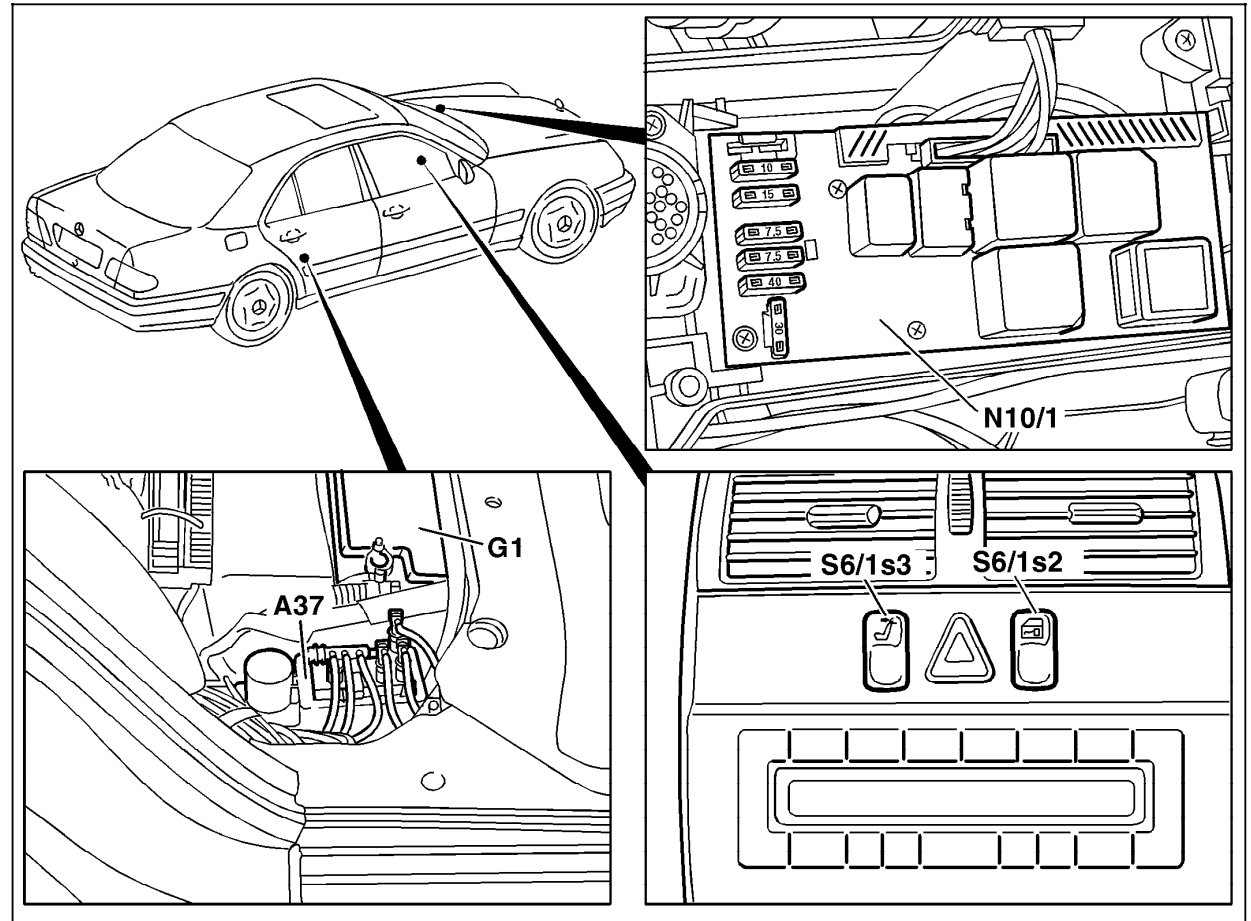

Figure 2

- A37 PSE control module, combined functions
- G1 Battery
- N10/1 Signal pick-up and activation module (SAM) left front
- S6/1s2 Interior switch (CL)
- S6/1s3 RHR unlocking switch

P80.20-0371-06