

Pneumatic Test Program – Component Locations (OSB)

Model 129

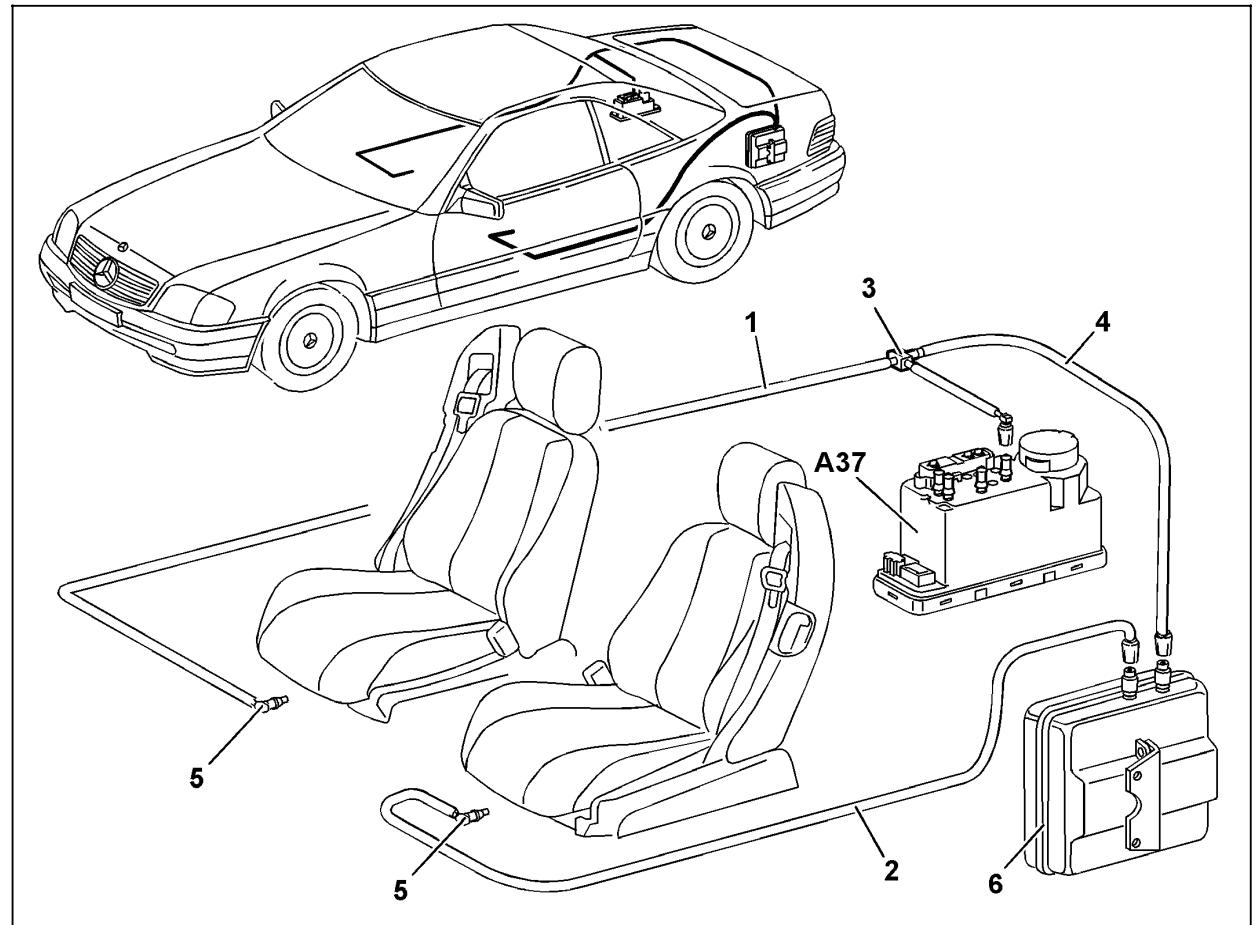

Figure 1

- A37 PSE control module, combined functions
- 1 Pneumatic line, OSB, passenger-side
- 2 Pneumatic line, OSB, driver's side
- 3 Pneumatic line, T-connector, OSB
- 4 Pneumatic line, vacuum reservoir
- 5 Pneumatic connector, seat
- 6 Vacuum reservoir

P80.20-0431-06

Pneumatic Test Program – Component Locations (OSB)

Model 140

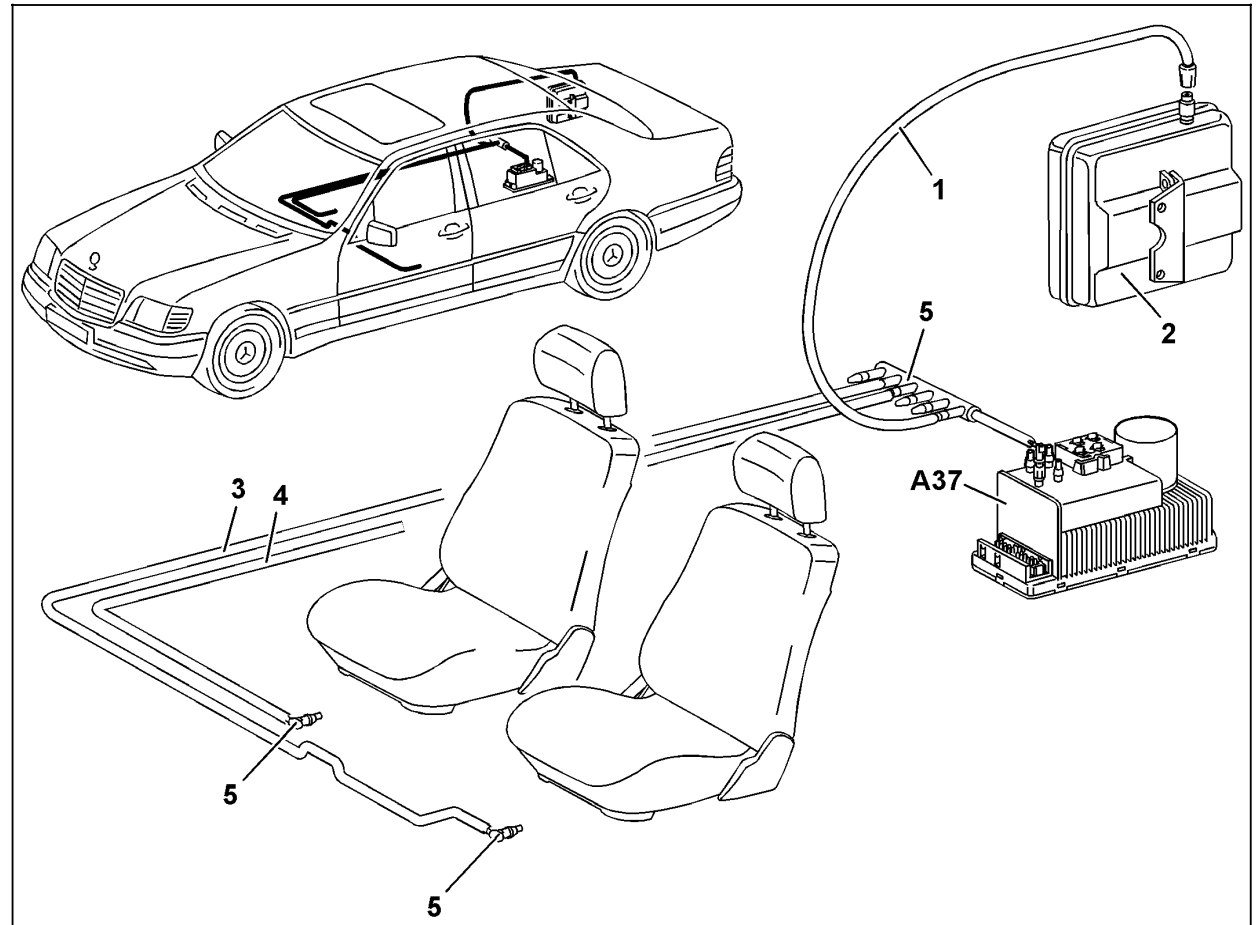

Figure 1

- A37 PSE control module, combined functions
- 1 Pneumatic line, vacuum reservoir
- 2 Vacuum reservoir
- 3 Pneumatic line, OSB, driver's seat
- 4 Pneumatic line, OSB, passenger-side seat
- 5 Pneumatic connector, seat

P80.20-0432-06