

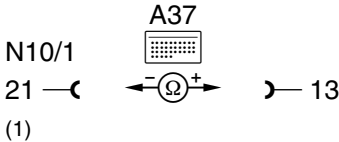

Electrical Test Program – Test

⇒		Test scope	Test connection	Test condition	Nominal value	Possible cause/Remedy
1.0		RHR unlocking circuit		Rear head restraints extended. Ignition: ON RHR unlocking switch (S52): Press switch:	Rear head restraints retract.	Wiring, (A37), ⇒ 1.1, 23 PSE/CL ⇒ 8.0, 32 PSE/RHR ⇒ 1.0, 32 PSE ⇒ 8.0
1.1		RHR release switch (S52)	 <p>N10/1 21 —()— A37 (1) ← Ω → 13</p>	Disconnect A37 from  S52: Rest position Hold pressed	>20 kΩ < 40 Ω	Wiring, S52