

Pneumatic Test Program – Component Locations (RTR)

Model 129

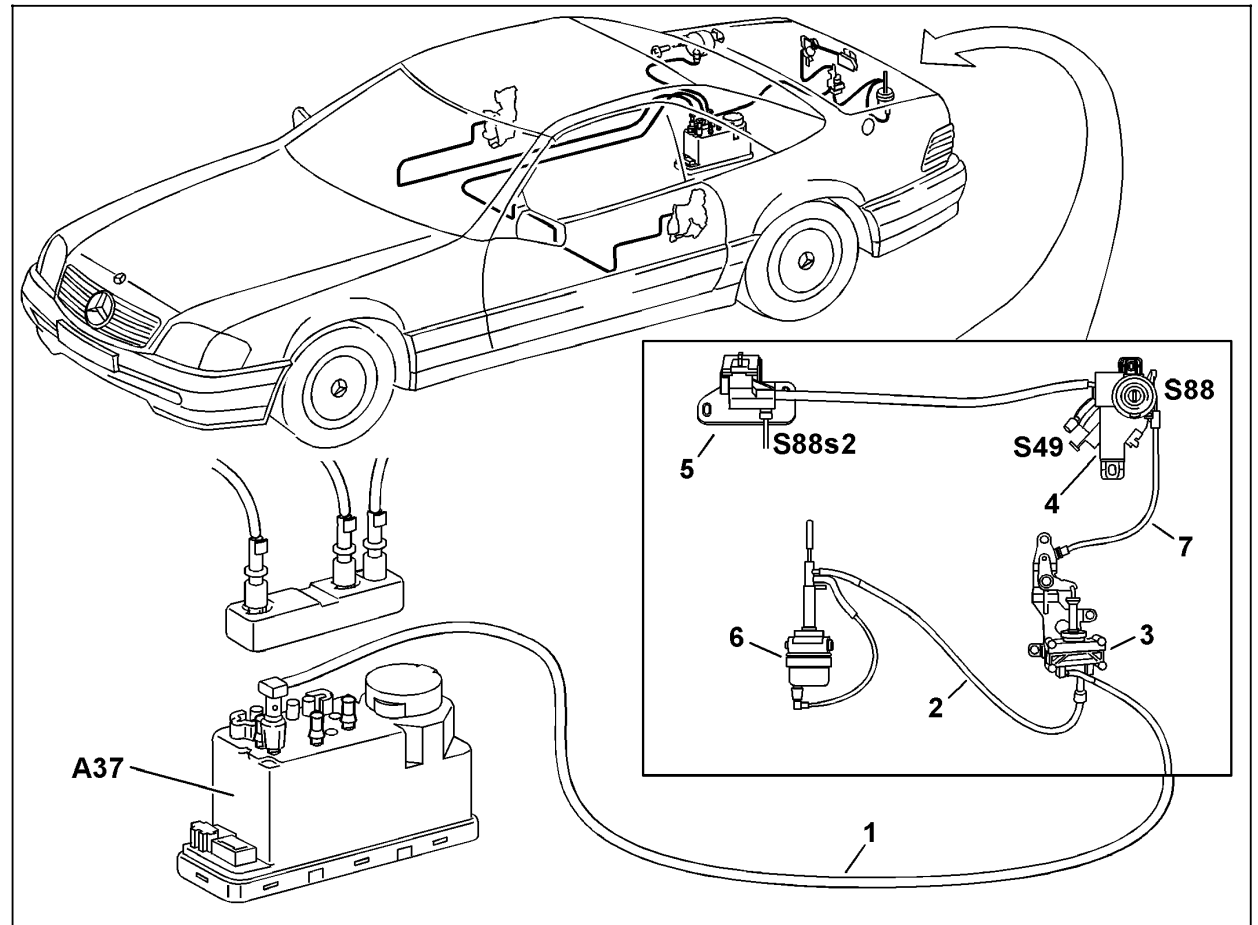

Figure 1

- A37 PSE control module, combined functions
- 1 Pneumatic line, RTR
- 2 Pneumatic line, actuator/trunk lid riser
- 3 Actuator, RTR
- 4 Trunk lid lock
- 5 Trunk lid locking
- 6 Trunk lid riser
- 7 Bowden cable

P80.20-0423-06

Pneumatic Test Program – Component Locations (RTR)

Model 140

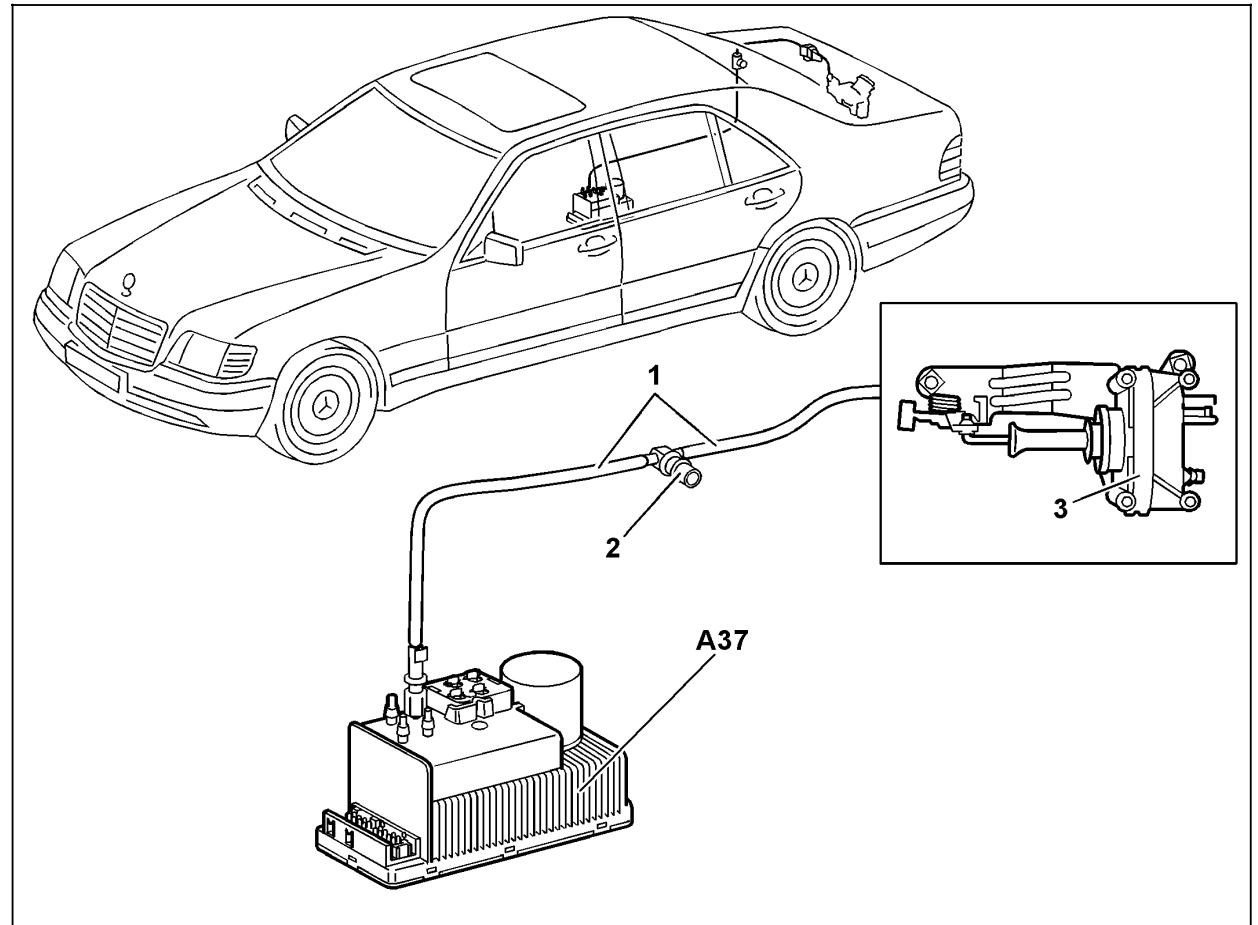

Figure 2

- A37 PSE control module, combined functions
- 1 Pneumatic line, RTR
- 2 T-connector, RTR/RHR
- 3 Actuator, RTR

P80.20-0424-06