

Electrical Test Program – Component Locations

Xenon Headlamps

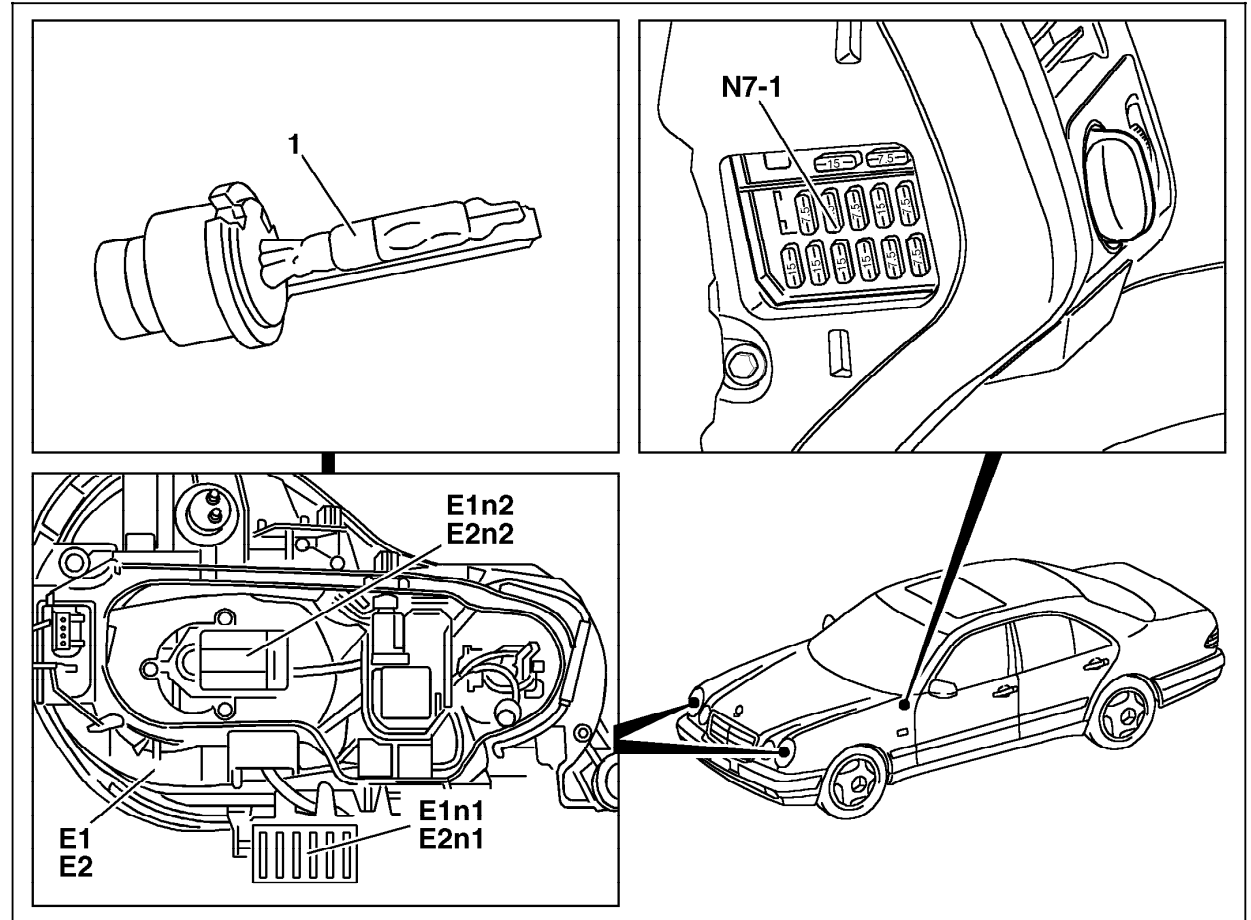

Figure 1

- 1 Xenon headlamp (D2R, 35W)
- E1 Left headlamp unit
- E1n1 Xenon headlamp control module
- E1n2 Xenon headlamp ignition module
- E2 Right headlamp unit
- E2n1 Xenon headlamp control module
- E2n2 Xenon headlamp ignition module
- N7-1 Illumination control module

P82.10-0292-06

Electrical Test Program – Component Locations

Xenon Headlamps

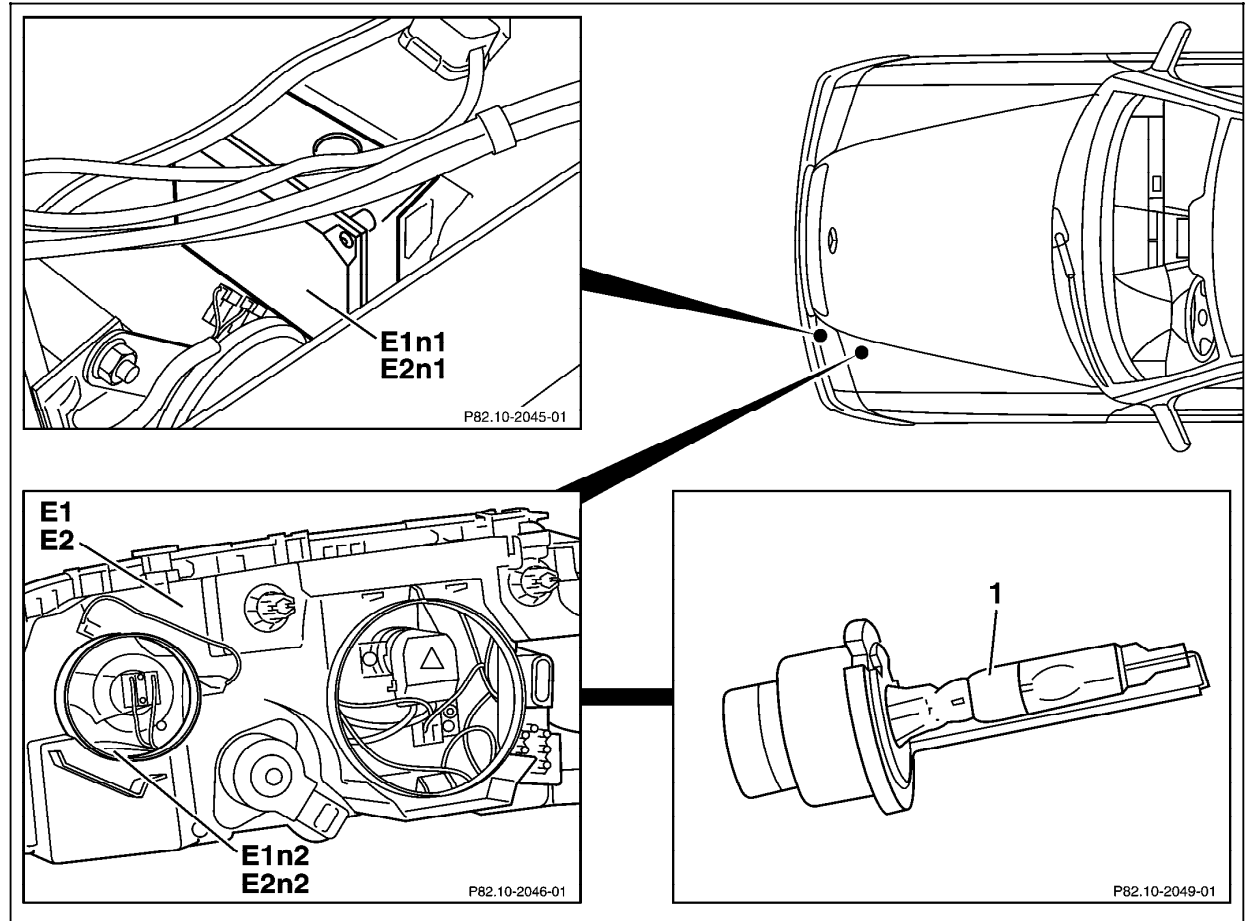

Figure 2

- 1 Xenon headlamp (D2R, 35W)
- E1 Left headlamp unit
- E1n1 Xenon headlamp control module
- E1n2 Xenon headlamp ignition module
- E2 Right headlamp unit
- E2n1 Xenon headlamp control module
- E2n2 Xenon headlamp ignition module

P82.10-2044-06