

Electrical Test Program – Preparation for Test

Preliminary work:  
Diagnosis - Diagnostic Trouble Code (DTC) Memory ..... 12

Preparation for Test:

- 1. Fuses OK.
- 2. Battery voltage >11 V.
- 3. Install model specific HHT module into HHT.

- 4. Connect Hand-Held Tester (HHT ) according to connection diagram shown in section 0.

Electrical wiring diagrams :  
Electrical Troubleshooting Manual, Model 210, Volume 2, group 80.

Special Tools

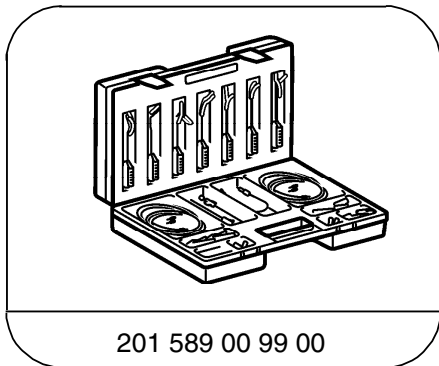

201 589 00 99 00

Electrical connecting set

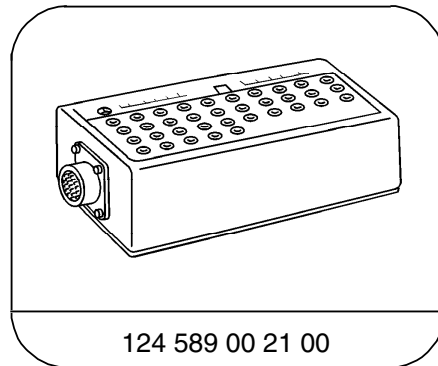

124 589 00 21 00

35-pin socket box

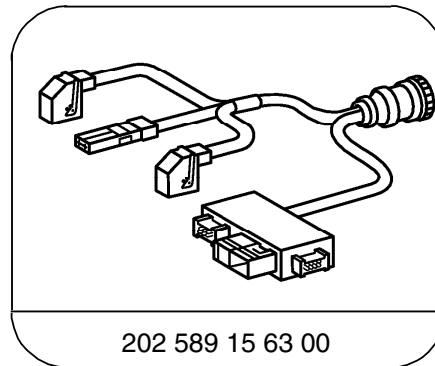

202 589 15 63 00

18-pin and 12-pin CAN test cable

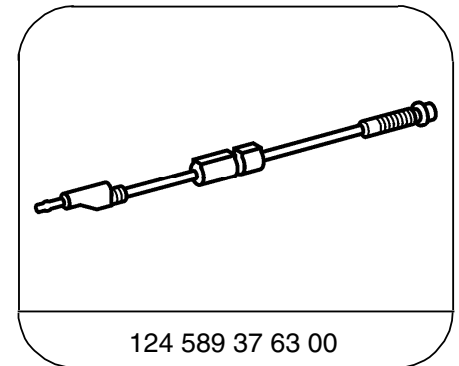

124 589 37 63 00

Fused cable

## 4.7 Infrared Remote Central Locking (RCL)

Model 210.072 up to 06/96

### Special Tools

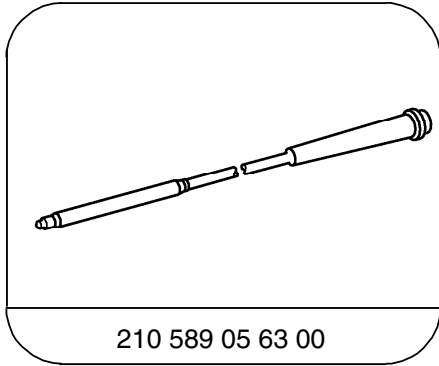

210 589 05 63 00

Adapter cable

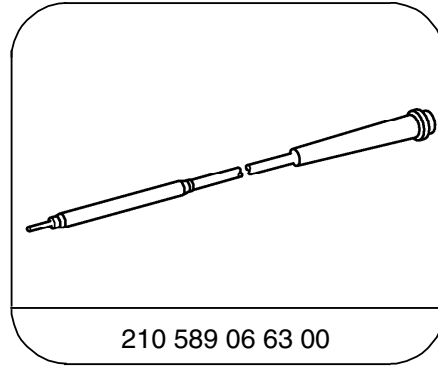

210 589 06 63 00

Adapter cable

### Conventional tools, test equipment

Description	Brand, model, etc.
Multimeter <sup>1)</sup>	Fluke models 23, 83, 85, 87

<sup>1)</sup> Available through the MBUSA Standard Equipment Program.

## Electrical Test Program – Test

### Connection Diagram - Socket Box

**Note:**

- Model 210: IR DAS control module located behind instrument cluster.
- Using the Hand-Held tester (HHT), erase DTC'S for SRS Airbag after installation of instrument cluster and steering wheel.

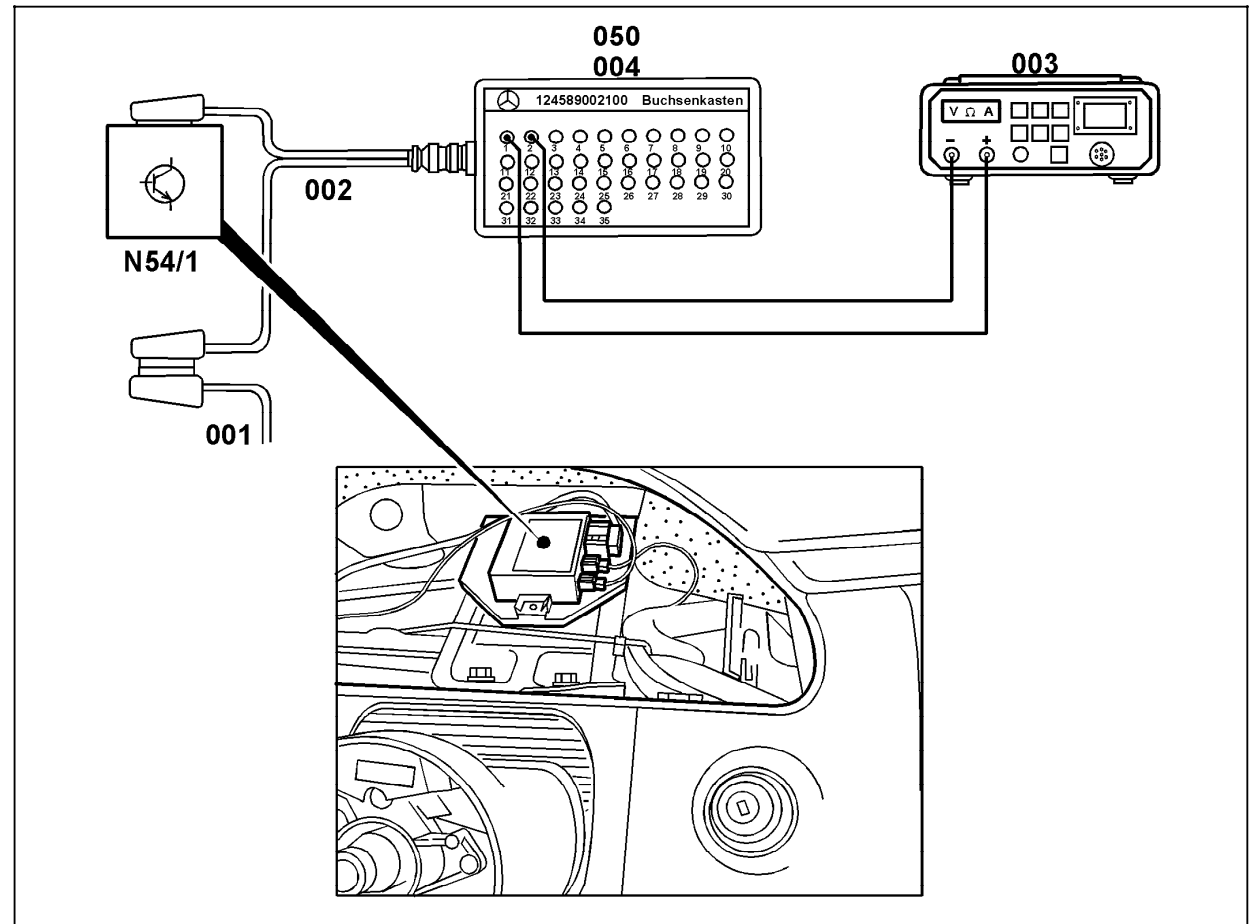

Figure 1

- |         |                                 |
|---------|---------------------------------|
| 001     | IR DAS control module connector |
| 002     | Test cable                      |
| 003     | Multimeter                      |
| 004/050 | Socket box (35-pole)            |
| N54/1   | IR DAS control module           |

P80.30-0291-06