

Electrical Test Program – Test

CAUTION!

Injury hazard from pinching and crushing, in extreme cases extremities can even be severed when caught in the mechanism.

Do not allow any body parts to be in the general area of the moving components.

Preparation for Test:



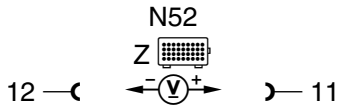
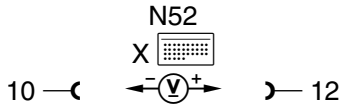
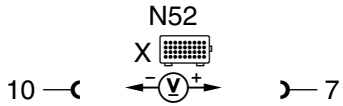

1. Review entire 11.2 section.

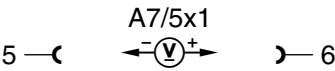
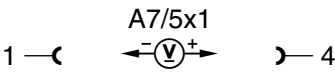
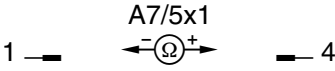
⇒		Test scope	Test connection	Test condition	Nominal value	Possible cause/Remedy
1.0		Voltage supply Circuit 30			11 – 14 V	Wiring.
2.0		Voltage supply Circuit 15, 31		Ignition: ON	11 – 14 V	Wiring.
3.0		Hydraulic unit (A7/5) Hydraulic unit motor (A7/5m1) control signal		Ignition: ON Operate power soft switch towards open or close .	0 – 1 V 11 – 14 V Hydraulic unit runs.	23⇒ 23.0 Power soft top control module (N52) 23⇒ 23.0 Power soft top switch (S84) (N52) ⇒ 3.2 Hydraulic unit motor (A7/5m1) ⇒ 3.3 Hydraulic unit relay (A7/5k1) ⇒ 3.1



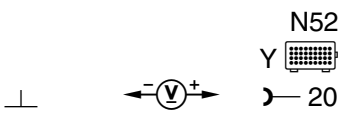

Electrical Test Program – Test

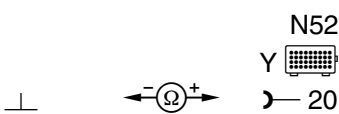
⇒		Test scope	Test connection	Test condition	Nominal value	Possible cause/Remedy
3.1		Hydraulic unit relay (A7/5k1) Activation		Ignition: OFF Unplug connector A7/5x1 Ignition: ON Move power soft top switch (S84) toward Open or Close .	0 – 1 V 11 – 14 V	Wiring, Power soft top switch (S84), Power soft top control module (N52). Wiring.
3.2		Hydraulic unit motor (A7/5m1) Voltage supply		Unplug connector A7/5x1.	11 – 14 V	Wiring.
3.3		Hydraulic unit motor (A7/5m1)		Unplug connector A7/5x1, Remove relay A7/5k1, Bridge sockets 1 and 3 of relay connector A7/5k1	0.1 – 1.5 Ω	A7/5m1, See SMS, Job No. 77-350

Electrical Test Program – Test

⇒		Test scope	Test connection	Test condition	Nominal value	Possible cause/Remedy
4.0		Left cover “Locked” switch (A24s2)		Power soft top control module in diagnostic mode, see 22. Soft top compartment cover: locked: unlocked:	 0 – 1 V 11 – 14 V	Wiring, (A24s2), ⇒ 4.1, See SMS, Job no. 77-440, Wiring, (A24s2), ⇒ 4.1, N52
4.1		Left cover “Locked” switch (A24s2)		Ignition: OFF Disconnect test cable from N52, Soft top compartment cover: locked: unlocked:	 0 – 5 Ω >20 kΩ	 Wiring, (A24s2) Wiring, (A24s2)

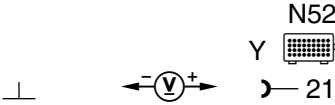
Electrical Test Program – Test

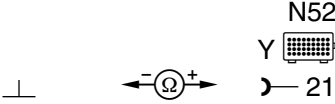
⇒		Test scope	Test connection	Test condition	Nominal value	Possible cause/Remedy
5.0		Right cover "Locked" switch (A25s2)		Power soft top control module in diagnostic mode, see 22. Soft top compartment cover: <p style="text-align: right;">locked: 0 – 1 V</p> <p style="text-align: right;">unlocked: 11 – 14 V</p>		Wiring, (A25s2), ⇒ 5.1, See SMS, Job no. 77-440, Wiring, (A25s2), ⇒ 5.1, N52
5.1		Right cover "Locked" switch (A25s2)		Ignition: OFF Disconnect test cable from N52 Soft top compartment cover: <p style="text-align: right;">locked: 0 – 5 Ω</p> <p style="text-align: right;">unlocked: >20 kΩ</p>		Wiring, (A25s2) Wiring, (A25s2)



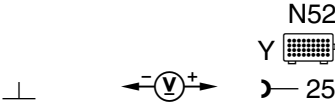
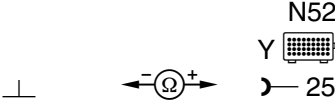

Electrical Test Program – Test

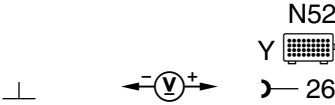
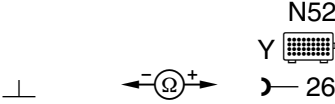
⇒		Test scope	Test connection	Test condition	Nominal value	Possible cause/Remedy
6.0	4	Left cover "Closed" switch (A24s1)		Power soft top control module in diagnostic mode, see 22. Soft top compartment cover: <p style="text-align: right;">closed:</p> <p style="text-align: right;">raised:</p>	<p style="text-align: right;">0 – 1 V</p> <p style="text-align: right;">11 – 14 V</p>	Wiring, (A24s1), ⇒ 6.1, See SMS, Job no. 77-440 Wiring, (A24s1), ⇒ 6.1, N52
6.1	4	Left cover "Closed" switch (A24s1)		Ignition: OFF Disconnect test cable from N52 Soft top compartment cover: <p style="text-align: right;">closed:</p> <p style="text-align: right;">raised:</p>	<p style="text-align: right;">0 – 5 Ω</p> <p style="text-align: right;">>20 kΩ</p>	Wiring, (A24s1) Wiring, (A24s1)

Electrical Test Program – Test

⇒		Test scope	Test connection	Test condition	Nominal value	Possible cause/Remedy
7.0	5	Right cover "Closed" switch (A25s1)		Power soft top control module in diagnostic mode, see 22. Soft top compartment cover: closed: raised:	0 – 1 V 11 – 14 V	Wiring, (A25s1), ⇒ 7.1 See SMS, Job No. 77-440 Wiring, (A25s1), ⇒ 7.1, N52
7.1	5	Right cover "Closed" switch (A25s1)		Ignition: OFF Disconnect test cable from N52 Soft top compartment cover: closed: raised:	0 – 5 Ω >20 kΩ	Wiring, (A25s1) Wiring, (A25s1)

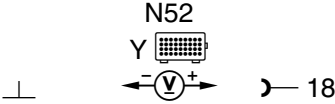

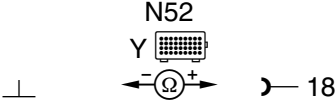

Electrical Test Program – Test

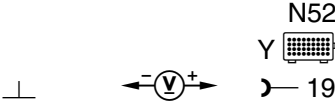
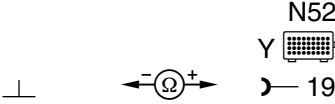
⇒		Test scope	Test connection	Test condition	Nominal value	Possible cause/Remedy
8.0		Left bow "Locked" switch (A22s2)		Power soft top control module in diagnostic mode, see 22. Fabric bow: <p style="text-align: right;">locked:</p> <p style="text-align: right;">unlocked:</p>	<p style="text-align: right;">0 – 1 V</p> <p style="text-align: right;">11 – 14 V</p>	Wiring, (A22s2), ⇒ 8.1 See SMS, Job no. 77-445 Wiring, (A22s2), ⇒ 8.1, N52
8.1		Left bow "Locked" switch (A22s2)		Ignition: OFF Disconnect test cable from N52 Fabric bow: <p style="text-align: right;">locked:</p> <p style="text-align: right;">unlocked:</p>	<p style="text-align: right;">0 – 5 Ω</p> <p style="text-align: right;">>20 kΩ</p>	Wiring, (A22s2) Wiring, (A22s2)

Electrical Test Program – Test

⇒		Test scope	Test connection	Test condition	Nominal value	Possible cause/Remedy
9.0	7	Right bow "Locked" switch (A23s2)		Power soft top control module in diagnostic mode, see 22. Fabric bow: <p style="text-align: right;">locked: 0 – 1 V</p> <p style="text-align: right;">unlocked: 11 – 14 V</p>	<p style="text-align: right;">locked: 0 – 1 V</p> <p style="text-align: right;">unlocked: 11 – 14 V</p>	Wiring, (A23s2), ⇒ 9.1 See SMS, Job no. 77-445 Wiring, (A23s2) ⇒ 9.1, N52
9.1	7	Right bow "Locked" switch (A23s2)		Ignition: OFF Disconnect test cable from N52 fabric bow: <p style="text-align: right;">locked: 0 – 5 Ω</p> <p style="text-align: right;">unlocked: >20 kΩ</p>	<p style="text-align: right;">locked: 0 – 5 Ω</p> <p style="text-align: right;">unlocked: >20 kΩ</p>	Wiring, (A23s2) Wiring, (A23s2)

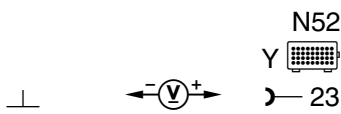

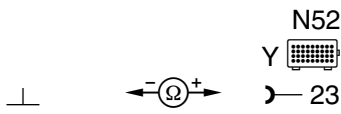
Electrical Test Program – Test

⇒		Test scope	Test connection	Test condition	Nominal value	Possible cause/Remedy
10.0		Left bow "Closed" switch (A22s1)		Power soft top control module in diagnostic mode, see 22. Fabric bow:	closed: 0 – 1 V raised: 11 – 14 V	Wiring, (A22s1), ⇒ 10.1 See SMS, Job no. 77-445 Wiring, (A22s1) ⇒ 10.1, N52
10.1		Left bow "Closed" switch (A22s1)		Ignition: OFF Disconnect test cable from N52 Fabric bow:	closed: 0 – 5 Ω raised: >20 kΩ	Wiring, (A22s1) Wiring, (A22s1), A/c pushbutton control module (N22).



11.2 Roadster Soft Top (RST), Roll Bar (RB) (Manual Deployment)

Model 129

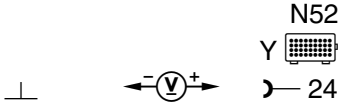
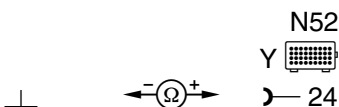
Electrical Test Program – Test

⇒		Test scope	Test connection	Test condition	Nominal value	Possible cause/Remedy
11.0		Right bow "Closed" switch (A23s1)		Power soft top control module in diagnostic mode, see 22. Fabric bow: closed: raised:	 closed: 0 – 1 V raised: 11 – 14 V	Wiring, (A23s1), ⇒ 11.1 See SMS, Job no. 77-445 Wiring, (A23s1), ⇒ 11.1 N52
11.1		Right bow "Closed" switch (A23s1)		Ignition: OFF Disconnect test cable from N52 Fabric bow: closed: raised:	 closed: 0 – 5 Ω raised: >20 kΩ	Wiring, (A23s1) Wiring, (A23s1)

Electrical Test Program – Test

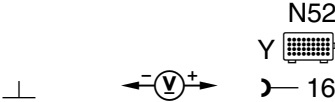
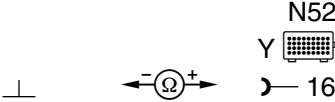
⇒		Test scope	Test connection	Test condition	Nominal value	Possible cause/Remedy
12.0		Left front soft top "Locked" switch (S84/1)		Power soft top control module in diagnostic mode, see 22. Soft top: Locked in front: Unlocked in front:	0 – 1 V 11 – 14 V	Wiring, (S84/1), ⇒ 12.1 See SMS, Job no. 77-330 Wiring, (S84/1), ⇒ 12.1 N52
12.1		Left front soft top "Locked" switch (S84/1)		Ignition: OFF Disconnect test cable from N52 Soft top: Locked in front: Unlocked in front:	0 – 5 Ω >20 kΩ	Wiring, S84/3 (SMS, Job no. 77-425). Wiring, (S84/1) Wiring, (S84/1)



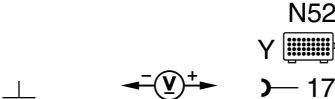
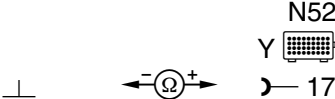

11.2 Roadster Soft Top (RST), Roll Bar (RB) (Manual Deployment)

Model 129



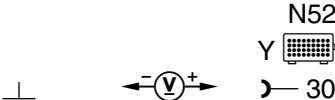

Electrical Test Program – Test

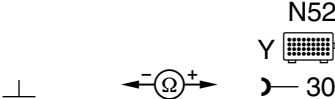
⇒		Test scope	Test connection	Test condition	Nominal value	Possible cause/Remedy
13.0	II	Right front soft top "Locked" switch (S84/2)		Power soft top control module in diagnostic mode, see 22. Soft top: Locked in front: Unlocked in front:	0 – 1 V 11 – 14 V	Wiring, (S84/2), ⇒ 13.1 See SMS, Job no. 77-330 Wiring, (S84/2), ⇒ 13.1 N52
13.1		Right front soft top "Locked" switch (S84/2)		Ignition: OFF Disconnect test cable from N52 Soft top: Locked in front: Unlocked in front:	0 – 5 Ω >20 kΩ	Wiring, (S84/2) Wiring, (S84/2)

Electrical Test Program – Test

⇒		Test scope	Test connection	Test condition	Nominal value	Possible cause/Remedy
14.0		Soft top compartment "Open" switch (S84/5)		Power soft top control module in diagnostic mode, see 22. Soft top compartment cover: <p style="text-align: right;">open: 0 – 1 V</p> <p style="text-align: right;">closed: 11 – 14 V</p>	<p style="text-align: right;">0 – 1 V</p> <p style="text-align: right;">11 – 14 V</p>	Wiring, (S84/5), ⇒ 14.1 See SMS, Job no. 77-405 Wiring, (S84/5), ⇒ 14.1 N52
14.1		Soft top compartment "Open" switch (S84/5)		Ignition: OFF Disconnect test cable from N52 Soft top compartment cover: <p style="text-align: right;">open: 0 – 5 Ω</p> <p style="text-align: right;">closed: >20 kΩ</p>	<p style="text-align: right;">0 – 5 Ω</p> <p style="text-align: right;">>20 kΩ</p>	Wiring, (S84/5) Wiring, (S84/5)

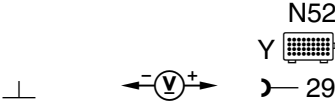
Electrical Test Program – Test

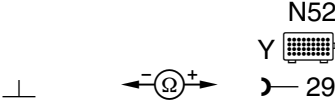
⇒		Test scope	Test connection	Test condition	Nominal value	Possible cause/Remedy
15.0		Soft top fabric bow "Raised" switch (S84/6) (fabric bow raised)		Power soft top control module in diagnostic mode, see 22. Fabric bow: <p style="text-align: right;">raised: 0 – 1 V</p> <p style="text-align: right;">lowered: 11 – 14 V</p>	<p style="text-align: right;">raised: 0 – 1 V</p> <p style="text-align: right;">lowered: 11 – 14 V</p>	Wiring, (S84/6), ⇒ 15.1 See SMS, Job no. 77-435 Wiring, (S84/6), ⇒ 15.1 N52
15.1		Soft top fabric bow "Raised" switch (S84/6) (fabric bow raised)		Ignition: OFF Disconnect test cable from N52. Fabric bow: <p style="text-align: right;">raised: 0 – 5 Ω</p> <p style="text-align: right;">lowered: >20 kΩ</p>	<p style="text-align: right;">raised: 0 – 5 Ω</p> <p style="text-align: right;">lowered: >20 kΩ</p>	Wiring, (S84/6) Wiring, (S84/6)



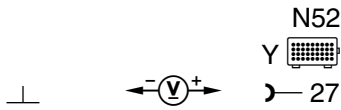
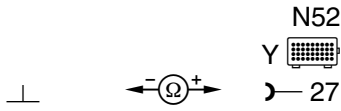

Electrical Test Program – Test

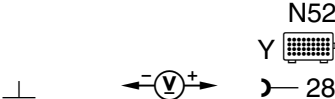
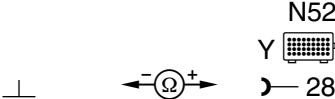
⇒		Test scope	Test connection	Test condition	Nominal value	Possible cause/Remedy
16.0	14	Soft top "Open" switch (S84/3) (soft top in storage compartment)		Power soft top control module in diagnostic mode, see 22. Soft top: in soft top compartment:	0 – 1 V up: 11 – 14 V	Wiring, (S84/3), ⇒ 16.1 See SMS, Job no. 77-425 Wiring, (S84/3), ⇒ 16.1 N52
16.1	14	Soft top "Open" switch (S84/3) (soft top in storage compartment)		Ignition: OFF Disconnect test cable from N52. Soft top: in soft top compartment:	0 – 5 Ω up: >20 kΩ	Wiring, (S84/3) Wiring, (S84/3)

Electrical Test Program – Test

⇒		Test scope	Test connection	Test condition	Nominal value	Possible cause/Remedy
17.0	IS	Soft top "Raised" switch (S84/4)		Power soft top control module in diagnostic mode, see 22. Soft top: <p style="text-align: right;">up:</p> <p>in soft top compartment:</p>	<p style="text-align: right;">up:</p> <p style="text-align: right;">in soft top compartment:</p>	Wiring, (S84/4), ⇒ 17.1 See SMS, Job no. 77-415 Wiring, (S84/3), ⇒ 17.1 N52
17.1	IS	Soft top "Raised" switch (S84/4)		Ignition: OFF Disconnect test cable from N52. Soft top: <p style="text-align: right;">up:</p> <p>in soft top compartment:</p>	<p style="text-align: right;">up:</p> <p style="text-align: right;">in soft top compartment:</p>	Wiring, (S84/4) Wiring, (S84/4)

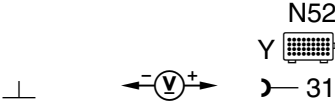

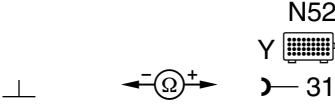

Electrical Test Program – Test

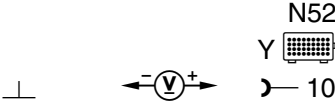
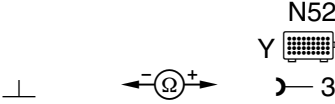
⇒		Test scope	Test connection	Test condition	Nominal value	Possible cause/Remedy
18.0		RB "Retracted" switch (S83/1)		Power soft top control module in diagnostic mode, see 22. Roll bar: lowered: raised:	0 – 1 V 11 – 14 V	Wiring, (S83/1), ⇒ 18.1 See SMS, Job no. 77-400 Wiring, (S83/1), ⇒ 18.1 N52
18.1		RB "Retracted" switch (S83/1)		Ignition: OFF Disconnect test cable from N52. Roll bar: lowered: raised:	0 – 5 Ω >20 kΩ	Wiring, (S83/1) Wiring, (S83/1)



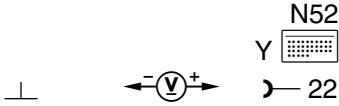

Electrical Test Program – Test

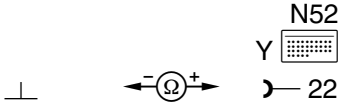
⇒		Test scope	Test connection	Test condition	Nominal value	Possible cause/Remedy
19.0	17	Left front door "window down" limit switch (S21/9)		Power soft top control module in diagnostic mode, see 22. Side windows: <p style="text-align: right;">down:</p> <p style="text-align: right;">up:</p>	<p style="text-align: right;">down: 0 – 1 V</p> <p style="text-align: right;">up: 11 – 14 V</p>	Wiring, (S21/9), ⇒ 19.1 See SMS, Job no. 77-410 Wiring, (S21/9), ⇒ 19.1 N52
19.1	17	Left front door "window down" limit switch (S21/9)		Ignition: OFF Disconnect test cable from N52. Side windows: <p style="text-align: right;">down:</p> <p style="text-align: right;">up:</p>	<p style="text-align: right;">down: 0 – 5 Ω</p> <p style="text-align: right;">up: >20 kΩ</p>	Wiring, (S21/9) Wiring, (S21/9)







Electrical Test Program – Test

⇒		Test scope	Test connection	Test condition	Nominal value	Possible cause/Remedy
20.0		Right front door "window down" limit switch (S21/8)		Power soft top control module in diagnostic mode, see 22. Side windows:	down: 0 – 1 V up: 11 – 14 V	Wiring, (S21/8), ⇒ 20.1 See SMS, Job no. 77-410 Wiring, (S21/8), ⇒20.1 N52
20.1		Right front power window motor (M10/4) Voltage supply control module		Ignition: OFF Disconnect test cable from N52 Side windows:	down: 0 – 5 Ω up: >20 kΩ	Wiring, (S21/8) Wiring, (S21/8)



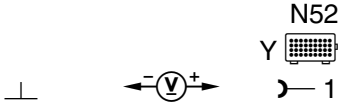

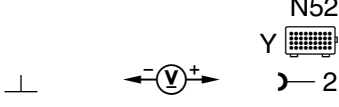

Electrical Test Program – Test

⇒		Test scope	Test connection	Test condition	Nominal value	Possible cause/Remedy
21.0	19 	VSS illogical signal  See 12/3, regarding hints when using dynamometer or brake test equipment.	– – –	–	–	With vehicle stationary, an acceleration of .49 g error signal was sent to the control module, or vehicle was tilted to a 23° angle. RB control module (N53).
22.0	20 	Installed hardtop recognized		See Hard top Locking Table in 24, (Limit switches)	Hard top installed.	With the hard top installed, at least one of the front or rear locks indicates "closed" or "locked".

Electrical Test Program – Test

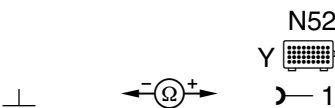
⇒		Test scope	Test connection	Test condition	Nominal value	Possible cause/Remedy
23.0		Power soft top switch (S84)	 <p>N52 Y  1</p>	Ignition: ON Power soft top switch (S84): Press close:	11 – 14 V 0 – 1 V	Switch (S84) and wiring, ⇒ 23.1, N52 Switch (S84) and wiring, ⇒ 23.1, N52
			 <p>N52 Y  2</p>	Ignition: ON Power soft top switch (S84): Press open:	11 – 14 V 0 – 1 V	Switch (S84) and wiring, ⇒ 23.1, N52 Switch (S84) and wiring, ⇒ 23.1, N52

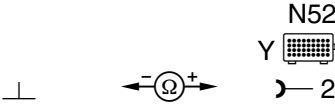





Electrical Test Program – Test

⇒		Test scope	Test connection	Test condition	Nominal value	Possible cause/Remedy
23.1		Power soft top switch (S84) and wiring	 <p>N52 Y  1</p>  <p>N52 Y  2</p>	Disconnect test cable from N52 Power soft top switch (S84): In rest position: Press in direction close: Power soft top switch (S84): In rest position: Press in direction open:	>20 kΩ 0 – 5 Ω >20 kΩ 0 – 5 Ω	Wiring, (S84) Wiring, (S84) Wiring, (S84) Wiring, (S84)



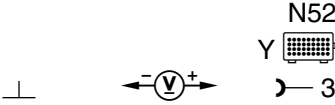

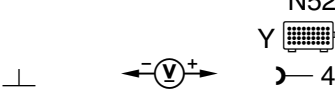

11.2 Roadster Soft Top (RST), Roll Bar (RB) (Manual Deployment)

Model 129

Electrical Test Program – Test

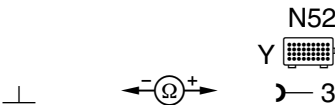
⇒		Test scope	Test connection	Test condition	Nominal value	Possible cause/Remedy
24.0		RB switch (S83) (manual operation)	 <p>N52 Y  3</p>	Ignition: ON Roll bar switch (S83): Press in direction Up	4 – 6 V 0 – 1 V	Switch (S83) and wiring, ⇒ 24.1, N52 Switch (S83) and wiring, ⇒ 24.1, N52
			 <p>N52 Y  4</p>	Ignition: ON Roll bar switch (S83): Press in direction Lower	4 – 6 V 0 – 1 V	Switch (S83) and wiring, ⇒ 24.1, N52 Switch (S83) and wiring, ⇒ 24.1, N52

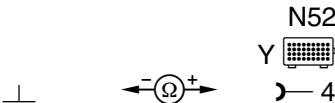
Electrical Test Program – Test

⇒		Test scope	Test connection	Test condition	Nominal value	Possible cause/Remedy
24.1		RB switch (S83) and wiring	 <p>N52 Y  3</p>	Disconnect test cable from N52 Roll bar switch (S83): In rest position: Press in direction Raise	>20 kΩ 0 – 5 Ω	Wiring, (S83) Wiring, (S83)
			 <p>N52 Y  4</p>	Roll bar switch (S83): In rest position: Press in direction Lower:	>20 kΩ 0 – 5 Ω	Wiring, (S83) Wiring, (S83)

Electrical Test Program – Test

⇒		Test scope	Test connection	Test condition	Nominal value	Possible cause/Remedy
25.0		RB control module (N53)	<p>N52 Y 11</p> <p>N52 Y 12</p>	Ignition: ON	>2.4 V >2.4 V	Wiring, Fault in the Roll bar system, see DM, B&A, Vol. 6, section 19.2, N53, See SMS, Job no. 91-840 Wiring, Fault in the Roll bar system, see DM, B&A, Vol. 6, section 19.2, N53
26.0		Roll Bar (Crash Deployment)	<p>N52 Y 9</p>	Ignition: ON RB switch (S83): Press in direction "up" (approx. 10 seconds) Using RB switch (S83): Lower roll bar	Roll bar is lowered.	There has been a "Crash Deployment". Upon lowering the roll bar, the impulse (DTC) is erased.
27.0		Limit switch un-logical	— — —	Test limit switch via diagnostic mode, see 22	—	Limit switch is faulty.
28.0		Operation time span exceeded	— — —	Soft top completely open or closed. Ignition: ON (approx. 5 minutes)	Fault will erase itself.	N52







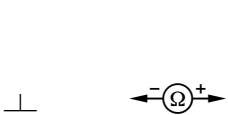

Electrical Test Program – Test

⇒		Test scope	Test connection	Test condition	Nominal value	Possible cause/Remedy
29.0	27	Low system voltage 		Ignition: ON Use battery charger each time when performing soft top tests.	11 – 14 V	Voltage supply, 23⇒ 2.0
30.0	28	Speedometer signal See 12/3, regarding hints when using dynamometer or brake test equipment.		Drive vehicle at approx. 25 mph.	approx. 6 V ~	Wiring, Electronic speedometer (A1p8) (see DM, Info. & Com., section 1.1), Combination relay module (N10/2), Pushbutton control module (N22), Radio (A2), Multi-function connector block (X30/1).
31.0	29	VSS signal See 12/3, regarding hints when using dynamometer or brake test equipment.		Ignition: ON Rotate left front wheel at approx. 1 revo./second	2.5 – 4 V	Wiring, ABS control module (N30), Power soft top control module (N52).

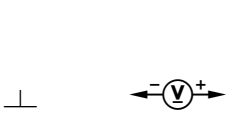
Electrical Test Program – Test

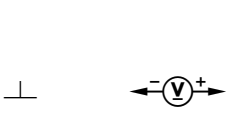
⇒		Test scope	Test connection	Test condition	Nominal value	Possible cause/Remedy
32.0		Power soft top operation locked See 12/3, regarding hints when using dynamometer or brake test equipment.	— — —	—	—	Fault only occurs with impluse readouts (DTCs): 19, 28 or 29
33.0		Left front power window switch (S21/1)		Ignition: ON	11 – 14 V	Wiring, Power soft top control module (N52), (S21/1), ⇒ 33.1
					11 – 14 V	Wiring, Power soft top control module (N52), (S21/1), ⇒ 33.2
33.1		Left front power window switch (S21/1) Close, lower limit stop control		Ignition: OFF Disconnect test cable from N52, Press switch (S21/1) back to second detent and then forward.	>20 kΩ	Wiring, (S21/1),
					0 – 1 Ω	Wiring, (S21/1)

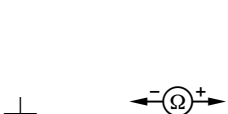





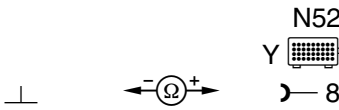
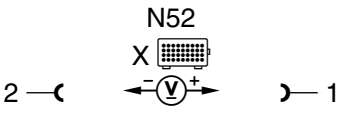
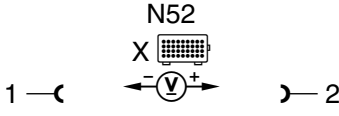
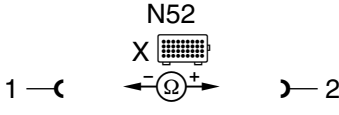
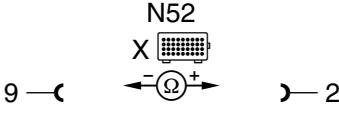

Electrical Test Program – Test

⇒		Test scope	Test connection	Test condition	Nominal value	Possible cause/Remedy
33.2		Left front power window switch (S21/1) Open	 N52 Y  6	Ignition: OFF Disconnect test cable from N52, Press switch (S21/1) back to first and second detent.	>20 kΩ 0 – 1 Ω	Wiring, (S21/1) Wiring, (S21/1)
34.0		Right front power window switch (S21/2)	 N52 Y  7	Ignition: ON	11 – 14 V	Wiring, (S21/2), ⇒ 34.1, Power soft top control module (N52).
			 N52 Y  8		11 – 14 V	Wiring, (S21/2), ⇒ 34.2, Power soft top control module (N52).
34.1		Right front power window switch (S21/2) Close, lower limit stop control	 N52 Y  7	Ignition: OFF Disconnect test cable from N52, Press switch (S21/1) back to second detent and then forward.	>20 kΩ 0 – 1 Ω	Wiring, (S21/2) Wiring, (S21/2)

Electrical Test Program – Test

⇒		Test scope	Test connection	Test condition	Nominal value	Possible cause/Remedy
34.2		Right front power window switch (S21/2) Open		Ignition: OFF Disconnect test cable from N52, Press switch (S21/1) back to first and second detent.	>20 kΩ 0 – 1 Ω	Wiring, (S21/2) Wiring, (S21/2)
35.0		Left front power window motor (M10/3) Voltage	 	Ignition: ON Switch (S21/1): At rest: Press in direction " open " Press in direction " close "	0 – 1 V 11 – 14 V 11 – 14 V	Power soft top control module (N52) Wiring, (M10/3), ⇒ 35.1, (N52). Wiring, (M10/3), ⇒ 35.1, (N52).
35.1		Left front power window motor (M10/3) (with wiring)	 	Ignition: OFF Disconnect test cable from N52.	0.5 – 2 Ω >20 kΩ	Wiring, (M10/3), See SMS, Job no. 82-600 Wiring, (M10/3)

Electrical Test Program – Test

⇒		Test scope	Test connection	Test condition	Nominal value	Possible cause/Remedy
36.0		Right front power window motor (M10/4) Voltage	<p style="text-align: center;">N52 Z </p> <p>2 —(—  —) 1</p> <p style="text-align: center;">N52 Z </p> <p>1 —(—  —) 2</p>	Ignition: ON Switch (S21/1): <p style="text-align: center;">At rest:</p> Press in direction " open " Press in direction " close "	0 – 1 V 11 – 14 V 11 – 14 V	Power soft top control module (N52). Wiring, (M10/4), ⇒ 36.1, (N52). Wiring, (M10/4), ⇒ 36.1, (N52).
36.1		Right front power window motor (M10/4) (with wiring)	<p style="text-align: center;">N52 Z </p> <p>1 —(—  —) 2</p> <p style="text-align: center;">N52 Z </p> <p>12 —(—  —) 2</p>	Ignition: OFF Disconnect test cable from N52.	0.5 – 2 Ω >20 kΩ	Wiring, (M10/4), See SMS, Job no. 82-600 Wiring, (M10/4).
37.0		Indicator lamp in power soft top switch (S84)		Ignition: ON	Indicator lamp in power soft top switch illuminates briefly.	Wiring, (S84).

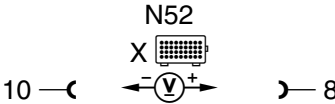
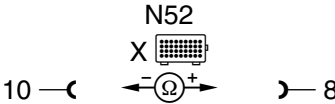
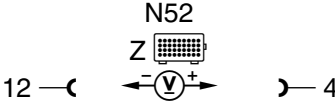

Electrical Test Program – Test

⇒		Test scope	Test connection	Test condition	Nominal value	Possible cause/Remedy
38.0		Main valve (A7/5y1) Activation (deleted as of VIN 1F-083891)		Ignition: ON Roll bar retracted. Press power soft top switch (S84) to "open" or "close".	0 – 1 V 11 – 14 V	Power soft top control module (N52). 23⇒ 39.0, (N52)
39.0		Main valve (A7/5y1) with wires		Disconnect test cable from N52. See connection schematic X	5 – 15 Ω	Wiring, (A7/5y1)
40.0		Rear locks valve (Y56y2) Activation		Ignition: ON Unlock hard top, or unlock fabric bow using power soft top switch (S84). Lock hard top, or unlock fabric bow using power soft top switch (S84).	11 – 14 V 0 – 1 V	23⇒ 41.0, (N52). (N52).

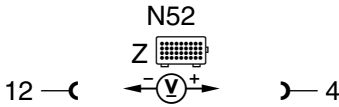
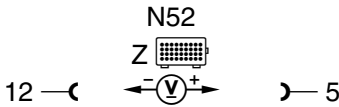
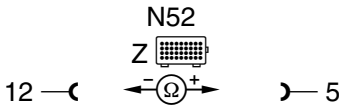
Electrical Test Program – Test

⇒		Test scope	Test connection	Test condition	Nominal value	Possible cause/Remedy
41.0		Rear locks valve (Y56y2) with wiring		Disconnect test cable from N52.	5 – 15 Ω	Wiring, (Y56y2), If nominal value is OK: Check if rear locks valve (Y56y2) is mechanically jammed.
42.0		Center locks valve (Y56y3) Activation		Ignition: ON Using power soft top switch (S84): " Open " soft top compartment cover. " Close " soft top compartment cover.	11 – 14 V 0 – 1 V	23⇒ 43.0, (N52). (N52).
43.0		Center locks valve (Y56y3) with wiring		Disconnect test cable from N52.	5 – 15 Ω	Wiring, (Y56y3), If nominal value is OK: Check if center locks valve (Y56y3) is mechanically jammed.



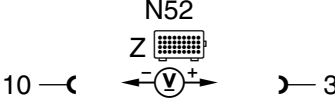
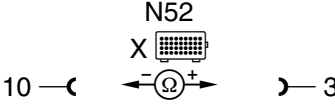



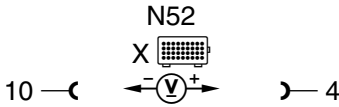
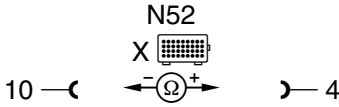
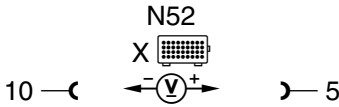



Electrical Test Program – Test

⇒		Test scope	Test connection	Test condition	Nominal value	Possible cause/Remedy
47.0		Soft top compartment cover valve (Y56y5) with wiring		Disconnect test cable from N52.	5 – 15 Ω	Wiring, (Y56y5), If nominal value is OK: Check if soft top compartment cover valve (Y56y5) is mechanically jammed.
48.0		Soft top "open" valve (Y55y6) Activation		Ignition: ON Using power soft top switch (S84): "Open " soft top. "Close" soft top.	11 – 14 V 0 – 1 V	23⇒ 49.0, (N52). (N52).
49.0		Soft top "open" valve (Y55y6) with wiring		Disconnect test cable from N52.	5 – 15 Ω	Wiring, (Y55y6), If nominal value is OK: Check if soft top "open" valve (Y55y6) is mechanically jammed.

Electrical Test Program – Test

⇒		Test scope	Test connection	Test condition	Nominal value	Possible cause/Remedy
50.0		Soft top "close" valve (Y55y7) Activation		Ignition: ON Using power soft top switch (S84): "Close " soft top. "Open " soft top.	11 – 14 V 0 – 1 V	23⇒ 51.0, (N52). (N52).
51.0		Soft top "close" valve (Y55y7) with wiring		Disconnect test cable from N52.	5 – 15 Ω	Wiring, (Y55y7), If nominal value is OK: Check if soft top "close" valve (Y55y7) is mechanically jammed.
52.0		Fabric bow "raise" valve (Y55y8) Activation		Ignition: ON Using power soft top switch (S84): "Raise " fabric bow or "Close " soft top. Using power soft top switch (S84): "Lower " fabric bow or "Close " power soft top compartment cover.	11 – 14 V 0 – 1 V	23⇒ 53.0, (N52). (N52).

Electrical Test Program – Test

⇒		Test scope	Test connection	Test condition	Nominal value	Possible cause/Remedy
53.0		Fabric bow "raise" valve (Y55y8) with wiring	<p style="text-align: center;">N52 X </p> <p>10 —  ←  → 5</p>	Disconnect test cable from N52.	5 – 15 Ω	Wiring, (Y55y8), If nominal value is OK: Check if fabric bow "raise" valve (Y55y8) is mechanically jammed.
54.0		Fabric bow "lower" valve (Y55y9) Activation	<p style="text-align: center;">N52 X </p> <p>10 —  ←  → 6</p>	Ignition: ON Using power soft top switch (S84): "Lower " fabric bow. Using power soft top switch (S84): "Raise " fabric bow.	11 – 14 V 0 – 1 V	23⇒ 55.0, (N52). (N52).
55.0		Fabric bow "lower" valve (Y55y9) with wiring	<p style="text-align: center;">N52 X </p> <p>10 —  ←  → 6</p>	Disconnect test cable from N52.	5 – 15 Ω	Wiring, (Y55y9), If nominal value is OK: Check if fabric bow "lower" valve (Y55y9) is mechanically jammed.

Electrical Test Program – Test

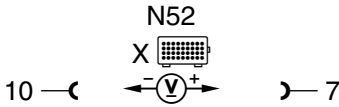
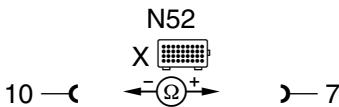
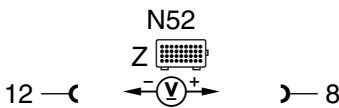
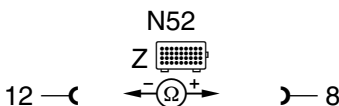
⇒		Test scope	Test connection	Test condition	Nominal value	Possible cause/Remedy
56.0		Rod side valve (Y57y10) Activation		Ignition: ON Press power soft top switch (S84), Or RB switch (S83).	0 – 1 V 11 – 14 V	Power soft top control module (N52). 23⇒ 57.0, Wiring, (N52).
57.0		Rod side valve (Y57y10) with wiring		Disconnect test cable from N52.	5 – 15 Ω	Wiring, (Y57y10).
58.0		Piston side valve (Y57y11) Activation		Ignition: ON Press power soft top switch (S84) or RB switch (S83): To " raise " roll bar or to " lower " roll bar.	11 – 14 V 0 – 1 V	23⇒ 59.0, (N52). (N52).
59.0		Piston side valve (Y57y11) with wiring		Disconnect test cable from N52.	5 – 15 Ω	Wiring, (Y57y11) If nominal value is OK: Check if piston side valve (Y55y11) is mechanically jammed.

Electrical Test Program – Test

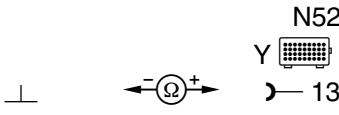
⇒		Test scope	Test connection	Test condition	Nominal value	Possible cause/Remedy
61.0		Actuator: Left door actuator (S47), Right door actuator (S48), Trunk lid lock actuator (S49)		Vehicle locked via RCL	<10 Ω	Wiring, Actuators: (S47), (S48), (S49).