

Hydraulic Test Program – Preparation for Test

Before beginning the test, check the oil level in the hydraulic unit reservoir and top up if needed (Refer to Maintenance Manual, Vol. 3, Job No. 7710).

Brief description:

In order to make an accurate visual inspection for oil loss from the hydraulic system, the windscreen or other personal items should be removed from the vehicle.

The hydraulic circuits and components for each soft top operation can be tested separately.

The soft top can be placed in all required positions either by the power soft top switch or (if needed, with ignition: **OFF**) by hand.

All of the locks can be locked or unlocked with the soft top wrench.



Disconnected hydraulic lines should be held in a container (connect a transparent hose such as windshield washer hose).

Hydraulic components that leak should be replaced. During pressure tests, the valve block connections **must** be plugged with threaded plug 129 589 00 91 01.

If hydraulic components need to be replaced, the disconnected hydraulic lines must be plugged with plug 129 589 00 91 07, while the connections of valve blocks, hydraulic cylinders and hydraulic manifolds must be plugged **immediately** using plug 129 589 00 91 11 to prevent the possible entry of dirt.

Special Tools

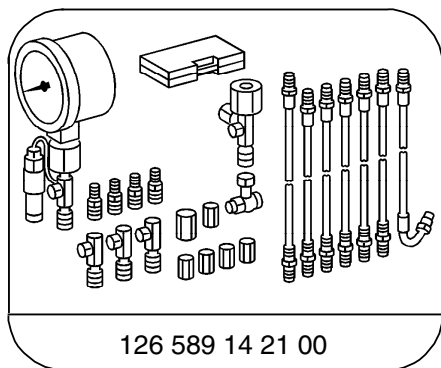

126 589 14 21 00

Tester

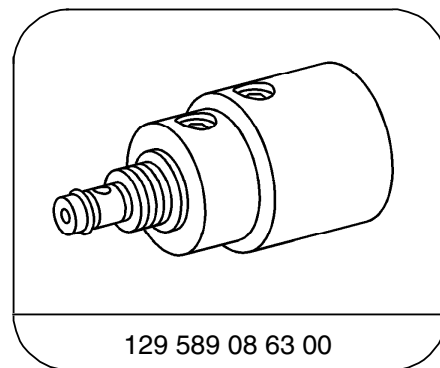

129 589 08 63 00

Check valve

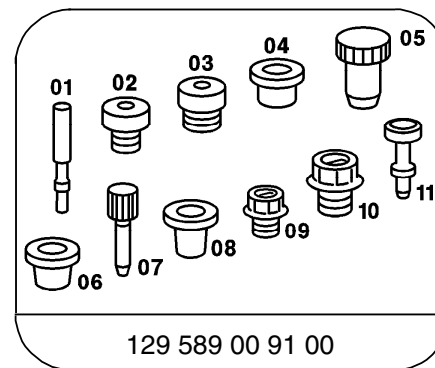

129 589 00 91 00

Set of plugs

Hydraulic Test Program – Preparation for Test

Test equipment; See MBUSA Standard Service Equipment Program

Description	Brand, model, etc.
Graduated beaker (0.5 liter, 10 ml graduations)	Local purchase

Hydraulic Test Line,
Part no. 129 806 34 83

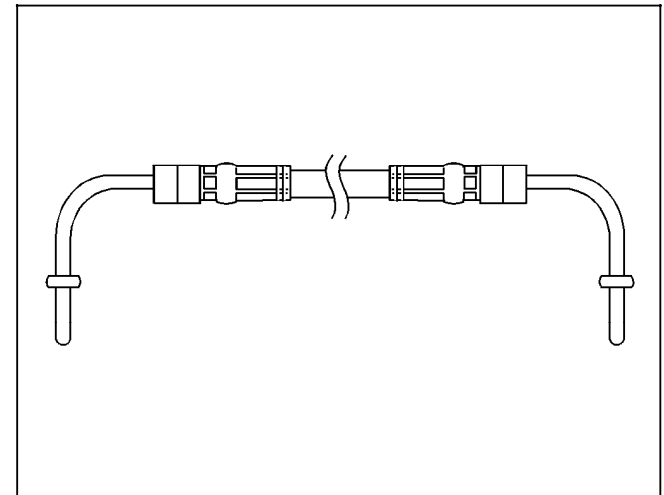

P77.37-0317-01

Figure 1