

Electrical Test Program – Component Locations

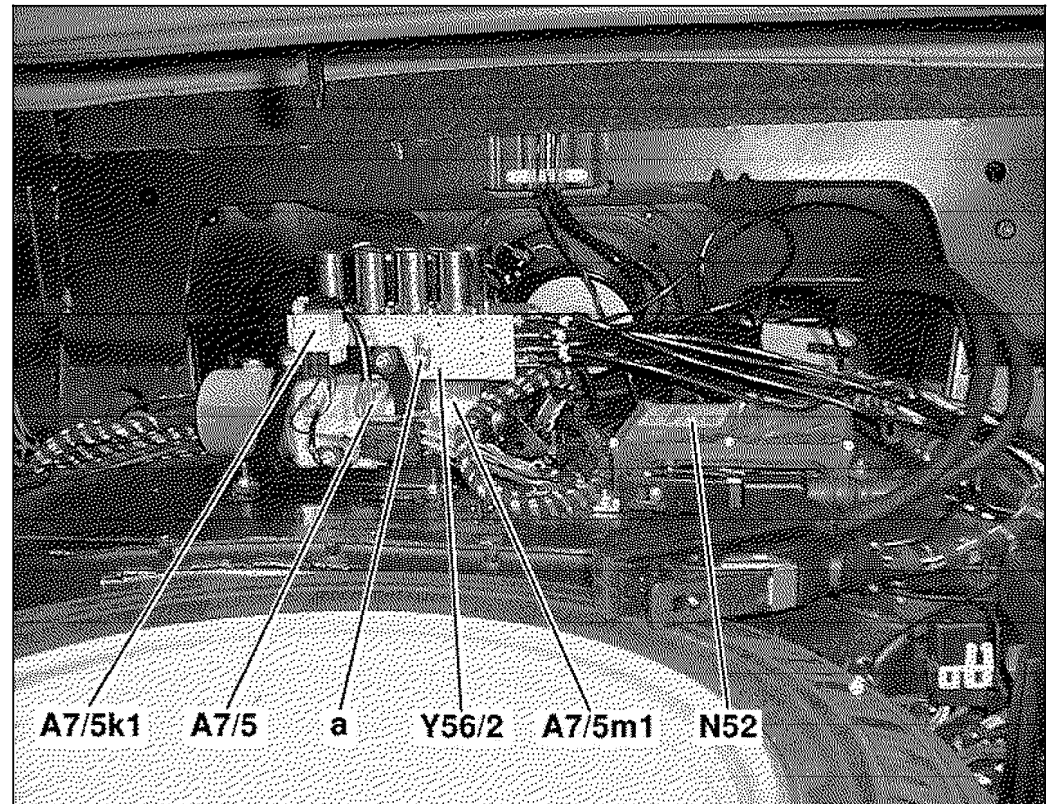

- A7/5 Rollbar hydraulic unit (power soft top)
- A7/5k1 Hydraulic unit relay
- A7/5m1 Motor
- N52 Power soft top control module
- Y56/2 Soft top control valve block (7 connections)
- a Manually switchable check valve for emergency operation of soft top

P77.37-2007-11

Electrical Test Program – Component Locations

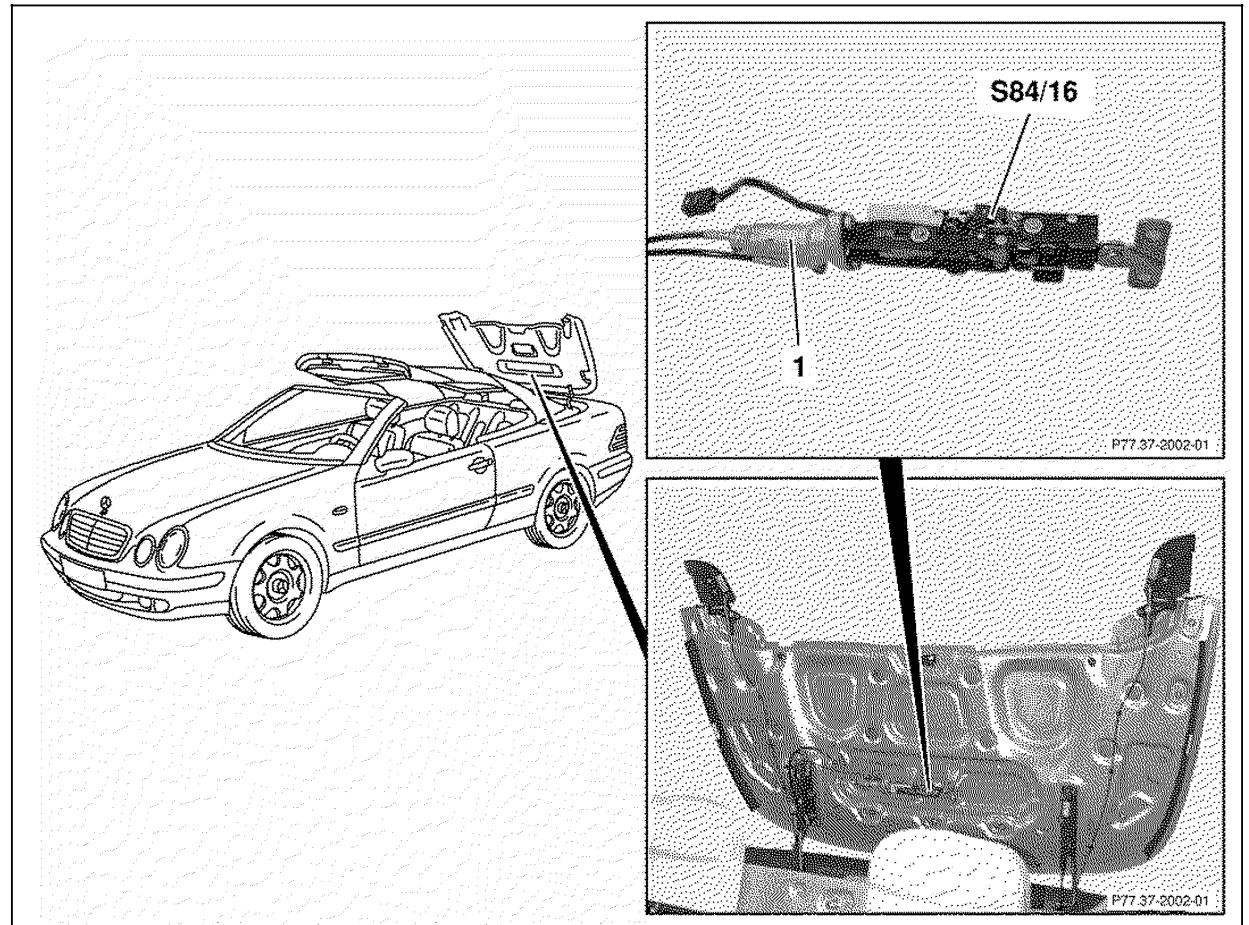

- 1 Soft top bow hydraulic cylinder (locking/unlocking)
- S84/16 Soft top bow locked limit switch

P77.37-2018-06

Electrical Test Program – Component Locations

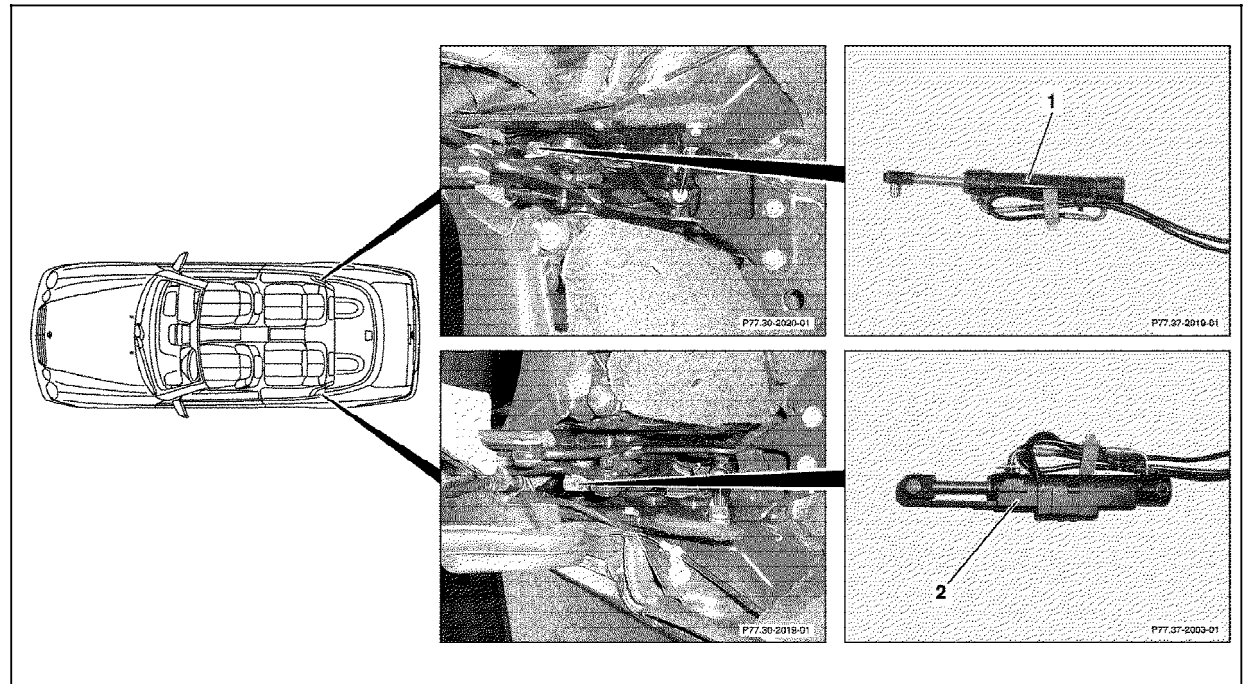

- 1 Right soft top bow hydraulic cylinder (raising/lowering)
- 2 Left soft top bow hydraulic cylinder (setting up/lowering)

P77.37-2020-09

Electrical Test Program – Component Locations

- N72s3 Left rear power window switch
- N72s4 Right rear power window switch
- N72s15 Remote trunk release (RTR) switch
- S21/1 Left front power window switch (front center console)
- S21/2 Right front power window switch (front center console)
- S84 Power soft top switch

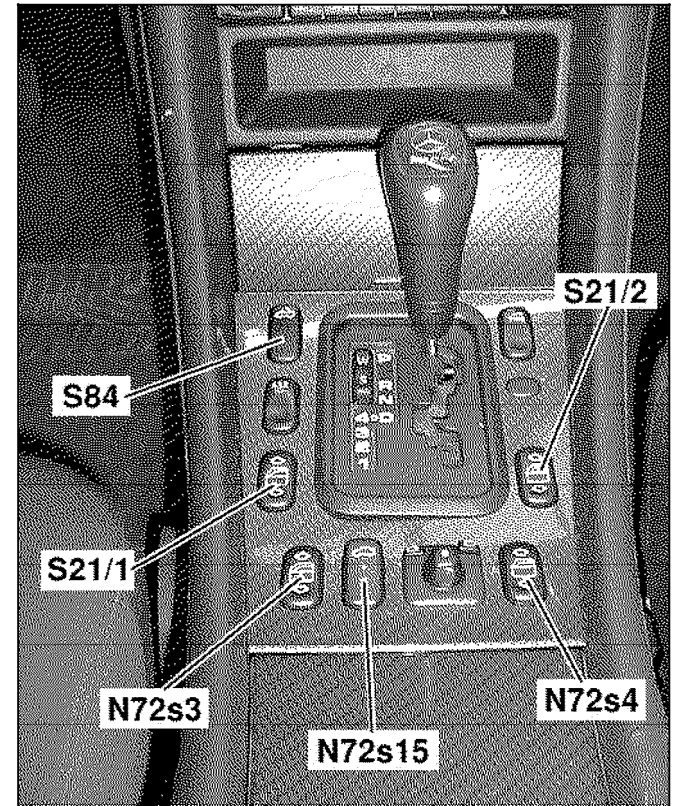

P68.20-2006-02

Electrical Test Program – Component Locations

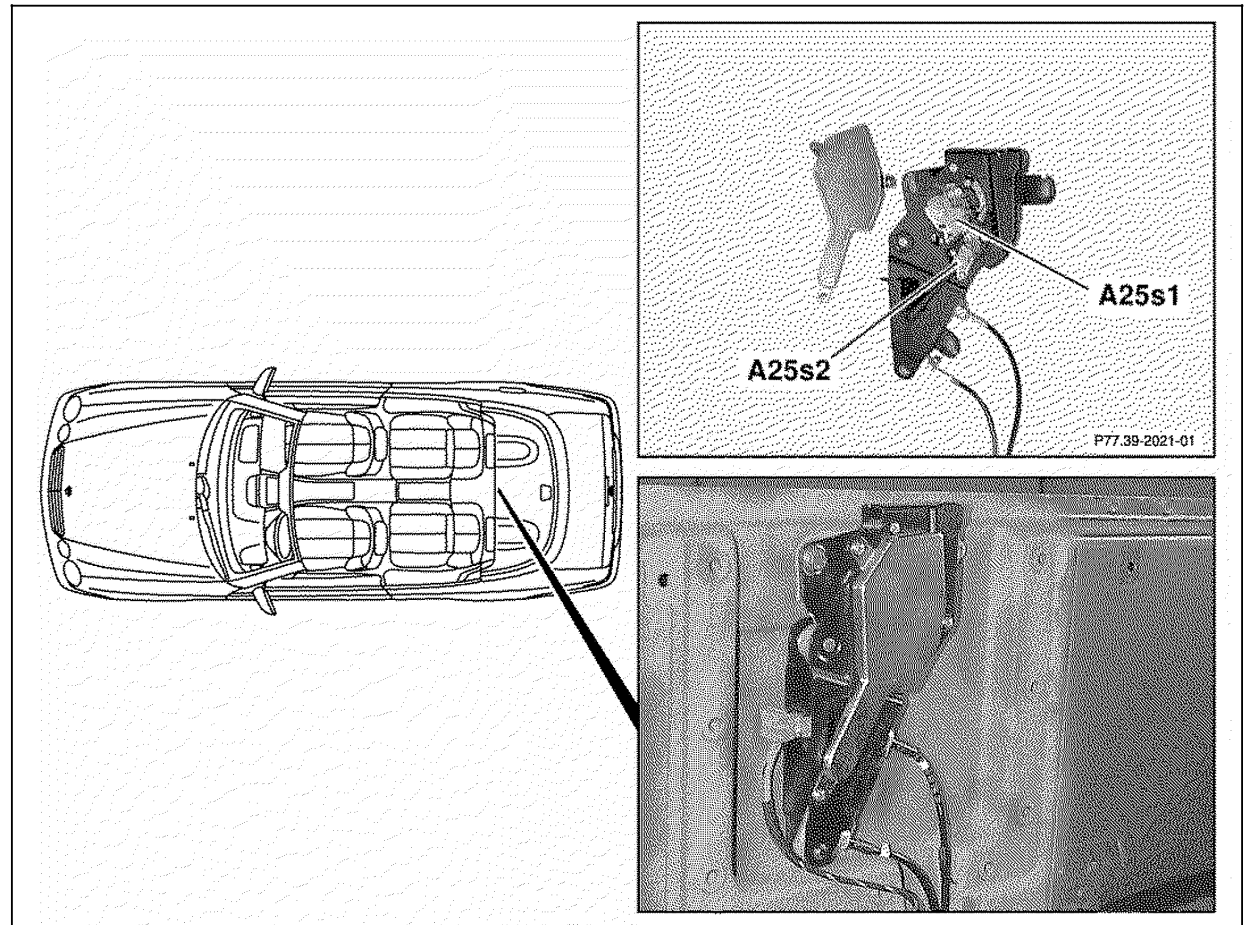

A25s1 Cover "closed" switch
A25s2 Cover "locked" switch

P77.39-2022-06

Electrical Test Program – Component Locations

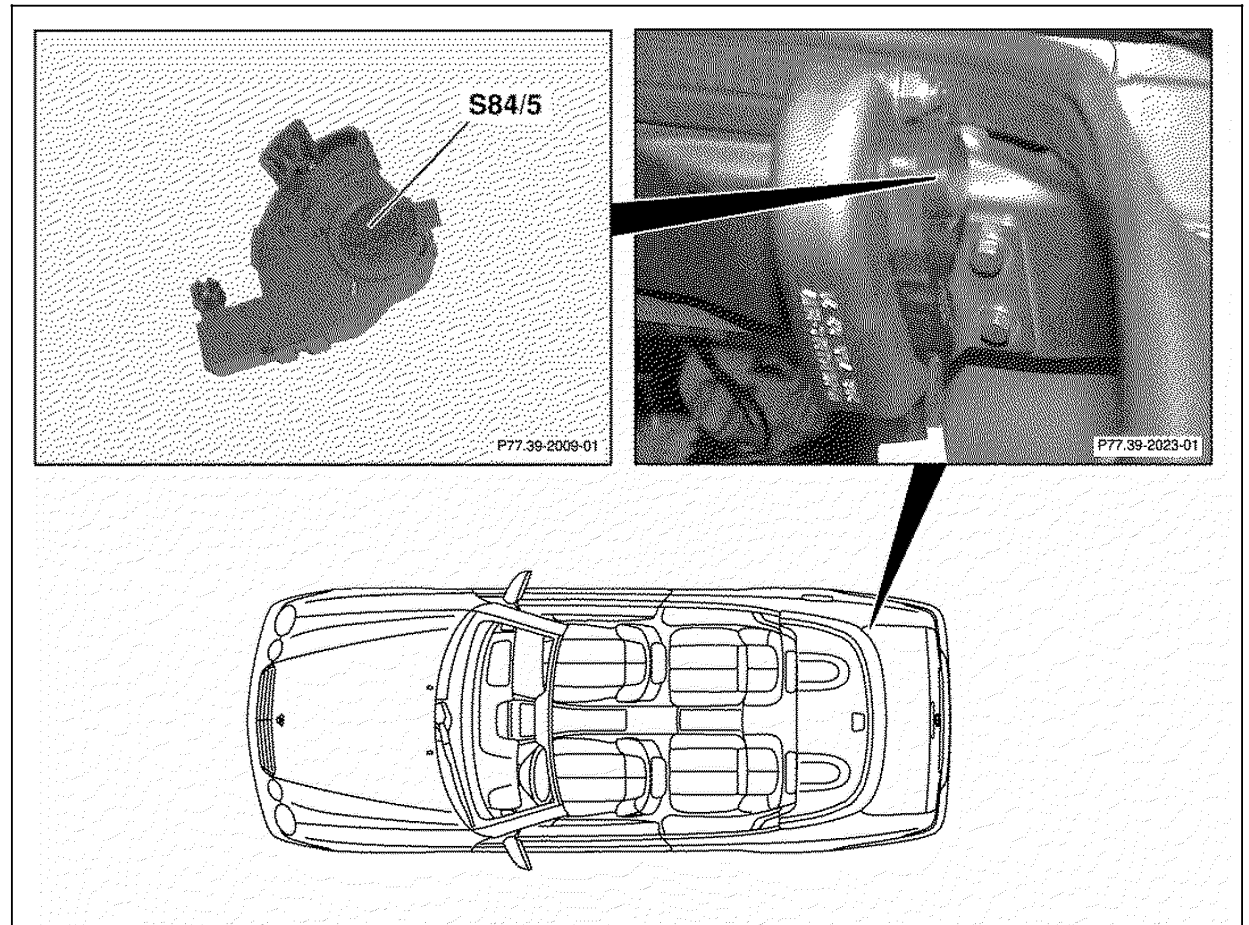

S84/5 Soft compartment cover open switch

P77.39-2010-06

Electrical Test Program – Component Locations

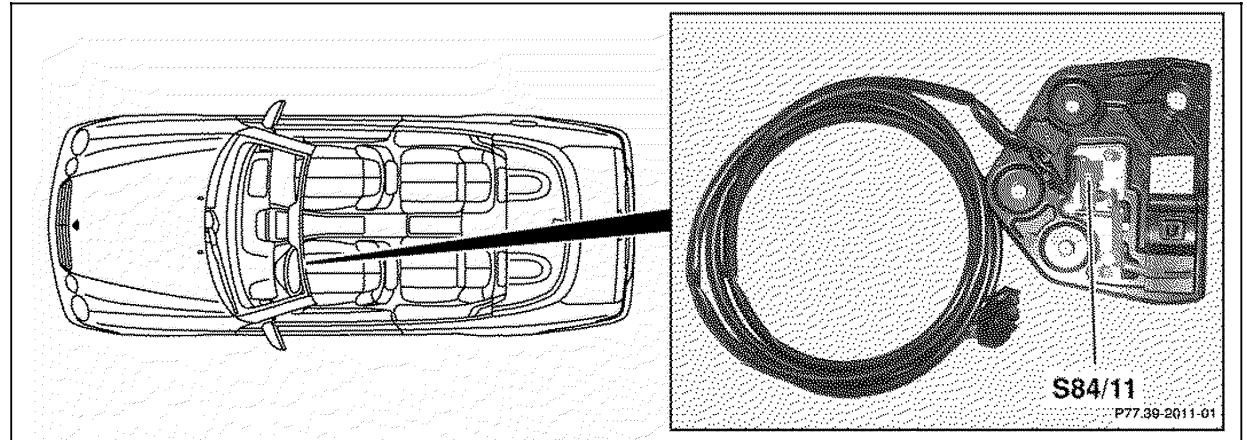

S84/11 Soft top "locked" (left) limit switch

P77.39-2012-04

Electrical Test Program – Component Locations

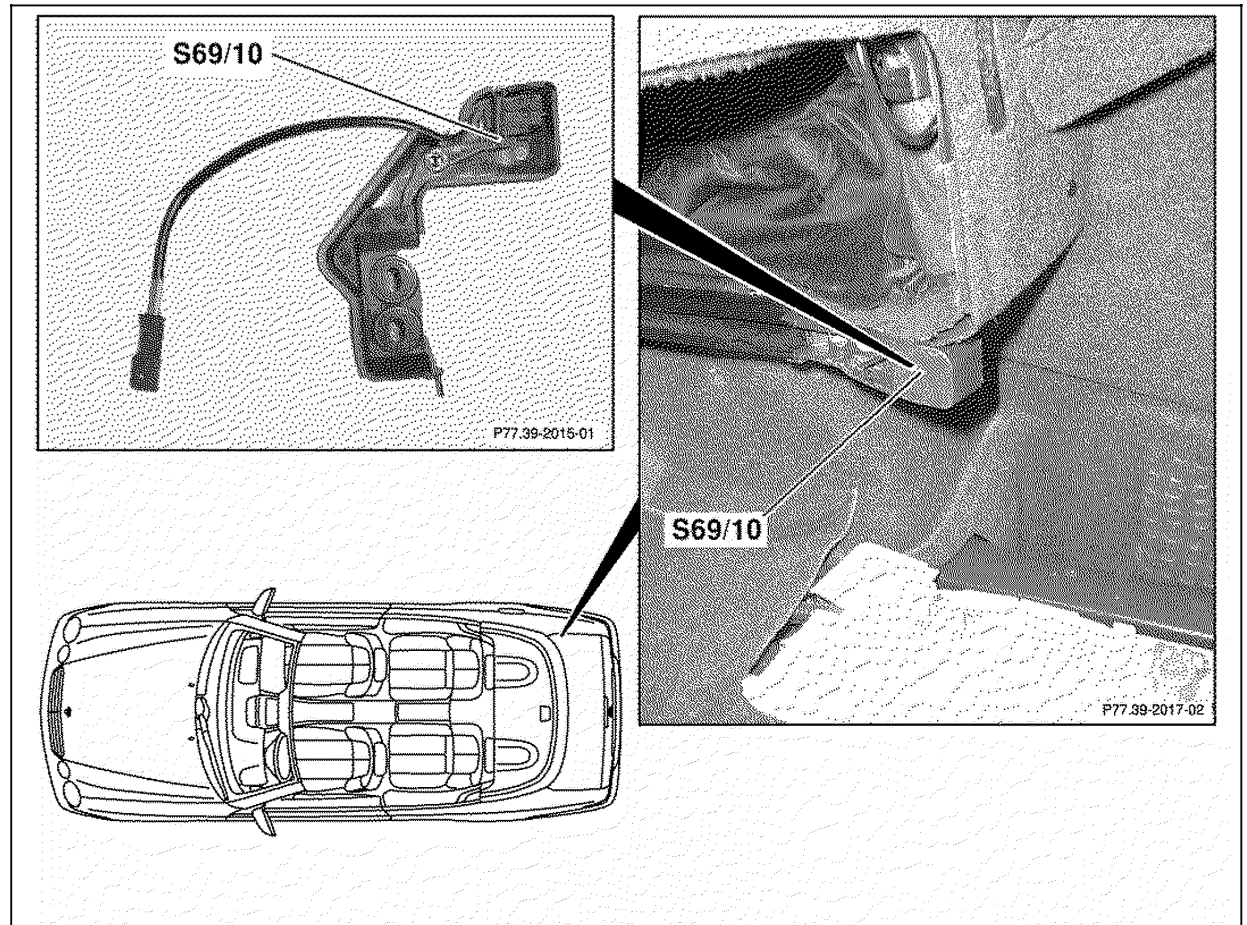

S69/10 Retractable luggage cover engaged limit switch

P77.39-2016-06

Electrical Test Program – Component Locations

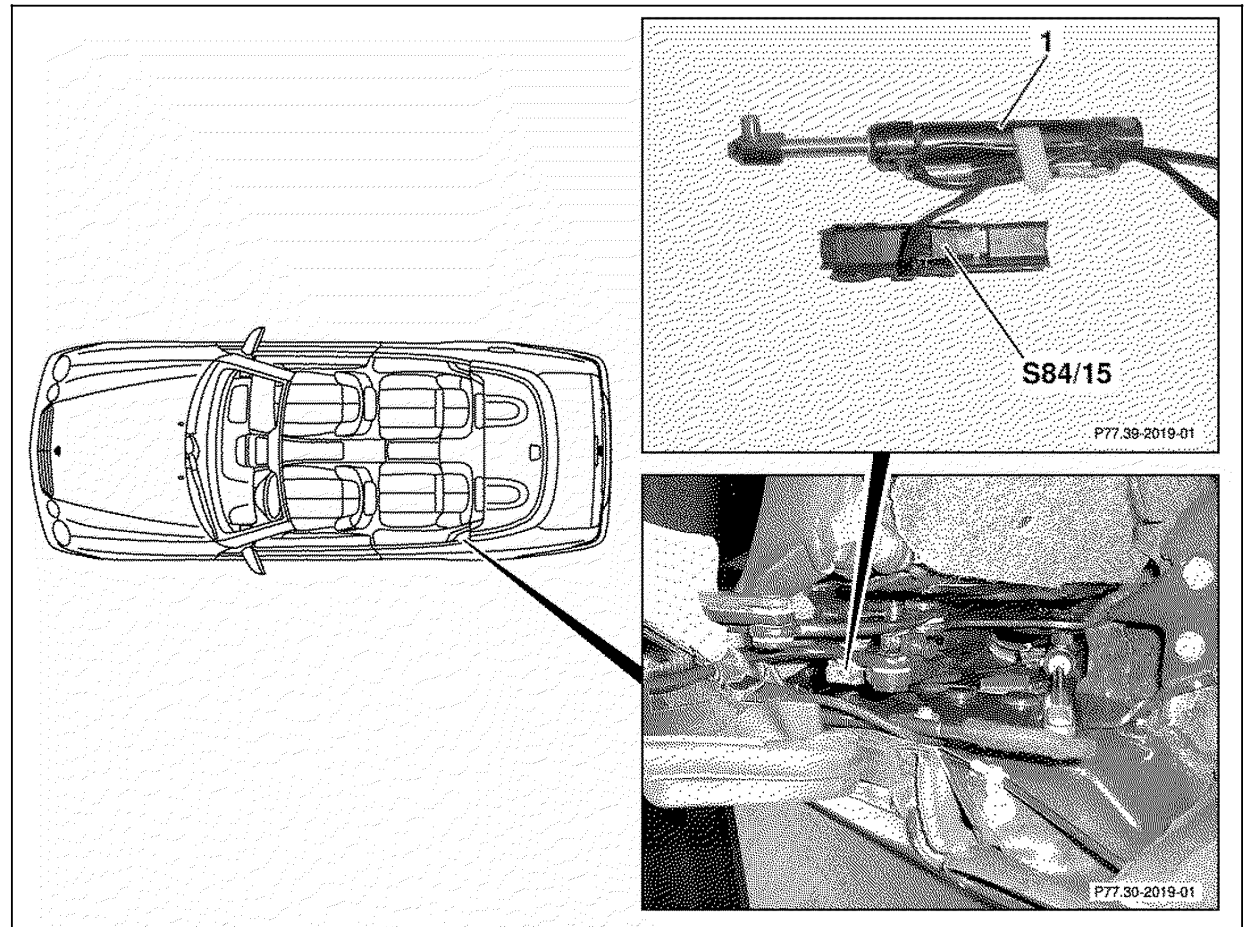

S84/15 Soft top fabric bow up/down limit switch

P77.39-2020-06

Electrical Test Program – Component Locations

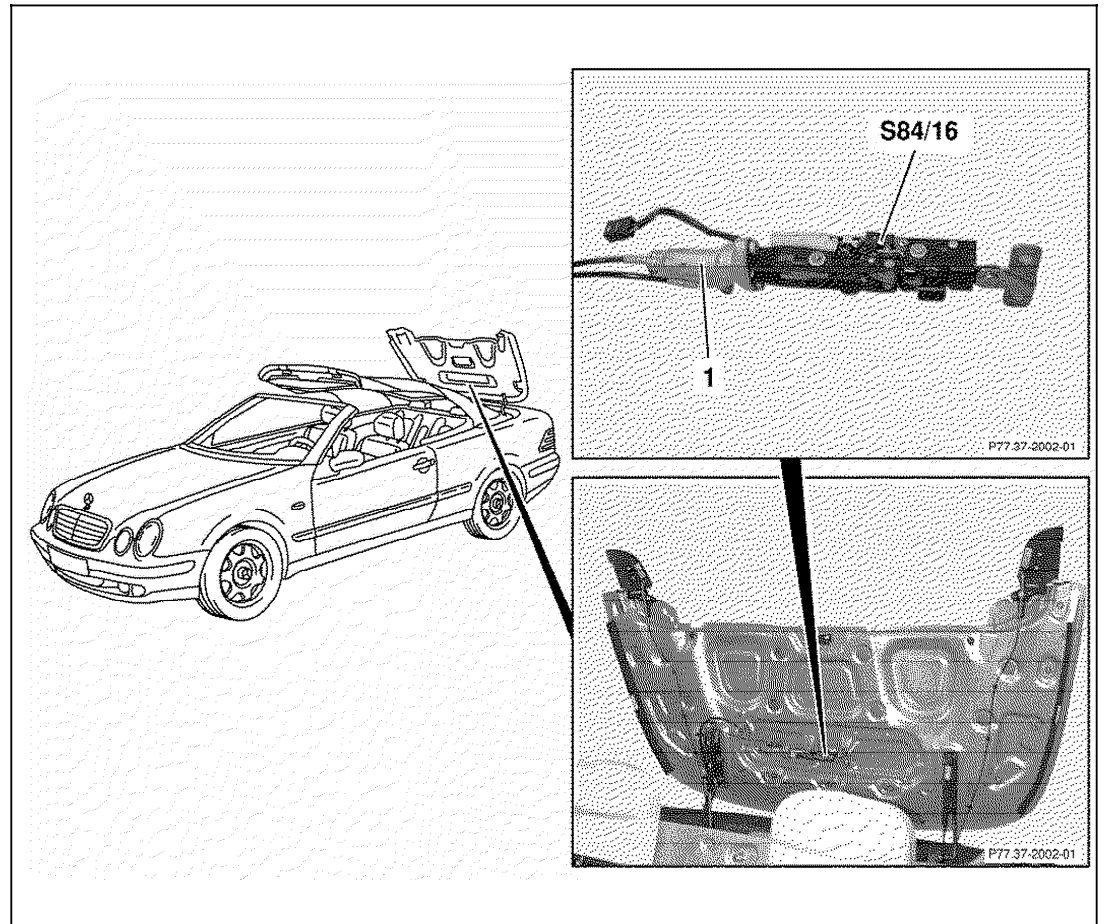

S84/16 Soft top fabric bow "locked" limit switch
1 Soft top bow hydraulic cylinder (locking/unlocking)

P77.37-2018-06