

















Electrical Test Program – Test

⇒		Test scope	Test connection	Test condition	Nominal value	Possible cause/remedy	
1.0	B1726	PSE control module (A37) Voltage supply	Circuit 30	A37 3 —  —  — 4 (2)	—	11 – 14 V	Wiring.
			Circuit 30	A37 3 —  —  — 2 (2)	—	11 – 14 V	Wiring.
2.0	B1712	Left front door switch (S17/3) Alarm circuit	A37  — 60 —  — 4 (1.14)	A37 4 (2)	Left front door: closed open	< 1 V 11 – 14 V	Wiring, S17/3
3.0	B1713	Right front door switch (S17/4) Alarm circuit	A37  — 62 —  — 4 (1.16)	A37 4 (2)	Right front door: closed open	< 1 V 11 – 14 V	Wiring, S17/4
4.0	B1710	Trunk lock/trunk illumination rotary latch selector switch (S69/12) Alarm circuit	A37  — 59 —  — 4 (1.13)	A37 4 (2)	Trunk lid: closed open	< 1 V 11 – 14 V	Wiring, S69/12





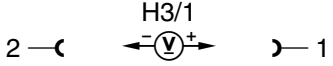

Electrical Test Program – Test

⇒		Test scope	Test connection	Test condition	Nominal value	Possible cause/remedy
5.0	B1711	Engine hood (S62) Alarm circuit	A37 5 —┐ ←(V)→ ─┐ 4 (2)	Engine hood: closed open	< 1 V 11 – 14 V	Wiring, S62
6.0		Glove box switch (ATA) (S62/7) Alarm circuit	A37 16 —┐ ←(V)→ ─┐ 4 (2)	Glove box: closed open	< 1 V 11 – 14 V	Wiring, S62/7
7.0	B1722	Stop lamp switch (S9/1) Alarm circuit	A37 3 —┐ ←(V)→ ─┐ 12 (2)	Ignition: ON Apply service brake:	< 1 V 11 – 14 V	Wiring, S9/1
8.0		Alarm horn (H3) (only USA) As of 06/97: all vehicles until 06/98	A37 3 —┐ —┐ 4 (4) (2)	Insert bridge. Use bridges with 124 589 37 63 00 safety cables only.	Alarm sounds.	Wiring, H3

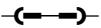
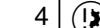
Electrical Test Program – Test

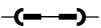
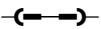
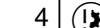
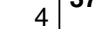
⇒		Test scope	Test connection	Test condition	Nominal value	Possible cause/remedy
9.0		Alarm siren with auxiliary battery (H3/1) Function (as of 06/98)		HHT activation: Alarm siren test.	Siren emits short acoustic signal for .2 sec seconds.	⇒ 9.1
9.1		Voltage supply		Disconnect connector at H3/1	11 – 14 V	Wiring.
9.2		Trigger alarm		Activate ATA. Wait 15 seconds. Disconnect connector at H3/1  To interrupt alarm, reconnect H3/1 connector and deactivate ATA.	Acoustical and Optical alarm function.	H3/1 Wiring, A37
10.0		<i>Not applicable for U.S.A. vehicles</i>				

Electrical Test Program – Test

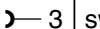
⇒		Test scope	Test connection	Test condition	Nominal value	Possible cause/remedy	
11.0		Headlamp Alarm circuit	A37 1 (2) 	A37 4 (4)  Use bridges with 124 589 37 63 00 safety cables only.	Insert bridge. 	Headlamps are illuminated continuously.	Wiring, Illumination control module (N7-1)
12.0		Taillamp Alarm circuit	A37 1 (2)  4 (2) 	A37 4 (4)  4 (4)  Use bridges with 124 589 37 63 00 safety cables only.	Insert bridge. 	Left/right taillamps are illuminated continuously.	Wiring, Illumination control module (N7-1)
13.0		ATA status/towing protection switch (S85/3) Deactivate anti-tow protection	A37 6 —  (3) 	A37 3 (2) 	Press top part of S85/3 switch.	< 1 Ω	Wiring, S85/3

Electrical Test Program – Test – Connector Layouts

Connector Layout - Pneumatic control module (A37)

- 1 Connector 1 (PSE control lines)
- 1 Connector 2 (PSE voltage supply)
- 3 Connector 3 (ATA control lines)
- 4 Connector 4 (ATA electrical consumer connections)

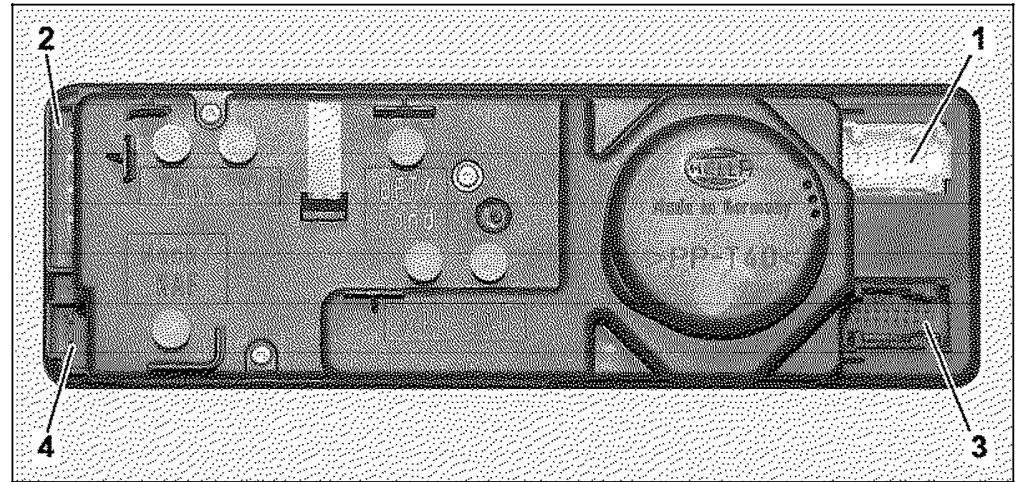

P80.20-2037-10

Connector Layout - ATA tow sensor (B33)

- 1 Data
- 2 Voltage supply (+)
- 5 Ground

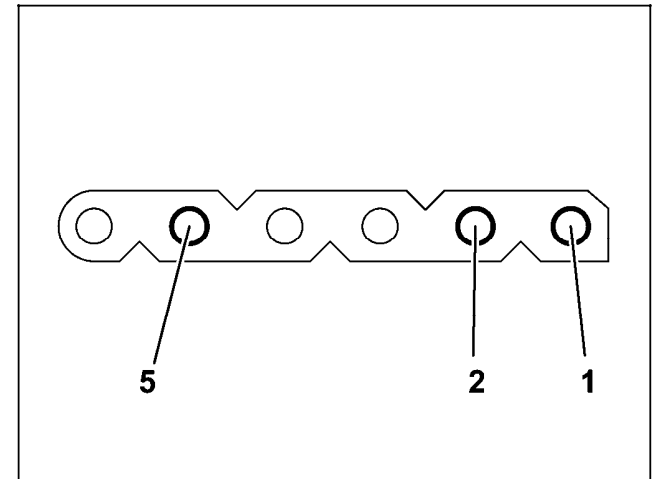

P80.50-2017-01

Electrical Test Program – Test – Connector Layouts

Connector Layout - Alarm siren with auxiliary battery (H3/1)

- 1 Voltage supply +
- 2 Ground
- 3 Data

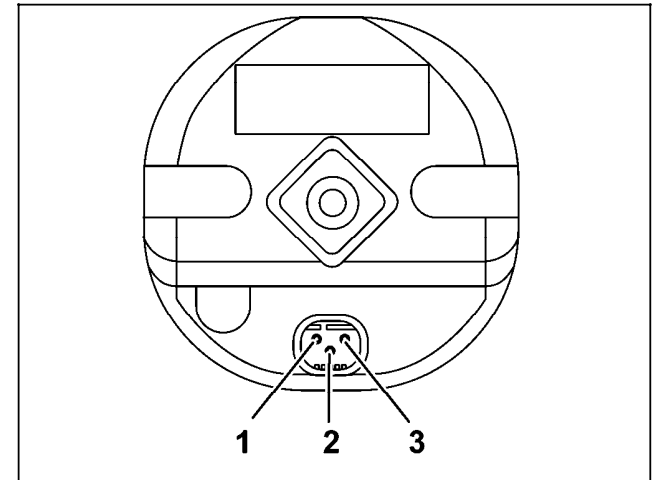

P80.50-2019-01