

Electrical Test Program – Preparation for Test

Preparation for Test:



The switches (left/right) for the front heated seats are integrated into the Front HS Control Module (N25/5). The control module can only be replaced as a complete unit.

1. Review section 0, 11, 14, 20, 22, 23
2. Battery voltage 11 – 14 V,
3. Check fuses ok.

Electrical wiring diagrams:

Electrical Troubleshooting Manual, Model 170, Volume 2, group 91,
Electrical Troubleshooting Manual, Model 202, Volume 2, group 91,
Electrical Troubleshooting Manual, Model 208, Volume 2, group 91,
Electrical Troubleshooting Manual, Model 210, Volume 2, group 91.

Special Tools

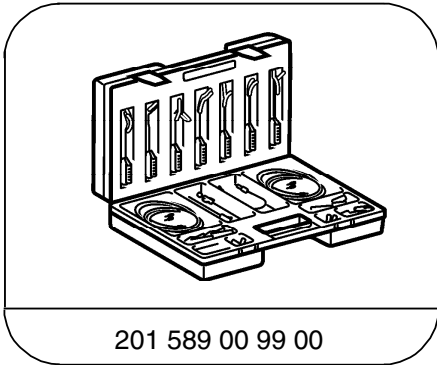

201 589 00 99 00

Electrical connecting set

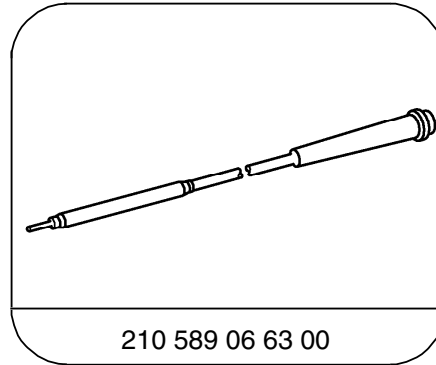

210 589 06 63 00

Adapter cable

Electrical Test Program – Preparation for Test**Conventional tools, test equipment**

Description	Brand, model, etc.
Multimeter ¹⁾	Fluke models 23, 83, 85, 87

¹⁾ Available through the MBUSA Standard Equipment Program.