

Electrical Test Program – Preparation for Test

Preparation for Test:

1. Review 20, 22, 23
2. Review components location: see GF91.30-P-3002-02GH
3. Review connector layout, see 23/9,
3. Fuses OK,
4. Battery voltage 11 – 14 V,
5. Convenience feature (CF) functional, see GF72.29-P-2002GH

Electrical wiring diagrams:

Electrical Troubleshooting Manual, Model 163,
(available in Work Shop Information System [WIS] only)

Special Tools

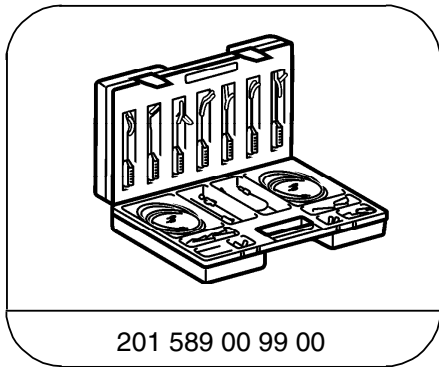

201 589 00 99 00

Electrical connecting set

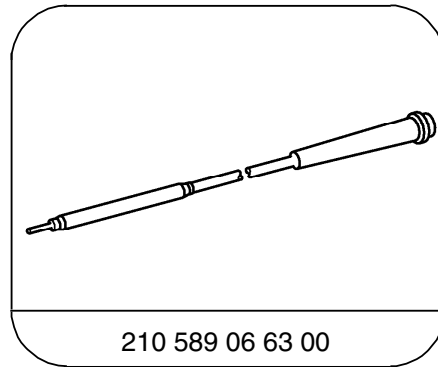

210 589 06 63 00

Adapter cable

Test equipment; See MBUSA Standard Service Equipment Program

Description	Brand, model, etc.
Digital multimeter	Fluke models 23, 77 III, 83, 85, 87