

12.2b Model 140

	Page
Diagnosis	
Function Test	11/1
Complaint Related Diagnostic Chart	12/1
Electrical Test Program	
Component Locations	21/1
Preparation for Test	22/1
Test	23/1

Diagnosis – Function Test

Component Locations

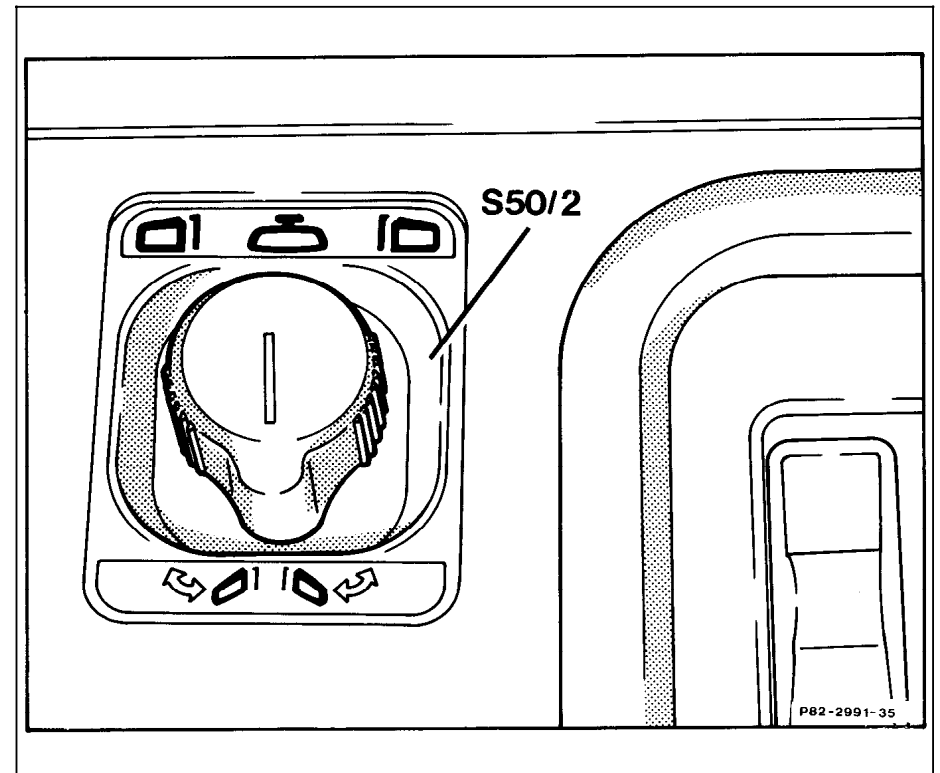

Figure 1

S50/2 Outside rearview mirror switch

P82-2991-35

Diagnosis – Function Test

Component Locations

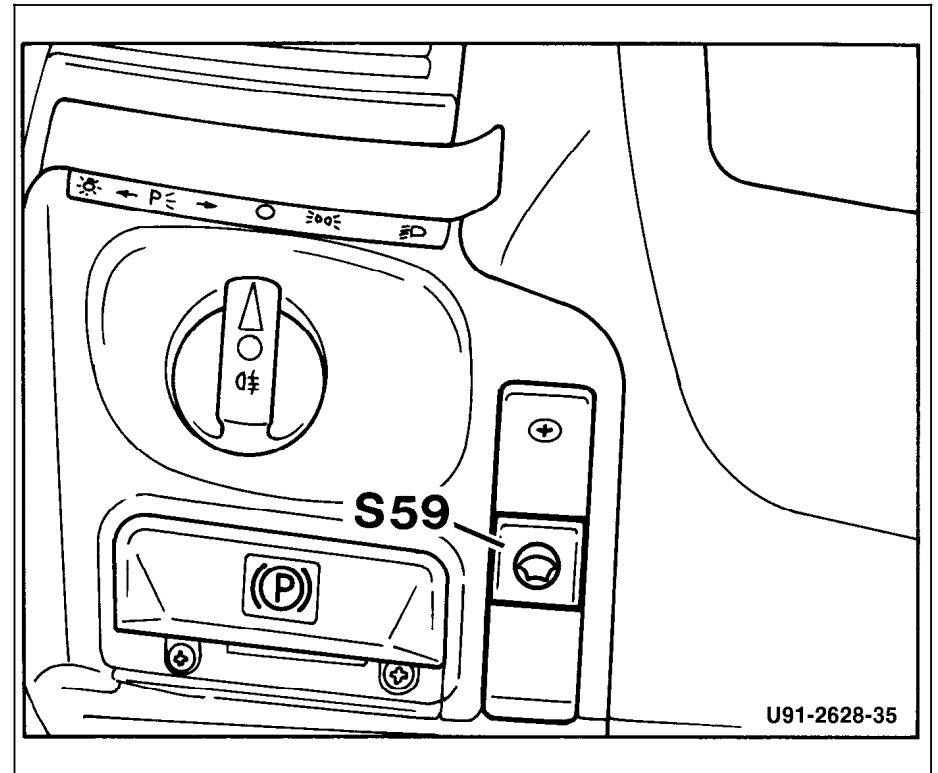

Figure 2

S59 Adjustable steering column switch

U91-2628-35

U91-2628-35

Diagnosis – Function Test

Test step/Test sequence	Test condition	Nominal value	Possible cause/Remedy ¹⁾
⇒ 1.0 Driver's side outside rearview mirror (M21/1) Adjust	Ignition: ON <i>or</i> Key in ignition Set mirror switch (S50/2) to driver's side mirror and adjust mirror	Adjust mirror: up down forward back	23 ⇒ 1.0 23 ⇒ 2.0
⇒ 2.0 Driver's side outside rearview mirror (M21/2) Adjust	Set mirror switch (S50/2) to passenger side mirror and adjust mirror	Adjust mirror: up down forward back	23 ⇒ 1.0 23 ⇒ 2.0
⇒ 3.0 Electrically adjustable inside rearview mirror (M21/3) Adjust	Set mirror switch (S50/2) to center position and adjust mirror	Adjust mirror: up down forward back	23 ⇒ 1.0 23 ⇒ 2.0

¹⁾ Observe Preparation for Test, see 22.

Diagnosis – Function Test

Test step/Test sequence	Test condition	Nominal value	Possible cause/Remedy ¹⁾
⇒ 4.0 Outside rearview mirror Retract	Set mirror switch (S50/2) to retract position and manipulate	Retract mirror Extend mirror	23 ⇒ 1.0 23 ⇒ 2.0 23 ⇒ 7.0
⇒ 5.0 Electrically adjustable steering column Adjust	Ignition: ON <i>or</i> Key in ignition Activate switch (S59)	Adjust steering column: up down forward back	23 ⇒ 1.0 23 ⇒ 3.0 23 ⇒ 8.0 23 ⇒ 9.0
⇒ 6.0 Automatic dimming inside rearview mirror (H7) Change reflection (dim)	Ignition: ON Cover forward light sensor (daylight) Shine a pocket lamp onto rear sensor (headlamp) Cover forward light sensor (daylight) and turn on dome lamp or engage transmission range “R”	Mirror reflection adjusts Mirror reflection adjusts Mirror reflection adjusts to normal position	23 ⇒ 17.0 23 ⇒ 18.0 23 ⇒ 19.0

1) Observe Preparation for Test, see 22.

Diagnosis – Complaint Related Diagnostic Chart

Complaint/Problem	Possible cause	Test step/Remedy ¹⁾
Electric mirrors and steering column adjustment does not function	Electric mirror/steering column adjustment control module (N32/9), voltage supply	23 ⇒ 1.0
Driver's side outside rearview mirror adjustment does not function	Electric mirror/steering column adjustment control module (N32/9) Outside rearview mirror control switch (S50/2) Electrically adjustable and heated driver's side outside rearview mirror (M21/1)	23 ⇒ 1.0 23 ⇒ 2.0 23 ⇒ 3.0
Passenger side outside rearview mirror adjustment does not function	Electric mirror/steering column adjustment control module (N32/9) Outside rearview mirror control switch (S50/2) Electrically adjustable and heated passenger side outside rearview mirror (M21/2)	23 ⇒ 1.0 23 ⇒ 2.0 23 ⇒ 5.0
Inside rearview mirror adjustment does not function	Electric mirror/steering column adjustment control module (N32/9) Outside rearview mirror control switch (S50/2) Left/right mirror retraction	23 ⇒ 1.0 23 ⇒ 2.0 23 ⇒ 6.0
	Driver's side outside rearview mirror, voltage supply	23 ⇒ 1.0
Passenger side outside rearview mirror heating does not function	Passenger side outside rearview mirror, voltage supply	12.2a 23

¹⁾ Observe Preparation for Test, see 22.

Diagnosis – Complaint Related Diagnostic Chart

Complaint/Problem	Possible cause	Test step/Remedy ¹⁾
Electric steering column adjustment does not function	Electric mirror/steering column adjustment control module (N32/9) Adjustable steering column switch (S59) Adjustable steering column motor (M20)	23 ⇒ 1.0 23 ⇒ 3.0 23 ⇒ 8.0, 9.0
Electric mirror and steering column adjustment memory does not function	Left front power seat control module (N32/1) and wiring Electrically adjustable and heated driver's side outside rearview mirror (M21/1), potentiometer Electrically adjustable and heated passenger side outside rearview mirror (M21/2), potentiometer Electrically adjustable inside rearview mirror (M21/3), potentiometer Adjustable steering column motor (M20), potentiometer	23 ⇒ 10.0 23 ⇒ 11.0 23 ⇒ 12.0 23 ⇒ 13.0 23 ⇒ 14.0
Outside rearview mirror control switch illumination does not function	Circuit 58d, voltage supply	23 ⇒ 15.0
Adjustable steering column switch illumination does not function	Circuit 58d, voltage supply	23 ⇒ 16.0
Automatic dimming inside rearview mirror does not function	Automatic dimming inside rearview (H7), voltage supply Backup lamp switch (S16/2) Dome lamp (E15) Automatic dimming inside rearview (H7)	23 ⇒ 17.0 23 ⇒ 18.0 23 ⇒ 19.0

¹⁾ Observe Preparation for Test, see 22.

Electrical Test Program – Component Locations

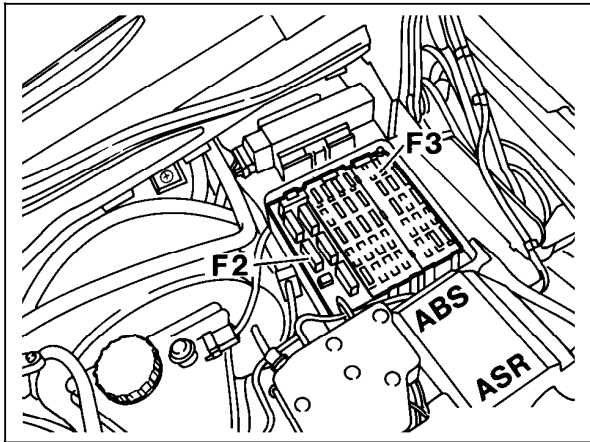

P54-2806-13

Figure 1

F3 Fuse box

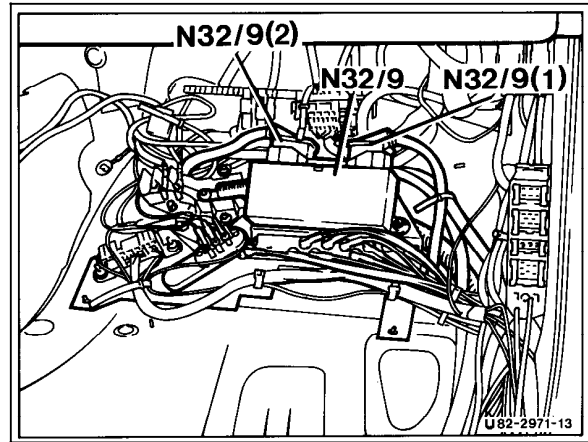

U82-2971-13

Figure 2

N32/9 Electrical mirror/steering column adjustment control module
 (1) Connector 1
 (2) Connector 2

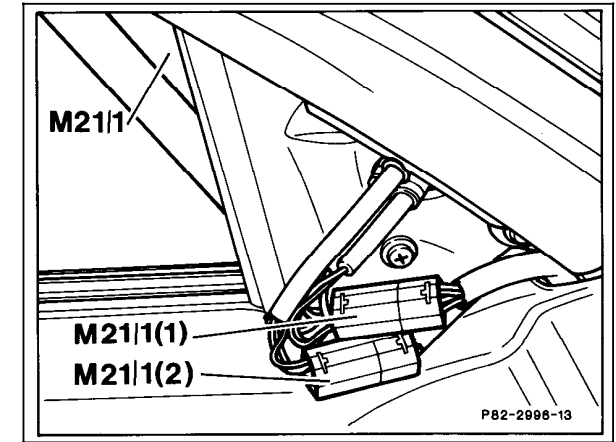

P82-2996-13

Figure 3

M21/1 Electrically adjustable and heated driver's side outside rearview mirror
 (1) Connector 1
 (2) Connector 2

Electrical Test Program – Component Locations

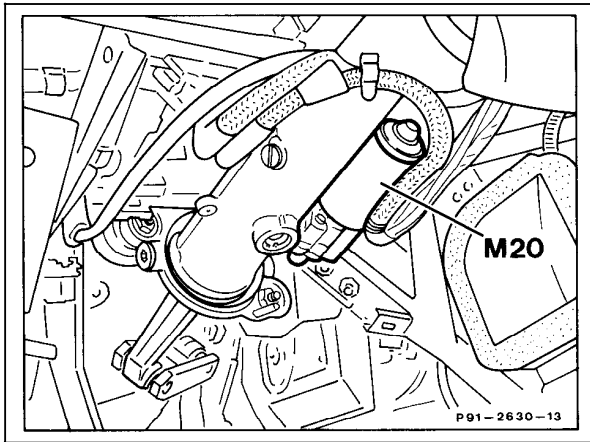

P91-2630-13

Figure 4

M20 Adjustable steering column motor

Electrical Test Program – Preparation for Test

1. Battery voltage 11–14 V.
2. Fuse F3-21, F3-24, F3-30 okay.
3. During voltage measurements, Ignition: ON

Electrical wiring diagrams:

Electrical Troubleshooting Manual, Model 140

Special Tools

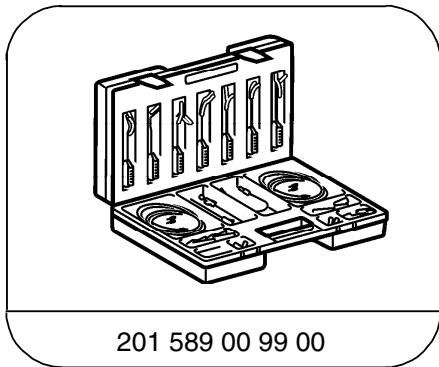

201 589 00 99 00

Electrical connecting set

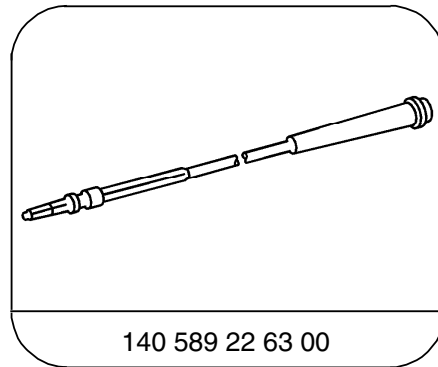

140 589 22 63 00

Adapter cable

Equipment

Digital multimeter ¹⁾

Fluke model 23 with 80i-410 current probe
Sun DMM-5

¹⁾ Available through the MBUSA Standard Equipment Program.

Electrical Test Program – Test

Test step DTC	Scope of test	Test connection	Test condition	Nominal value	Possible cause/remedy
⇒ 1.0	Electric mirror/steering column adjustment control module (N32/9) Voltage supply		Disconnect connector (2) from control module (N32/9)	11–14 V	Wiring
⇒ 2.0	Outside rearview mirror control switch (S50/2) Resistance	see Table I (23)	Disconnect connector (1) from control module (N32/9)	see Table I	Wiring Outside rearview mirror control switch (S50/2)
⇒ 3.0	Adjustable steering column switch (S59) Resistance	 	Disconnect connector (2) from control module (N32/9) Move mirror control switch (S59) forward Move switch (S59) back Move switch (S59) up Move switch (S59) down	 < 1 Ω < 1 Ω < 1 Ω < 1 Ω	Wiring Adjustable steering column switch (S59)

Electrical Test Program – Test

Test step DTC	Scope of test	Test connection	Test condition	Nominal value	Possible cause/remedy
⇒ 4.0	Electrically adjustable and heated passenger side outside rearview mirror (M21/2) Voltage supply	<p>M21/2 2 —(1) ←(V)→ —(1) 3</p>	Disconnect connector (1) from control module (M21/1) Mirror control switch (S50/2) in left position Move switch (S50/2): forward back	11–14 V -11 to -14 V	Wiring Electric mirror/steering column adjustment control module (N32/9)
		<p>M21/2 2 —(1) ←(V)→ —(1) 5</p>	Move switch (S50/2): left right	11–14 V -11 to -14 V	
⇒ 5.0	Electrically adjustable and heated driver's side outside rearview mirror (M21/2) Voltage supply	<p>M21/2 2 —(1) ←(V)→ —(1) 3</p>	Disconnect connector (1) from control module (M21/2) Mirror control switch (S50/2) in right position Move switch (S50/2): forward back	11–14 V -11 to -14 V	Wiring Electric mirror/steering column adjustment control module (N32/9)
		<p>M21/2 2 —(1) ←(V)→ —(1) 5</p>	Move switch (S50/2): right left	11–14 V -11 to -14 V	

Electrical Test Program – Test

Test step DTC	Scope of test	Test connection	Test condition	Nominal value	Possible cause/remedy
⇒ 6.0	Electrically adjustable inside rearview mirror (M21/3) Voltage supply	<p>M21/3 5 —(←(V)→)— 6</p> <p>M21/3 7 —(←(V)→)— 5</p>	<p>Remove inside mirror (M21/3) and disconnect connector</p> <p>Mirror control switch (S50/2) in center position</p> <p>Move switch (S50/2): forward back</p> <p>Move switch (S50/2): left right</p>	<p>11–14 V -11 to -14 V</p> <p>11–14 V -11 to -14 V</p>	<p>Wiring</p> <p>Electric mirror/steering column adjustment control module (N32/9)</p>
⇒ 7.0	Electrically adjustable outside rearview mirrors (M21/1, M21/2), retraction feature Voltage supply	<p>M21/1, M21/2 7 —(←(V)→)— 6</p>	<p>Disconnect connector (X54/7)</p> <p>Move switch (S50/2): forward back</p>	<p>11–14 V -11 to -14 V</p>	<p>Wiring</p> <p>Electric mirror/steering column adjustment control module (N32/9)</p>

Electrical Test Program – Test





Test step DTC	Scope of test	Test connection	Test condition	Nominal value	Possible cause/remedy
⇒ 8.0	Adjustable steering column motor (M20) Voltage supply	<p>X54/7 2 —(←(V)→)— 1</p> <p>X54/7 7 —(←(V)→)— 8</p>	<p>Disconnect connector (X54/7)</p> <p>Move steering column switch (S59): right left</p> <p>Move switch (S50): forward back</p>	<p>11–14 V -11 to -14 V</p> <p>11–14 V -11 to -14 V</p>	<p>Wiring</p> <p>Electric mirror/steering column adjustment control module (N32/9)</p>
⇒ 9.0	Adjustable steering column motor (M20) Voltage supply	<p>X54/7 1 v ←(Ω)→ — 2</p> <p>X54/7 7 v ←(Ω)→ — 8</p>	<p>Disconnect connector (X54/7)</p>	<p>0.1–15 Ω</p> <p>0.1–15 Ω</p>	<p>Wiring</p> <p>Adjustable steering column motor (M20)</p>

Electrical Test Program – Test

Test step DTC	Scope of test	Test connection	Test condition	Nominal value	Possible cause/remedy
⇒ 10.0	Serial Data Exchange ¹⁾ from Left front power seat control module (N32/1) to Electric mirror/steering column adjustment control module (N32/9)	<p>N32/9 2 (1)</p>	Disconnect connector (1) from control module (N32/9) Press one of the memory position buttons on left front power seat switch group (S91)	0–1 V 4–7 V	Wiring Left front power seat control module (N32/1)
⇒ 11.0	Electrically adjustable and heated driver’s side outside rearview mirror (M21/1) Potentiometer resistance	<p>N32/9 21 (1) 4 (1)</p> <p>N32/9 1 (1) 8 (1)</p>	Disconnect connector (1) from control module (N32/9) Manually move mirror glass in all directions	approx. 1000 Ω value changes from 300–1200 Ω	Wiring Electrically adjustable and heated driver’s side outside rearview mirror (M21/1)

¹⁾ Serial Data Exchange=data cable over which digital data is transmitted in sequence.

Electrical Test Program – Test

Test step DTC	Scope of test	Test connection	Test condition	Nominal value	Possible cause/remedy
⇒ 12.0	Electrically adjustable and heated passenger side outside rearview mirror (M21/2) Potentiometer resistance	N32/9 14 —(←  →)— 19 (1) (1)	Disconnect connector (1) from control module (N32/9)	approx. 1000 Ω	Wiring Electrically adjustable and heated passenger side outside rearview mirror (M21/2)
		N32/9 9 —(←  →)— 16 (1) (1)	Manually move mirror glass in all directions	value changes from 300–1200 Ω	
⇒ 13.0	Electrically adjustable inside rearview mirror (M21/3) Potentiometer resistance	N32/9 6 —(←  →)— 7 (2) (2)	Disconnect connector (2) from control module (N32/9)	approx. 1200 Ω	Wiring Electrically adjustable inside rearview mirror (M21/3)
		N32/9 18 —(←  →)— 19 (2) (2)	Manually move mirror glass in all directions	value changes from 400–1300 Ω	
⇒ 14.0	Adjustable steering column motor (M20) Potentiometer resistance	N32/9 6 —(←  →)— 13 (2) (2)	Disconnect connector (2) from control module (N32/9)	1100±220 Ω	Wiring Adjustable steering column motor (M20) ⇒ 14.1

Electrical Test Program – Test

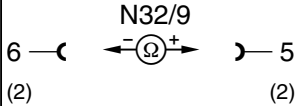
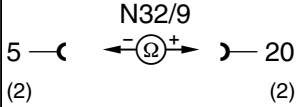
Test step DTC	Scope of test	Test connection	Test condition	Nominal value	Possible cause/remedy
⇒ 14.1	Potentiometer resistance		<p>Connect connector (2) to control module (N32/9) Adjust steering column through complete range: up/back/down/forward</p> <p>Disconnect connector (2) from control module (N32/9)</p>	record value	Wiring Adjustable steering column motor (M20) ⇒ 14.2
			<p>Connect connector (2) to control module (N32/9) Adjust steering column to full rear stop</p> <p>Disconnect connector (2) from control module (N32/9)</p>	600±300 Ω difference from recorded value	

Electrical Test Program – Test

Test step DTC	Scope of test	Test connection	Test condition	Nominal value	Possible cause/remedy
⇒ 14.2	Potentiometer resistance	<p style="text-align: center;">N32/9</p> <p>6 —(← ⊖ Ω ⊕ →)— 20 (2) (2)</p>	<p>Disconnect connector (2) from control module (N32/9)</p> <p>Connect connector (2) to control module (N32/9) Adjust steering column to full up stop</p>	<p>record value</p> <p>600±300 Ω difference from recorded value</p>	<p>Wiring</p> <p>Adjustable steering column motor (M20)</p>
⇒ 15.0	<p>Outside rearview mirror switch (S50/2)</p> <p>Voltage supply</p>	<p style="text-align: center;">S50/2</p> <p>3 —(← ⊖ V ⊕ →)— 2</p>	<p>Disconnect connector from switch (S50/2)</p> <p>Parking lamps ON</p>	11–14 V	<p>Wiring</p> <p>Outside rearview mirror switch (S50/2)</p>

Electrical Test Program – Test

Test step DTC	Scope of test	Test connection	Test condition	Nominal value	Possible cause/remedy
⇒ 16.0	Adjustable steering column switch (S59) Voltage supply	7 —(←(V)→)— 5 S59	Disconnect switch (S59) Parking lamps ON	11–14 V	Voltage supply, circuit 58d Adjustable steering column switch (S59)
⇒ 17.0	Automatic dimming inside rearview mirror (H7) Voltage supply	2 —(←(V)→)— 5 H7	Disconnect connector from mirror (H7) Ignition: ON	11–14 V	Wiring
⇒ 18.0	Backup lamp switch (S16/2) Voltage supply	2 —(←(V)→)— 1 H7	Disconnect connector from mirror (H7) Ignition: ON Transmission range “R” engaged	0–1 V 11–14 V	Wiring Backup lamp switch (S16/2) Exterior lamp failure monitoring module (N7)
⇒ 19.0	Dome lamp (E15) Voltage supply	3 —(←(V)→)— 5 H7	Disconnect connector from mirror (H7) Ignition: ON Dome lamp: ON	0–5 V 11–14 V	Wiring Dome lamp (E15)

Electrical Test Program – Test

Switch (S50/2) setting	Move switch	1) \perp $\leftarrow \ominus^+ \rightarrow$ \curvearrowright 10	\perp $\leftarrow \ominus^+ \rightarrow$ \curvearrowright 11	\perp $\leftarrow \ominus^+ \rightarrow$ \curvearrowright 17	\perp $\leftarrow \ominus^+ \rightarrow$ \curvearrowright 18
Center (inside mirror)	to the: left right forward back	< 1 Ω < 1 Ω < 1 Ω < 1 Ω	> 20 k Ω > 20 k Ω > 20 k Ω > 20 k Ω	> 20 k Ω < 1 Ω < 1 Ω > 20 k Ω	> 20 k Ω > 20 k Ω < 1 Ω < 1 Ω
Left (Driver side mirror)	to the: left right forward back	< 1 Ω < 1 Ω < 1 Ω < 1 Ω	< 1 Ω < 1 Ω < 1 Ω < 1 Ω	> 20 k Ω < 1 Ω < 1 Ω > 20 k Ω	> 20 k Ω > 20 k Ω < 1 Ω < 1 Ω
Right (Passenger side)	to the: left right forward back	> 20 k Ω > 20 k Ω > 20 k Ω > 20 k Ω	< 1 Ω < 1 Ω < 1 Ω < 1 Ω	> 20 k Ω < 1 Ω < 1 Ω > 20 k Ω	> 20 k Ω > 20 k Ω < 1 Ω < 1 Ω
Retract (mirrors fold-in)	to the: forward back	> 20 k Ω > 20 k Ω	< 20 k Ω < 20 k Ω	< 1 Ω > 20 k Ω	< 1 Ω < 1 Ω

1) Disconnect connector (1) from Control module (N32/9)

Electrical Test Program – Test

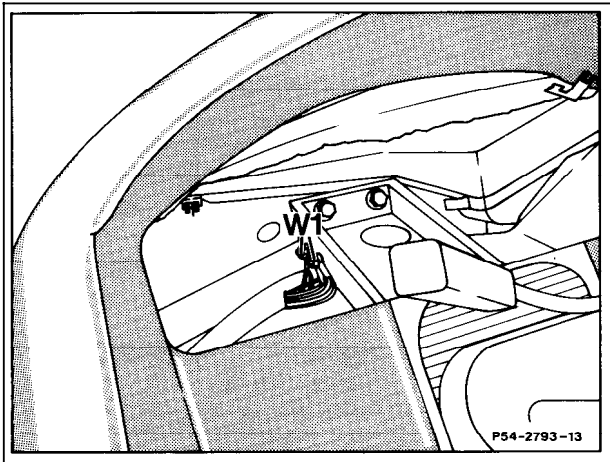

Figure 1
W1 Main ground (behind instrument cluster)

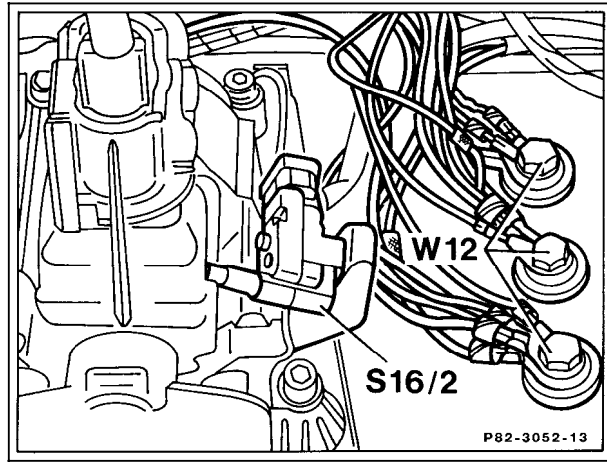

Figure 2
W12 Ground (center console)

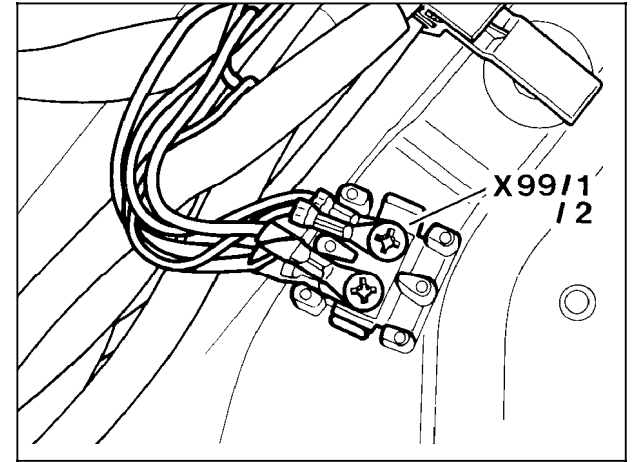

Figure 3
X99/1 Engine/chassis harness connector

Electrical Test Program – Test

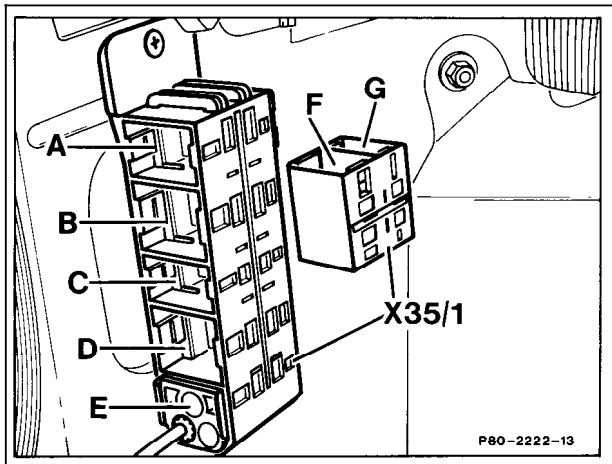

Figure 4
X35/1 Left front door plug connection

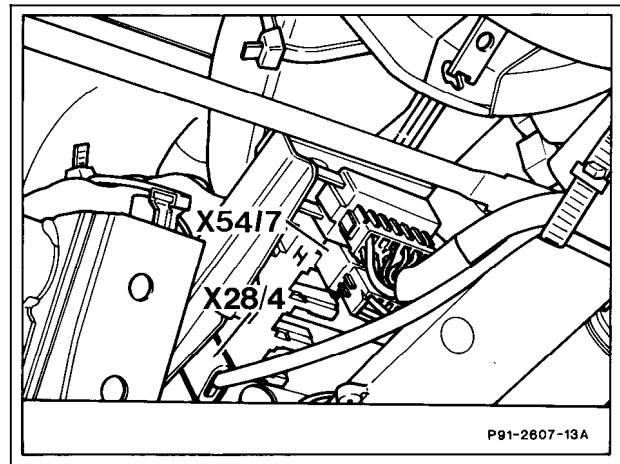

Figure 5
X54/7 Adjustable steering column control module/motor connector