

16.1 Models 124 (as of 09/87), 129, 201 (from 09/87 to 06/93 production)

	Page
Diagnosis (driver-side or driver/passenger-side airbag)	
Function Test	11/1
Diagnostic Trouble Code (DTC) Memory	12/1
Complaint Related Diagnostic Chart	13/1
Electrical Test Program (driver-side or driver/passenger-side airbag)	
Component Locations	21/1
Preparation for Test	22/1
Test	23/1
Electrical Test Program (Emergency Tensioning Retractors - ETR's)	
Preparation for Test	31/1
Test	32/1
Electrical Test Program (test if there is no DTC)	
Test	33/1

Diagnosis - Function Test (driver-side or driver/passenger-side airbag)**⚠ CAUTION!**

Risk of Injury when performing Diagnostic Tests and repairs on components of the SRS system.

Store both airbags and side airbags with opening surface pointing upward.

Do not expose to temperatures above 100°C.

Interrupt any electrical current from reaching the airbag unit.

⚠ CAUTION!

Risk of injury if airbag units and ETR units are ignited accidentally or if stored with the opening end facing downward which may cause the accidentally ignited components to fly about causing injury. Danger to persons also exists if the components are disposed of by cutting apart with cutting torches or other cutting/separation devices. Danger also exists if disposing the untriggered units via refuse collection or via smelting/carbonizing companies.

Protective measures/Supervision

- Place removed airbag unit with the opening side facing upward.
- Allow only **properly trained dealer staff** to supervise, purchase, transport, store, test/replace any of the SRS components.
- Install all airbag or ETR units once pulled from the parts department.
- Protect all airbag or ETR units from any sparks, open flame, or temperatures above 100°C.
- Do not transport airbag or ETR units in the passenger compartment, rather transport securely in their **original packaging** in the trunk.
- Do not allow oil, grease or cleaning agents come in contact with the airbag or ETR units
- Perform SRS tests only with approved test equipment (such as HHT), while installed in the vehicle **without** occupants.

- When reconnecting the vehicle battery or any outside electrical source, with the ignition turned ON, do not allow any occupants inside the vehicle.
- Airbag or ETR units which have been dropped from a height greater than 18 inches must be replaced.
- Prior to disposing the airbag or ETR units, the units must be made un-useable by discharging.
- In order to render the airbag and ETR unit un-useable, the specially made discharge harness must be used and at the same time maintain a **safe distance of at least 33 feet** from the units being discharged.

Prior to undertaking any chassis/body repairs, installation/repair work on airbag and ETR units, or any components which come in contact with the airbag and ETR units, or are part of the electrical circuit of airbag and ETR units (such as installation of the steering wheel), the following conditions must be met:

- Remove ignition key.
- Disconnect any outside source of electrical circuit (i.e. battery charger).
- When performing interior repairs or welding operations, disconnect the connector from the SRS control module.

Diagnosis - Function Test (driver-side or driver/passenger-side airbag)

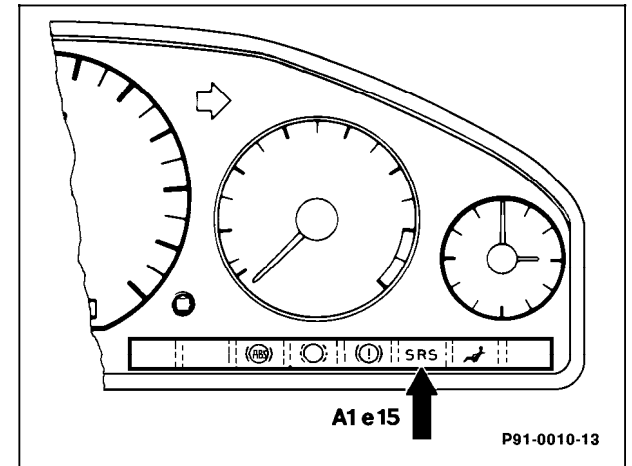


Figure 1
A1e15 SRS malfunction indicator lamp

P91-0010-13

Test step/Test sequence	Test condition	Nominal value	Possible cause/Remedy ¹⁾
⇒ 1.0 Supplemental Restraint System	Ignition key in position "1"	SRS malfunction indicator lamp (A1e15) comes on for approximately 4 seconds	12 DTC Memory

¹⁾ Observe Preparation for Test, see 22.

Diagnosis - Diagnostic Trouble Code (DTC) Memory (driver-side or driver/passenger-side airbag)

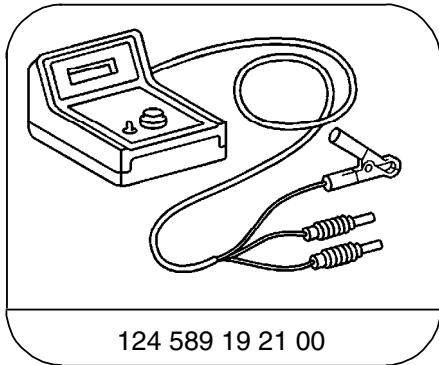
Preliminary work:

Diagnosis - Function Test 11

Preparation for DTC readout

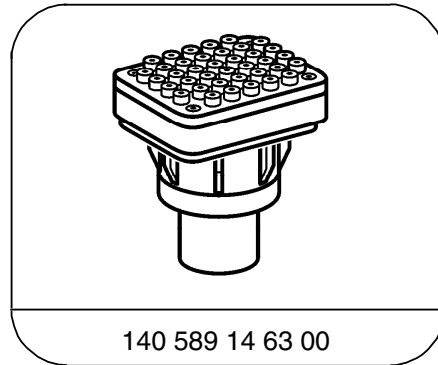
- Fuses O.K.
- Connect impulse counter scan tool to data link connector (X11/4) according to connection diagram (see section 0).
 - 8- or 16-pole connector: yellow wire to socket 6
 - 38-pole connector: yellow wire to socket 30
- The 10-pole SRS test connection (X11/13) must be connected for DTC.

Special Tools



124 589 19 21 00

Pulse counter



140 589 14 63 00

Adapter

Diagnosis - Diagnostic Trouble Code (DTC) Memory (driver-side or driver/passenger-side airbag)

Diagnostic trouble code (DTC) 8	Possible cause	Test step/Remedy 1)
1	No fault recognized in system	–
2	SRS control module (N2/2)	23 ⇒ 2.0
3	Driver airbag squib (R12/3)	23 ⇒ 3.0, 9.0
4	Front passenger airbag squibs (R12/4, R12/5)	23 ⇒ 4.0, 10.0
5	Left front seat belt buckle switch (S68/3)	23 ⇒ 5.0
6	Right front seat belt buckle switch (S68/4)	23 ⇒ 6.0
7	Front passenger airbag resistance	23 ⇒ 7.0
8	Voltage supply circuit 15R	23 ⇒ 1.0
9	SRS malfunction indicator lamp (A1e15) or time limit for DTC readout /erasing exceeded	23 ⇒ 8.0
10 2)	SRS control module (N2/2)	N2/2 (SMS, Job No. 91-620)

1) Observe Preparation for Test, see 22.

2) DTC 10 indicates that the airbag deployment stage was activated in the control module. This DTC can not be erased. **The control module must be replaced.**

**IMPORTANT NOTE!**

Before replacing the SRS control module (N2/2) in cases of DTC 10 without an airbag deployment, reposition airbag harness ground connections to lowest terminal connection.

Note:

The ETR's are not included in the DTC readout, if DTC 3 and/or 4 can not be erased, see ETR Test 32 ⇒ 1.0 and 2.0 1).

Diagnosis - Complaint Related Diagnostic Chart (driver-side or driver/passenger-side airbag)

Complaint/Problem	Possible cause	Test step/Remedy ¹⁾
SRS malfunction indicator lamp (A1e15) does not come on with ignition key in position "1", does not go out after approximately 4 seconds, flickers or comes on while driving.	-	12 DTC Memory

¹⁾ Observe Preparation for Test, see 22.

Electrical Test Program - Component Locations (driver-side or driver/passenger-side airbag)

Model 124 Driver/passenger-side airbag

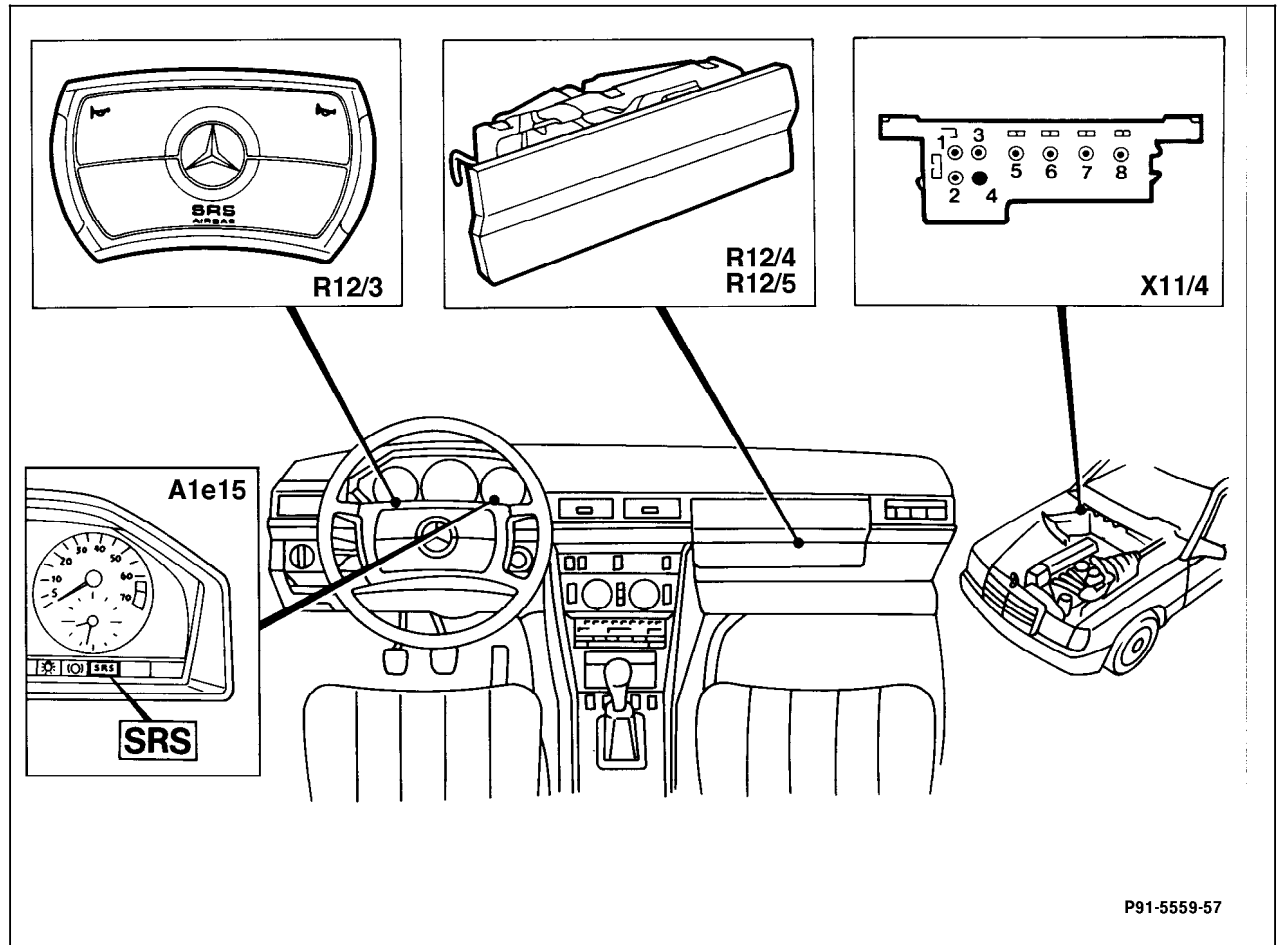


Figure 1

- A1e15 Supplemental restraint system malfunction indicator lamp
- R12/3 Driver airbag squib
- R12/4 Front passenger airbag squib 1
- R12/5 Front passenger airbag squib 2
- X11/4 Data link connector (DTC readout)

P91-5559-57

P91-5559-57

Electrical Test Program - Component Locations (driver-side or driver/passenger-side airbag)

Model 124 Driver/passenger-side airbag

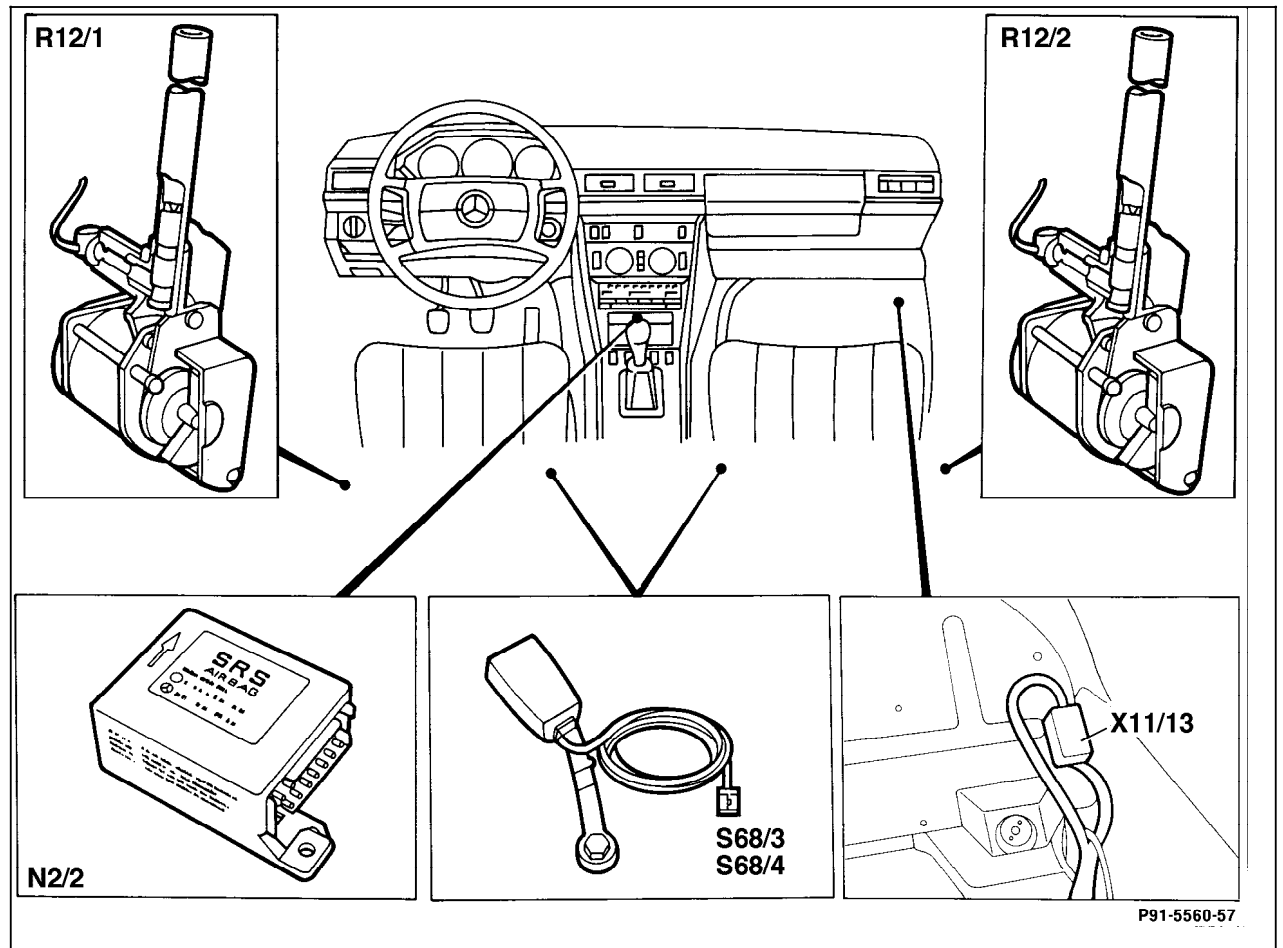


Figure 2

- N2/2 Supplemental restraint system control module
- R12/1 Left front emergency tensioning retractor squib
- R12/2 Right front emergency tensioning retractor squib
- S68/3 Left front seat belt buckle switch (airbag/ETR)
- S68/4 Right front seat belt buckle switch (airbag/ETR)
- X11/13 SRS test connection (10-pole)

P91-5560-57

P91-5560-57

Electrical Test Program - Component Locations (driver-side or driver/passenger-side airbag)

Model 129 Driver/passenger-side airbag

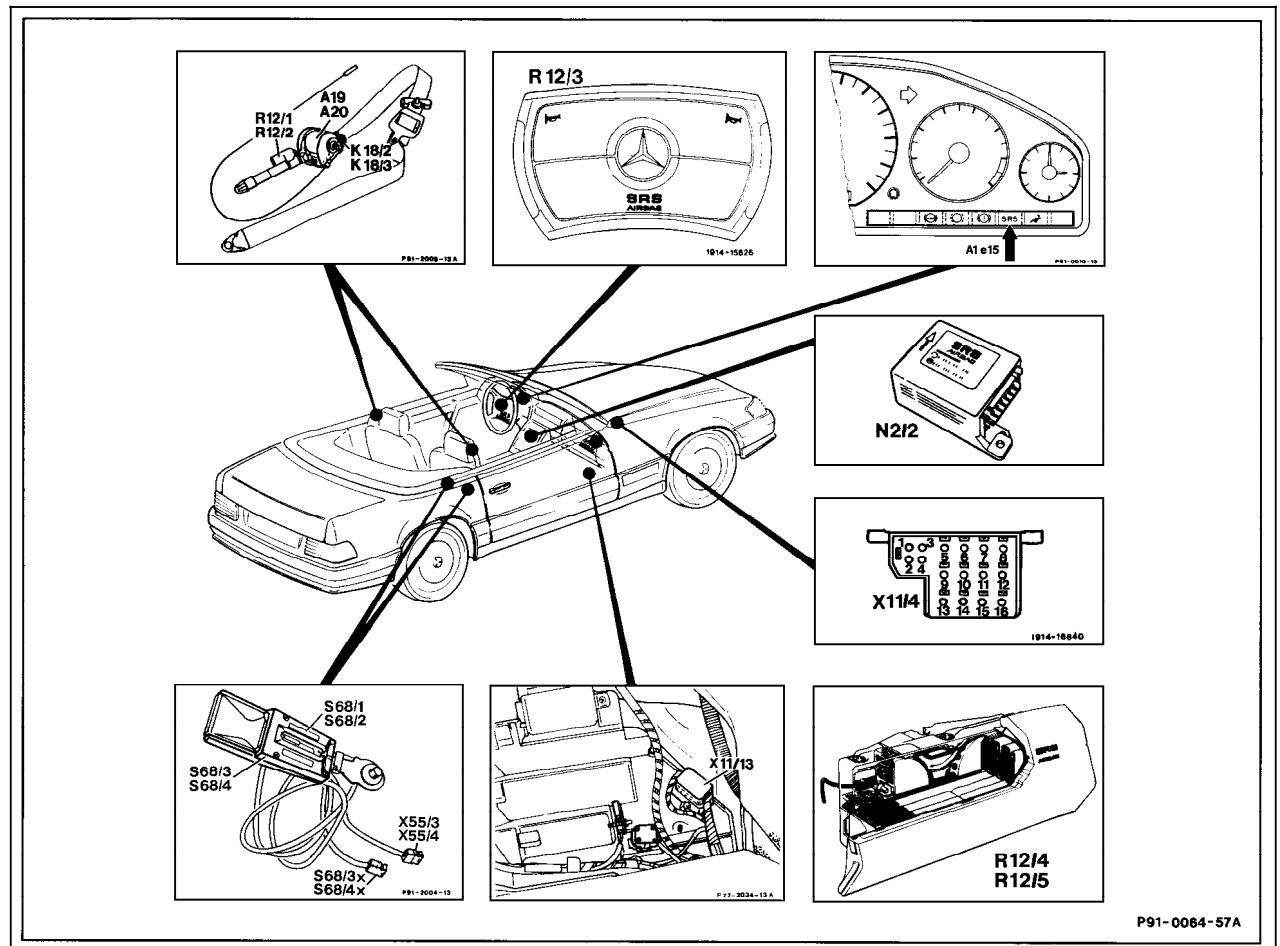


Figure 3

- A1e15 Supplemental restraint system malfunction indicator lamp
- N2/2 Supplemental restraint system control module
- R12/1 Left front emergency tensioning retractor squib
- R12/2 Right front emergency tensioning retractor squib
- R12/3 Driver airbag squib
- R12/4 Front passenger airbag squib 1
- R12/5 Front passenger airbag squib 2
- S68/3 Left front seat belt buckle switch (airbag/ETR)
- S68/4 Right front seat belt buckle switch (airbag/ETR)
- X11/4 Data link connector (DTC readout)
- X11/13 SRS test connection (10-pole)
- X55/3 Left seat contact strip
- X55/4 Right seat contact strip

P91-0064-57A

P91-0064-57A

Electrical Test Program - Component Locations (driver-side or driver/passenger-side airbag)

Model 201 Driver-side airbag

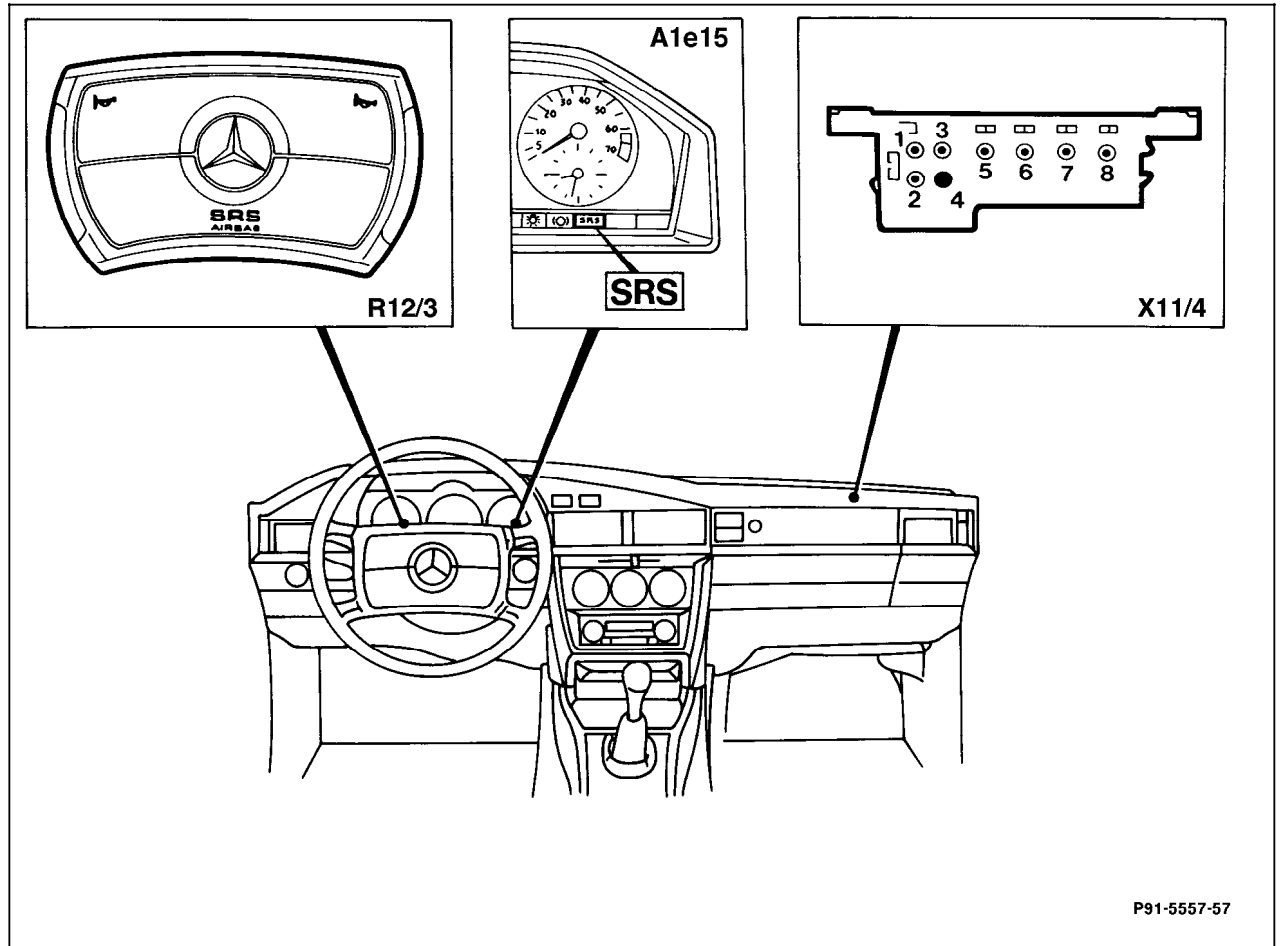


Figure 4

- A1e15 Supplemental restraint system malfunction indicator lamp
- R12/3 Driver airbag squib
- X11/4 Data link connector (DTC readout)

P91-5557-57

P91-5557-57

Electrical Test Program - Component Locations (driver-side or driver/passenger-side airbag)

Model 201 Driver-side airbag

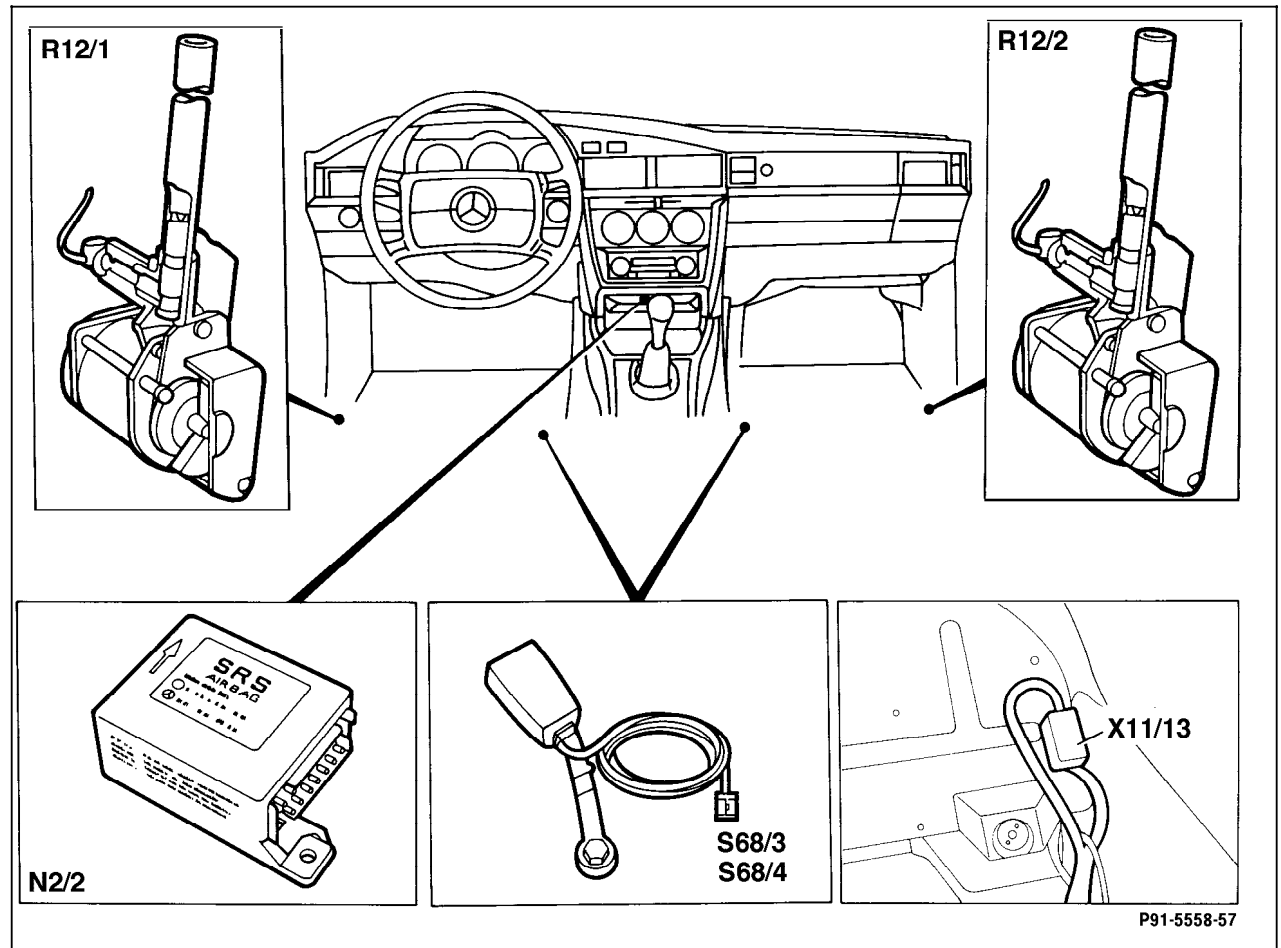


Figure 5

- N2/2 SRS control module
- R12/1 Left front ETR squib
- R12/2 Right front ETR squib
- S68/3 Left front seat belt buckle switch (airbag/ETR)
- S68/4 Right front seat belt buckle switch (airbag/ETR)
- X11/13 ETR test connection

P91-5558-57

P91-5558-57

Electrical Test Program - Preparation for Test (driver-side or driver/passenger-side airbag)

Preliminary work:

Diagnosis - Diagnostic Trouble Code (DTC) Memory 12

1. Battery voltage 11–14 V.
2. SRS malfunction indicator lamp (A1e15) comes on.
3. Ignition: **OFF**, disconnect and cover battery negative terminal.
4. Disconnect SRS test connection (X11/13).
5. Connect socket box and test cable according to connection diagram (Figure 1).

Electrical wiring diagrams :

Electrical Troubleshooting Manual, Models 124 and 201, Starting M.Y. 1984

Electrical Troubleshooting Manual, Model 124, Starting M.Y. 1993

Electrical Troubleshooting Manual, Model 129.

WARNING!

Do not connect battery charger.

Note concerning Test Connection column in 23:

example

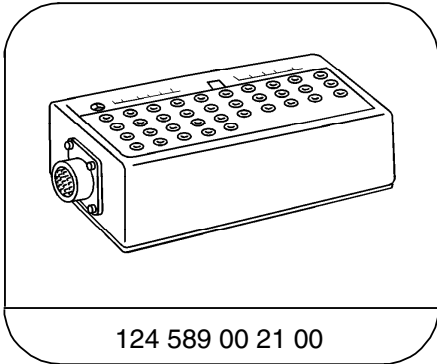
23 ⇒ 5.0 (D.1)

D= connector

1=socket 1

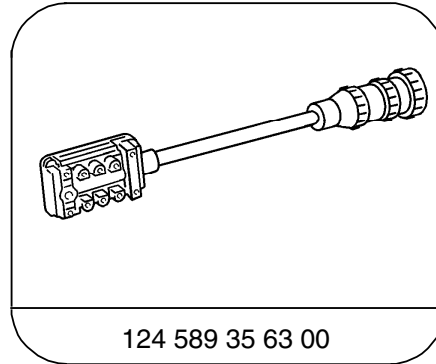
Electrical Test Program - Preparation for Test (driver-side or driver/passenger-side airbag)

Special Tools



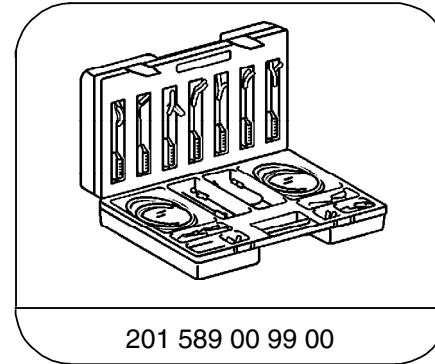
124 589 00 21 00

35-pin socket box



124 589 35 63 00

Test cable



201 589 00 99 00

Electrical connecting set

Equipment

Digital multimeter ¹⁾

Fluke 23, 83, 88
Sun DMM-5

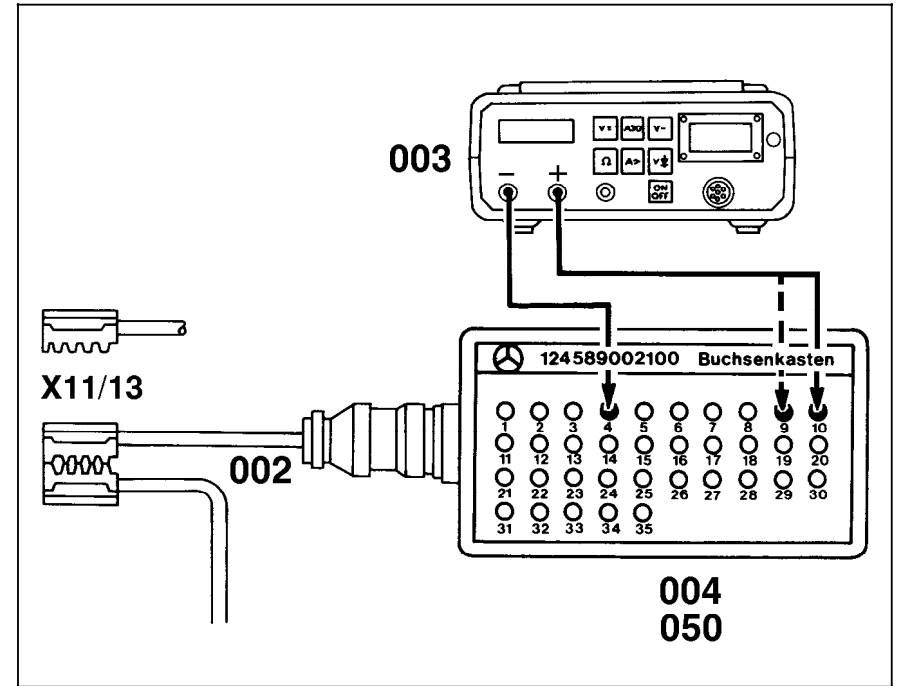
¹⁾ Available through the MBUSA Standard Equipment Program.

Electrical Test Program - Preparation for Test (driver-side or driver/passenger-side airbag)

Connection Diagram - Digital Multimeter and Socket Box Tester



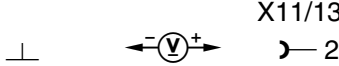





Figure 1

- 002 Test cable 124 589 35 63 00
- 003 Digital multimeter
- 004 Socket box
- 050 Socket box
- X11/13 SRS test connection (10-pole)







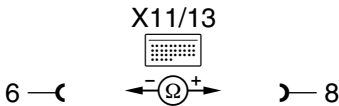
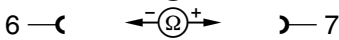


P91-5563-35


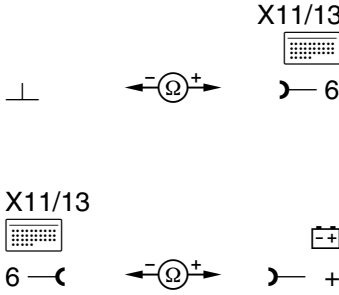
Electrical Test Program - Test (driver-side or driver/passenger-side airbag)

⇒		Test scope	Test connection	Test condition	Nominal value	Possible cause/Remedy
1.0		Voltage supply Circuit 15R		Ignition: OFF Disconnect and cover battery negative terminal. Disconnect SRS test connection (X11/13). Ignition key in position "1".	11–14 V	Wiring.
2.0		SRS control module (N2/2)		Ignition: ON Erase DTC 	DTC  erased.	SRS control module (N2/2), (SMS, Job No. 91-620).
3.0		Driver airbag squib (R12/3)		Ignition: OFF Disconnect and cover battery negative terminal. Disconnect SRS test connection (X11/13). Connect test cable according to connection diagram. Turn steering wheel from full right to full left stop.	2–5 Ω	Wiring, < 2 Ω short circuit, > 5 Ω open circuit, Slip rings, 4-part carbon contact for slip rings, Driver airbag (SMS, Job No. 91-660) ⇒ 3.1


Electrical Test Program - Test (driver-side or driver/passenger-side airbag)

⇒		Test scope	Test connection	Test condition	Nominal value	Possible cause/Remedy
3.1		Isolation resistance	 		<p>> 20 kΩ</p> <p>> 20 kΩ</p>	<p>Wiring, Short circuit to circuit 31.</p> <p>Wiring, Short circuit to circuits 15/15R/30, If nominal values are obtained but DTC  can not be erased, 32 ⇒ 1.0, 2.0 23 ⇒ 9.0</p>
4.0		Front passenger airbag squib 1 (R12/4), squib 2 (R12/5)	 	<p>Ignition: OFF</p> <p>Disconnect and cover battery negative terminal.</p> <p>Disconnect SRS test connection (X11/13).</p> <p>Connect test cable according to connection diagram.</p>	<p>2-5 Ω</p>	<p>< 2 Ω short circuit, > 5 Ω open circuit, Passenger side airbag, ⇒ 4.1</p>



Electrical Test Program - Test (driver-side or driver/passenger-side airbag)

⇒		Test scope	Test connection	Test condition	Nominal value	Possible cause/Remedy
4.1	4	Isolation resistance	 <p>X11/13 6</p> <p>X11/13 6</p> <p>X11/13 +</p>		<p>> 20 kΩ</p> <p>> 20 kΩ</p>	<p>Wiring, Short circuit to circuit 31.</p> <p>Wiring, Short circuit to circuits 15/15R/30, If nominal values are obtained but DTC 4 can not be erased, 32 ⇒ 1.0, 2.0 23 ⇒ 10.0</p>


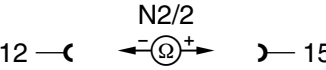
Electrical Test Program - Test (driver-side or driver/passenger-side airbag)

⇒		Test scope	Test connection	Test condition	Nominal value	Possible cause/Remedy
5.0	5	Left front seat belt buckle switch (S68/3)	<p style="text-align: center;">S68/3x1</p> <p style="text-align: center;">← ⊖ ⊕ →</p> <p>2 ——— 1</p>	<p>Ignition: OFF</p> <p>Models 124, 201 Disconnect switch connector (S68/3x1). Seat belt tongue in buckle: Not latched</p> <p>Latched</p> <p>Model 129 Disconnect left seat contact strip (X55/3). Seat belt tongue in buckle: Not latched</p> <p>Latched</p>	<p>400 Ω±10 Ω</p> <p>100 Ω±10 Ω</p> <p>400 Ω±10 Ω</p> <p>100 Ω±10 Ω</p>	<p>Wiring, open circuit, Short circuit or shorted to circuit 31, Ground (W26), Seat belt buckle (SMS, Job No. 91-502).</p>
			<p style="text-align: center;">X55/3</p> <p style="text-align: center;">← ⊖ ⊕ →</p> <p>2 ——— 1</p> <p>(D.1) (D.1)</p>			


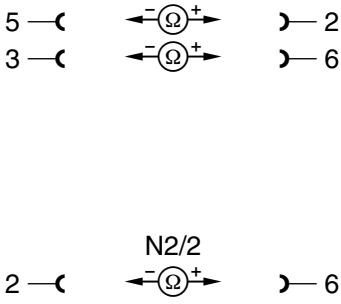
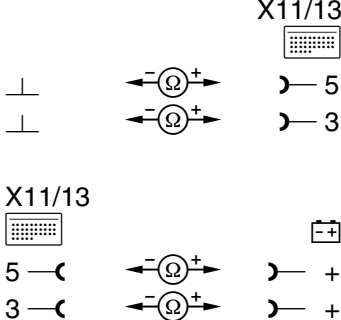
Electrical Test Program - Test (driver-side or driver/passenger-side airbag)

⇒		Test scope	Test connection	Test condition	Nominal value	Possible cause/Remedy
6.0		Right front seat belt buckle switch (S68/4)	<p style="text-align: center;">S68/4x1</p> <p style="text-align: center;">← ⊖ ⊕ →</p> <p>2 ——— 1</p>	<p>Ignition: OFF</p> <p>Models 124, 201 Disconnect switch connector (S68/4x1). Seat belt tongue in buckle: Not latched</p> <p>Latched</p> <p>Model 129 Disconnect left seat contact strip (X55/4). Seat belt tongue in buckle: Not latched</p> <p>Latched</p>	<p>400 Ω±10 Ω</p> <p>100 Ω±10 Ω</p> <p>400 Ω±10 Ω</p> <p>100 Ω±10 Ω</p>	<p>Wiring, open circuit, Short circuit or shorted to circuit 31, Ground (W26), Seat belt buckle (SMS, Job No. 91-502).</p>
			<p style="text-align: center;">X55/4</p> <p style="text-align: center;">← ⊖ ⊕ →</p> <p>2 ——— 1</p> <p>(D.1) (D.1)</p>			
















Electrical Test Program - Test (driver-side or driver/passenger-side airbag)

⇒		Test scope	Test connection	Test condition	Nominal value	Possible cause/Remedy
7.0	7	Front passenger airbag Resistance		Ignition: OFF Disconnect and cover battery negative terminal. Disconnect SRS test connection (X11/13). Disconnect control module (N2/2) connector.	100 Ω	Wiring, Ground (W26), Resistance in connector to control module (N2/2).
8.0	9	SRS MIL (A1e15)		Ignition key in position "1"	SRS MIL (A1e15) comes on and then goes out after approx. 4 seconds	Wiring, SRS MIL (A1e15), Intermittent short circuit to circuit 31 (X11/4 - A1e15), SRS voltage supply connector (X28/2) not connected, Time limit for DTC readout/erase exceeded.

Electrical Test Program - Test (driver-side or driver/passenger-side airbag)

⇒		Test scope	Test connection	Test condition	Nominal value	Possible cause/Remedy
9.0	☞	Wiring	<p>X11/13</p> 	<p>Ignition: OFF Disconnect and cover battery negative terminal. Disconnect SRS test connection (X11/13). Disconnect control module (N2/2).</p>	<p>< 1 Ω</p> <p>> 20 kΩ</p>	<p>Wiring.</p> <p>Short circuit, ⇒ 9.1</p>
9.1	☞	Isolation resistance	<p>X11/13</p> 	<p>Turn ignition key to position "1" and "2"</p>	<p>> 20 kΩ</p> <p>> 20 kΩ</p>	<p>Short to circuit 31</p> <p>Short to circuits 15/15R/30</p>

Electrical Test Program - Test (driver-side or driver/passenger-side airbag)

⇒		Test scope	Test connection	Test condition	Nominal value	Possible cause/Remedy
10.0	4	Wiring	<p>X11/13 N2/2</p> <p>8 —()— 13</p> <p>7 —()— 14</p> <p>X11/13</p> <p>6 —()— 7</p> <p>6 —()— 8</p> <p>6 —()— 8</p>	<p>Ignition: OFF</p> <p>Disconnect and cover battery negative terminal.</p> <p>Disconnect SRS test connection (X11/13).</p> <p>Disconnect control module (N2/2).</p>	<p>< 1 Ω</p> <p>> 20 kΩ</p>	<p>Wiring.</p> <p>Short circuit, ⇒ 10.1</p>
10.1	4	Isolation resistance	<p>X11/13</p> <p></p> <p>⊥ )— 8</p> <p>⊥ )— 7</p> <p>⊥ )— 6</p> <p>X11/13</p> <p> </p> <p>8 —()— +</p> <p>7 —()— +</p> <p>6 —()— +</p>		<p>> 20 kΩ</p> <p>> 20 kΩ</p>	<p>Short to circuit 31</p> <p>Short to circuits 15/15R/30</p>

Electrical Test Program – Test (driver-side or driver/passenger-side airbag)

Electrical Components in Passenger Compartment

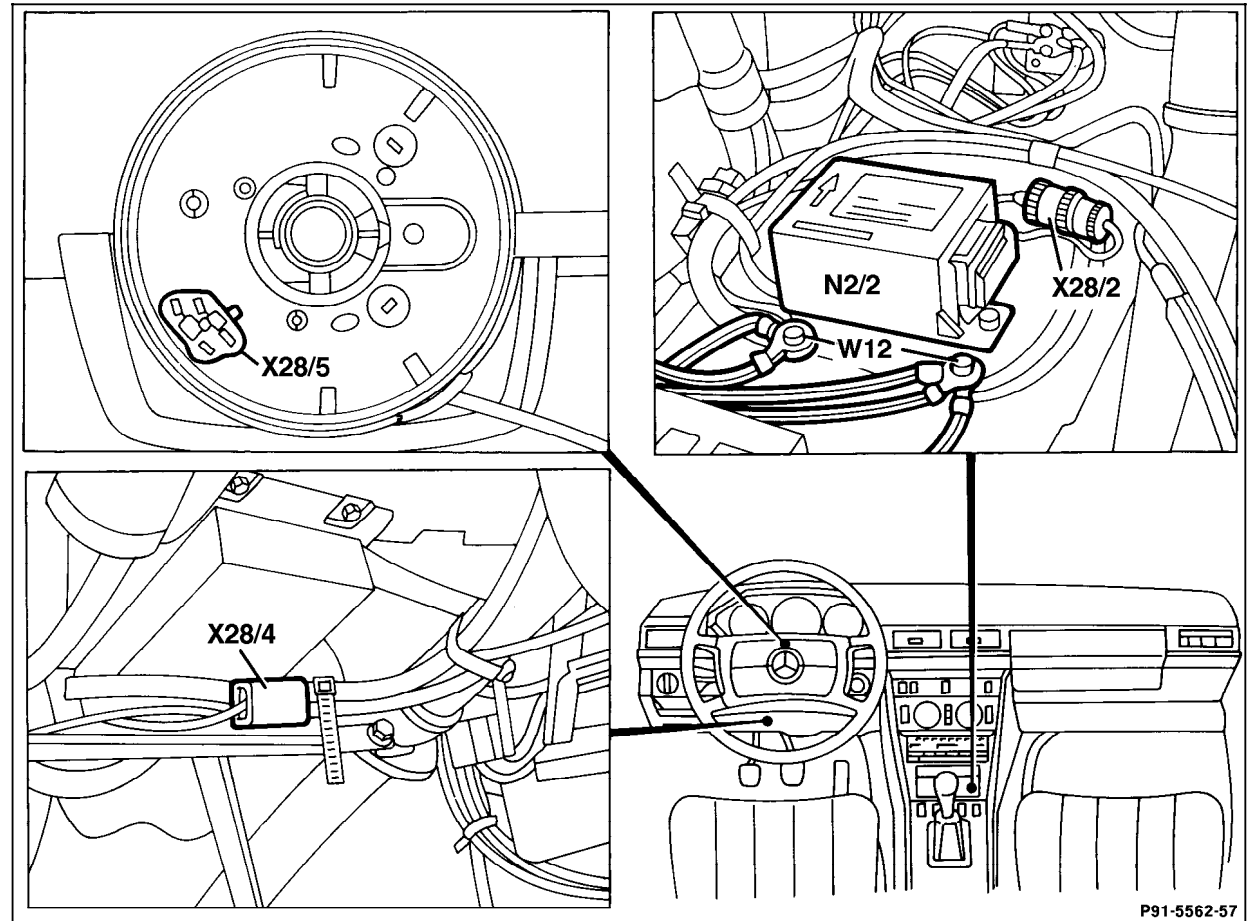


Figure 1

- X28/2 SRS voltage supply connector
- X28/4 Driver airbag squib connector
- X28/5 Airbag squib slip ring

P91-5562-57

P91-5562-57

Electrical Test Program – Test (driver-side or driver/passenger-side airbag)

Electrical Components in Passenger Compartment

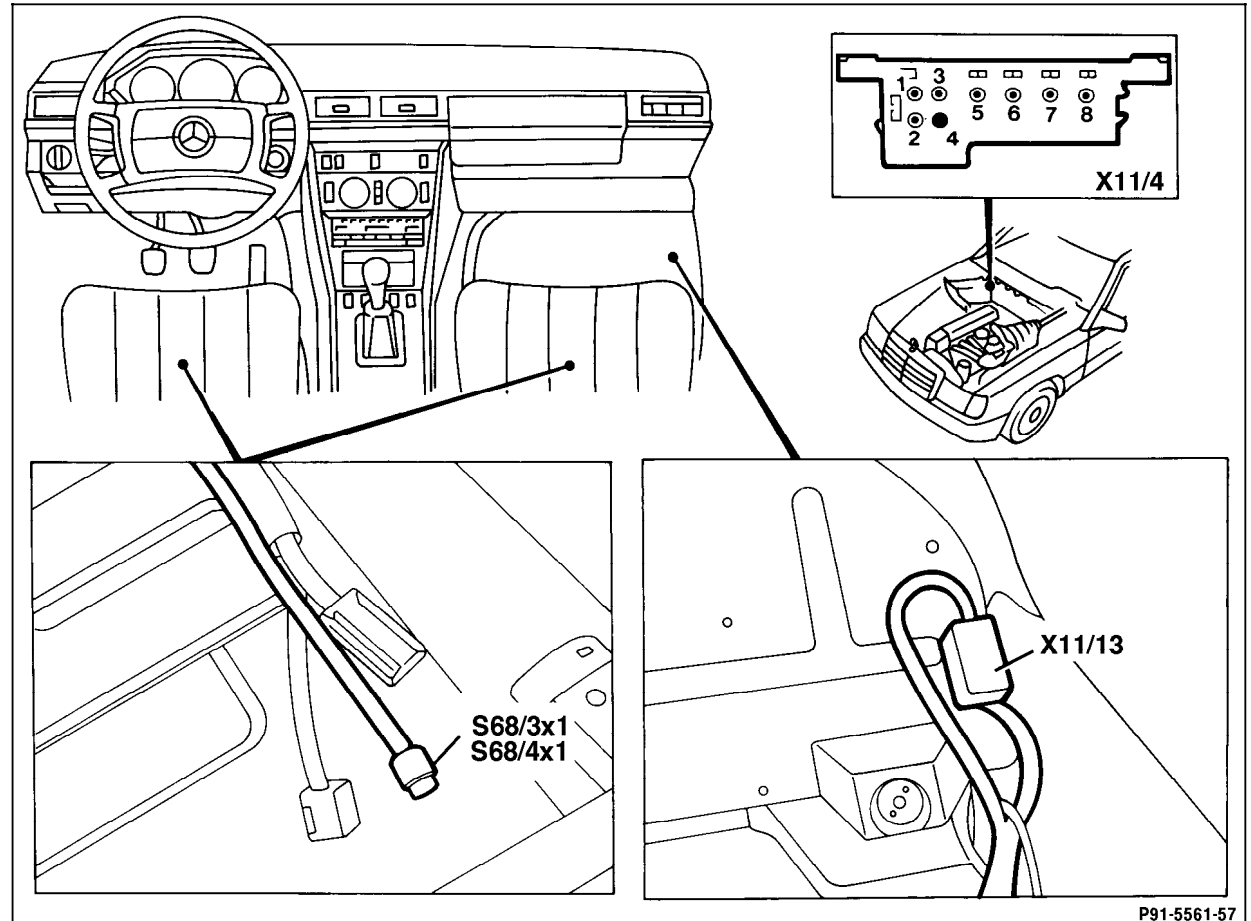


Figure 2

- S68/3x1 Left front seat belt buckle switch connector
- S68/4x1 Right front seat belt buckle switch connector
- X11/4 Data link connector
- X11/13 ETR test connection

Electrical Test Program – Test (driver-side or driver/passenger-side airbag)

Electrical Components in Passenger Compartment

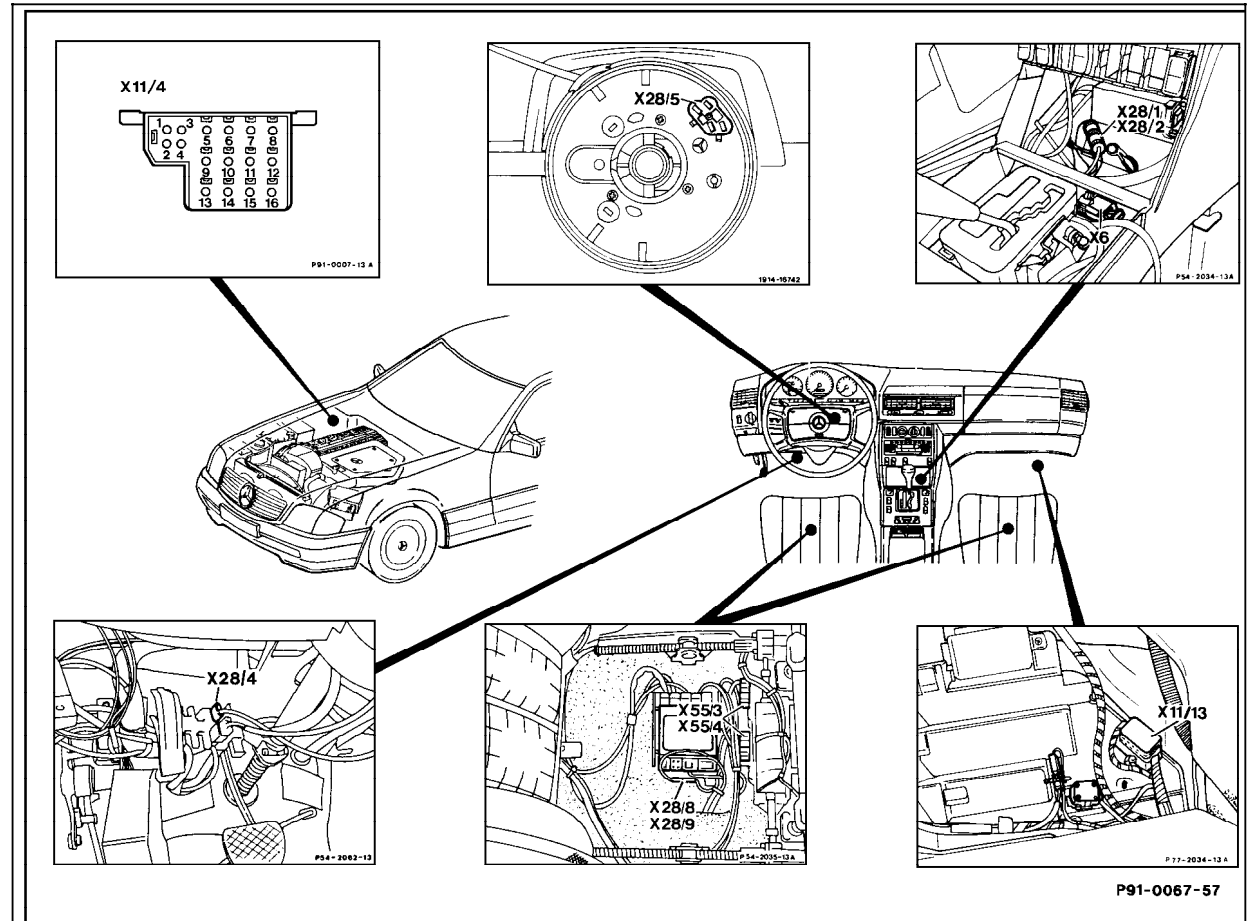


Figure 3

- X11/4 Data link connector (DTC readout)
- X11/13 ETR test connection
- X28/1 ETR voltage supply connector
- X28/2 SRS voltage supply connector
- X28/4 Driver airbag squib connector
- X28/5 Airbag squib slip ring
- X28/8 ETR connector (left seat plug connection)
- X28/9 ETR connector (right seat plug connection)
- X55/3 Left seat contact strip
- X55/4 Right seat contact strip

P91-0067-57

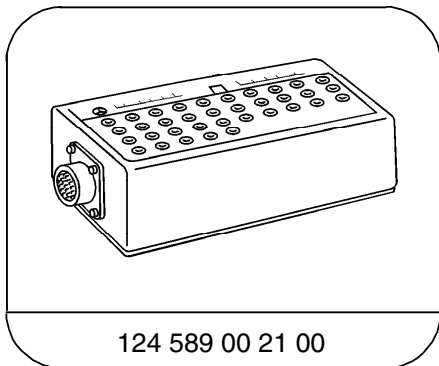
Electrical Test Program - Preparation for Test (ETR's)

Preliminary work:
 Diagnosis - Function Test 11

⚠ WARNING!

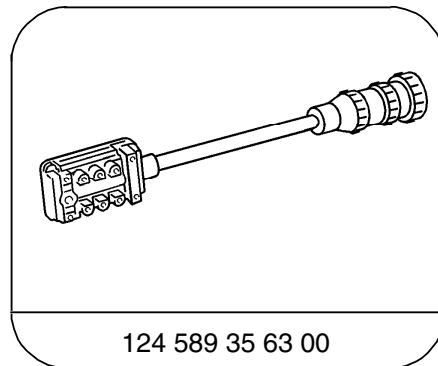
Before disconnecting the SRS test connection (X11/13), disconnect and cover the battery negative terminal.

Special Tools



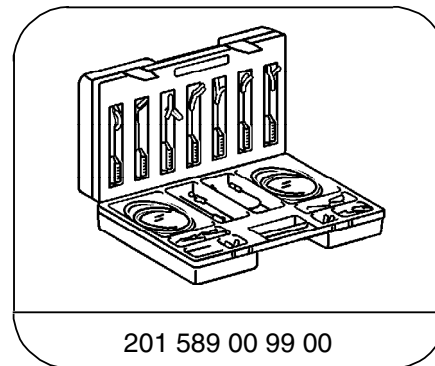
124 589 00 21 00

35-pin socket box



124 589 35 63 00

Test cable



201 589 00 99 00

Electrical connecting set

Equipment

Digital multimeter ¹⁾	Fluke 23, 83, 88 Sun DMM-5
----------------------------------	-------------------------------

¹⁾ Available through the MBUSA Standard Equipment Program.

Electrical Test Program - Preparation for Test (ETR's)

Connection Diagram - Digital Multimeter and Socket Box Tester

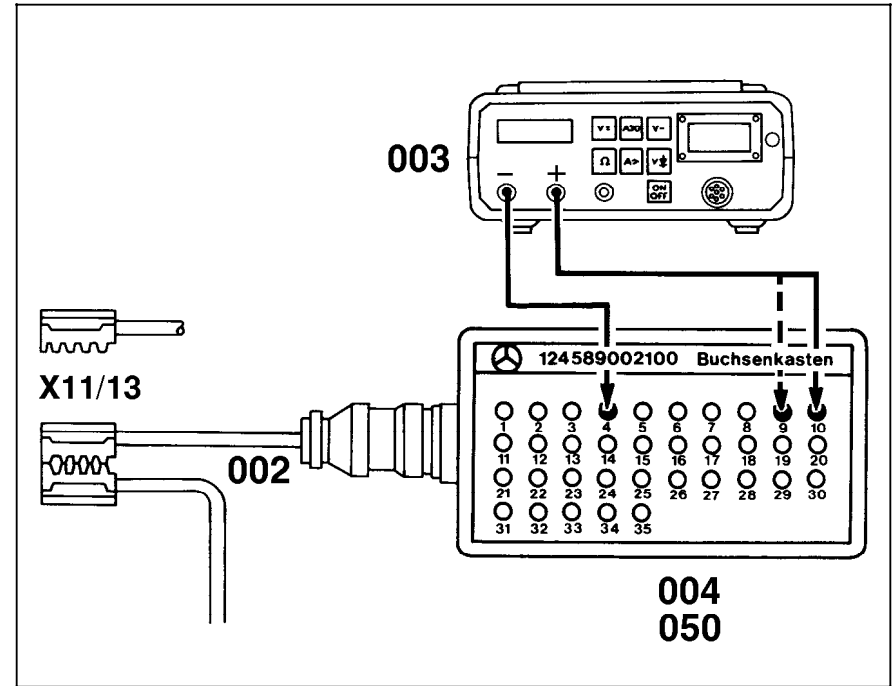



Figure 1
 002 Test cable 124 589 35 63 00
 003 Digital multimeter
 004 Socket box
 050 Socket box
 X11/13 SRS test connection (10-pole)

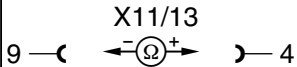
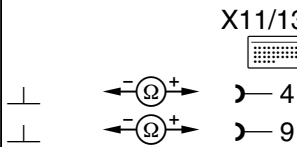
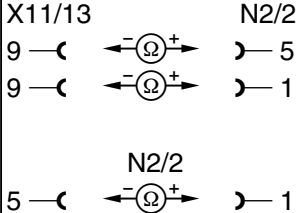
P91-5563-35

Electrical Test Program - Test (ETR's)

 This test has no DTC's.

This Test is necessary:







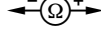
- after an accident
- if the seat belt/ETR is replaced
- if no fault is found even though DTC 3 and/or 4 is displayed
- Model 129: if the seat(s) are removed/reinstalled.

Test step DTC	Test scope	Test connection	Test condition	Nominal value	Possible cause/Remedy
⇒ 1.0	Left front ETR squib (R12/1)		Ignition: OFF Disconnect and cover battery negative terminal. Disconnect SRS test connection (X11/13)	2–5 Ω	< 2 Ω short circuit > 5 Ω ETR deployed or open circuit Model 129 Left contact strip (X55/3) disconnected
⇒ 1.1	Isolation Resistance			> 20 kΩ	Short to circuit 31 If the nominal values are obtained, but DTC 3 and/or 4 can not be erased ⇒ 1.2
⇒ 1.2	Wiring			> 20 kΩ	Short to circuit 31 If the nominal values are obtained, but DTC 3 and/or 4 can not be erased ⇒ 2.2

Electrical Test Program - Test (ETR's)

Test step DTC	Test scope	Test connection	Test condition	Nominal value	Possible cause/Remedy
⇒ 2.0	Right front ETR squib (R12/2)		Ignition: OFF Disconnect and cover battery negative terminal. Disconnect SRS test connection (X11/13)	2–5 Ω	< 2 Ω short circuit > 5 Ω ETR deployed or open circuit Model 129 Right contact strip (X55/4) disconnected
⇒ 2.1	Isolation Resistance			> 20 kΩ	Short to circuit 31 If the nominal values are obtained, but DTC 3 and/or 4 can not be erased ⇒ 2.2
⇒ 2.2	Wiring		Disconnect control module (N2/2) connector	< 1 Ω > 20 kΩ	Wiring Short circuit

Electrical Test Program – Test (test if there is no DTC)

⇒		Test scope	Test connection	Test condition	Nominal value	Possible cause/Remedy
2.0		Wiring	X11/4 6 ¹⁾ —  ←  → 3 30 ²⁾ —  ←  → 3	Ignition: OFF Disconnect and cover battery negative terminal. Disconnect SRS test connection (X11/13). Disconnect connector from control module (N2/2).	< 1 Ω	Wiring, ⇒ 2.1
2.1		Wiring	 —  → X11/4 1		< 1 Ω	Wiring.

1) Vehicles with 8- or 16-pole data link connector (X11/4).

2) Vehicles with 38-pole data link connector (X11/4).