

Electrical Test Program - Component Locations

Figure 1

- M27 Left front ESA motor group (with memory)
- M27m1 Fore/aft motor
- M27m2 Rear raise/lower motor
- M27m3 Front raise/lower motor
- M27m4 Head restraint raise/lower motor
- M27m5 Backrest fore/aft motor

Note:

Right power seat layout (not pictured) similar to left

- M28 Right front ESA motor group (with memory)
- M28m1 Fore/aft motor
- M28m2 Rear raise/lower motor
- M28m3 Front raise/lower motor
- M28m4 Head restraint raise/lower motor
- M28m5 Backrest fore/aft motor

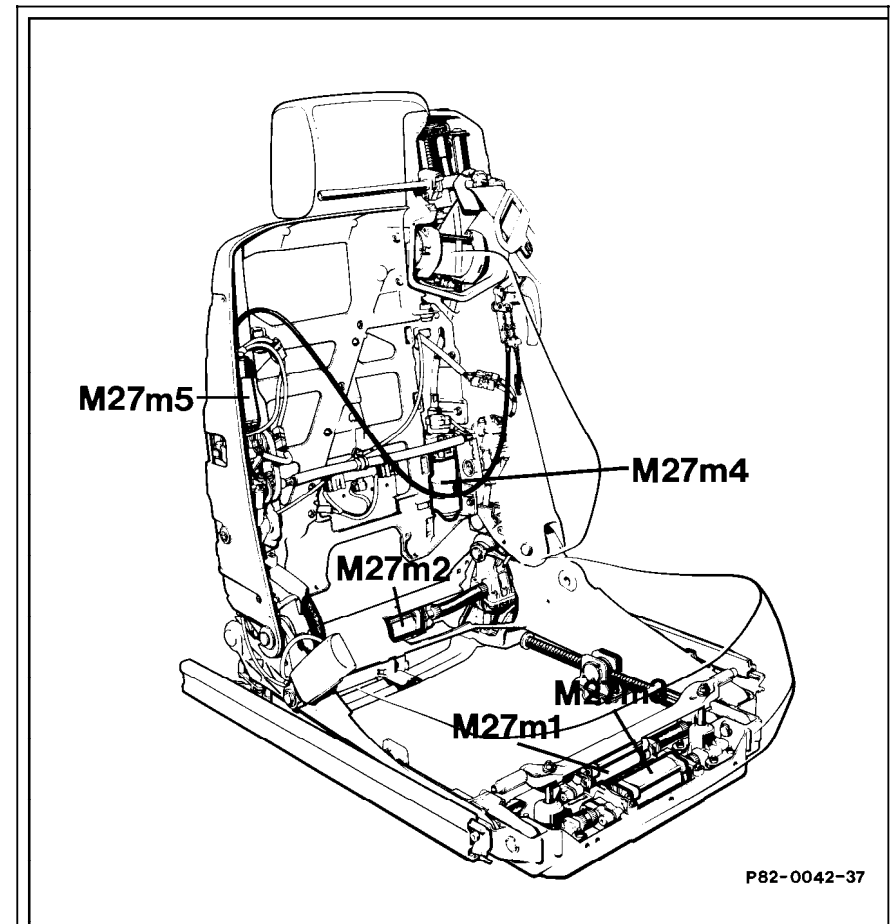

P82-0042-37

P82-0042-37

Electrical Test Program - Component Locations

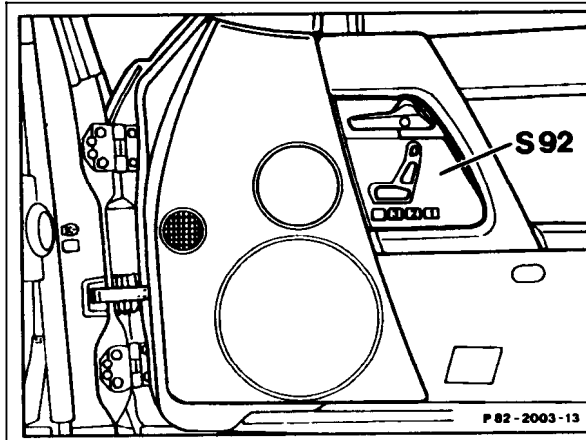

P82-2003-13

Figure 2

- S92 Right front ESA switch group (with memory)
- S91 Left front ESA switch group (with memory)
(not pictured, layout similar to right)

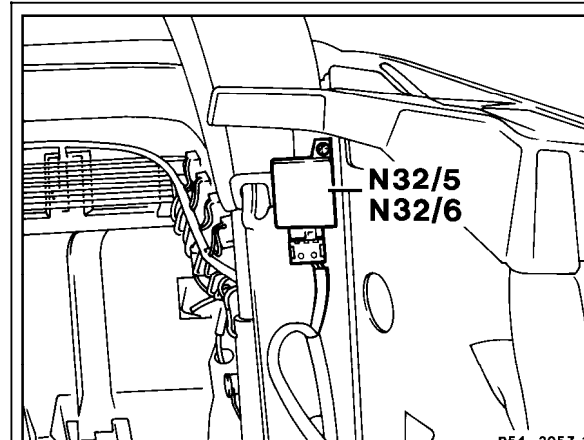

P54-2057-13

Figure 3

- N32/5 Left seat proximity control module (soft top compartment panel removed)
- N32/6 Right seat proximity control module
(not pictured, layout similar to left)

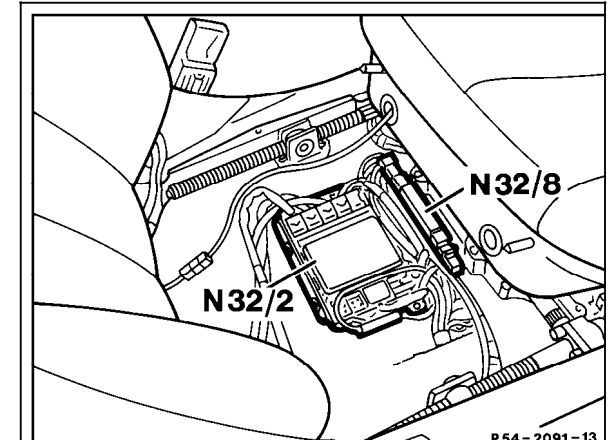

P54-2091-13

Figure 4

- N32/2 Right front ESA control module (with memory)
- N32/8 Right backrest lock safety package
- N32/7 Left backrest lock safety package
(not pictured, layout similar to right)
- N32/1 Left front ESA control module (with memory)
(not pictured, layout similar to right)

Electrical Test Program - Component Locations

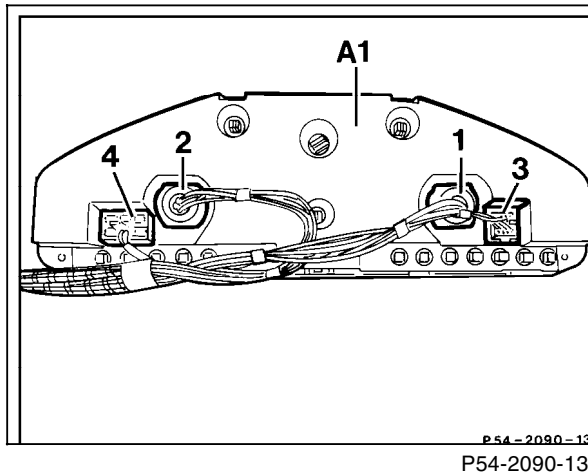

Figure 5

- A1 Instrument cluster, reverse side
- 2 Connector, with terminal no. 7 for backrest lock warning lamp