

Electrical Test Program - Testing

Test step DTC	Test scope	Test connection	Test condition	Nominal value	Possible cause/Remedy
⇒ 1.0	Non – USA vehicle only Continue to next step				
⇒ 2.0	Left front power seat motor group, fore/aft motor (M25m1) Voltage supply		Ignition: ON Disconnect contact strip (X55/3). Press left front power seat switch (S22s3): forward backward	11 – 14 V -11 to -14 V	Wiring, Left front power seat switch (S22).
⇒ 3.0	Left front power seat motor group, fore/aft motor (M25m1) Resistance		–	0.5 – 15 Ω	Left front power seat motor group, fore/aft motor (M25m1).
⇒ 4.0	Left front power seat motor group, front raise/lower motor (M25m3) Voltage supply		Ignition: ON Disconnect contact strip (X55/3). Press seat switch (S22s2): seat front height up seat front height down	11 – 14 V -11 to -14 V	Wiring, Left front power seat switch (S22).
⇒ 5.0	Left front power seat motor group, front raise/lower motor (M25m3) Resistance		–	0.5 – 15 Ω	Left front power seat motor group, front raise/lower motor (M25m3).

Electrical Test Program - Testing

Test step DTC	Test scope	Test connection	Test condition	Nominal value	Possible cause/Remedy
⇒ 6.0	Left front power seat motor group, rear raise/lower motor (M25m2) Voltage supply		Ignition: ON Disconnect contact strip (X55/3). Press seat switch (S22s2): seat rear height up seat rear height down	11 – 14 V -11 to -14 V	Wiring, Left front power seat switch (S22).
⇒ 7.0	Left front power seat motor group, rear raise/lower motor (M25m2) Resistance		–	0.5 – 15 Ω	Left front power seat motor group, rear raise/lower motor (M25m2).

Electrical Test Program - Testing

Test step DTC	Test scope	Test connection	Test condition	Nominal value	Possible cause/Remedy
⇒ 8.0	Left front power seat motor group, backrest fore/aft motor (M25m5) Voltage supply		Ignition: ON Disconnect contact strip (X55/3). Press seat switch (S22s5): backrest forward backrest rearward	11 – 14 V -11 to -14 V	Wiring, Left front power seat switch (S22).
⇒ 9.0	Left front power seat motor group, backrest fore/aft motor (M25m5) Resistance		–	0.5 – 15 Ω	Left front power seat motor group, backrest fore/aft motor (M25m5).
⇒ 10.0	Left front power seat motor group, head restraint raise/lower motor (M25m4) Voltage supply		Ignition: ON Disconnect contact strip (X55/3). Press seat switch (S22s1): head restraint up head restraint down	11 – 14 V -11 to -14 V	Wiring, Left front power seat switch (S22).
⇒ 11.0	Left front power seat motor group, head restraint raise/lower motor (M25m4) Resistance		–	0.5 – 15 Ω	Left front power seat motor group, head restraint raise/lower motor (M25m4).

Electrical Test Program - Testing

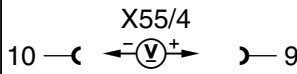
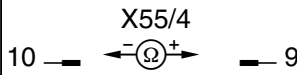
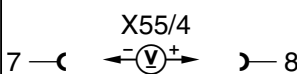
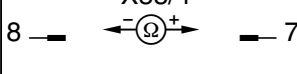
Test step DTC	Test scope	Test connection	Test condition	Nominal value	Possible cause/Remedy
⇒ 12.0 thru 16.0	Non – USA vehicle only Continue to next step				
⇒ 17.0	Right front power seat motor group, fore/aft motor (M26m1) Voltage supply	X55/4 10 —  — 9	Ignition: ON Disconnect contact strip (X55/4). Press left front power seat switch (S23s3): forward backward	11 – 14 V -11 to -14 V	Wiring, Right front power seat switch (S23).
⇒ 18.0	Right front power seat motor group, fore/aft motor (M26m1) Resistance	X55/4 10 —  — 9	–	0.5 – 15 Ω	Right front power seat motor group, fore/aft motor (M26m1).
⇒ 19.0	Right front power seat motor group, front raise/lower motor (M26m3) Voltage supply	X55/4 7 —  — 8	Ignition: ON Disconnect contact strip (X55/4). Press seat switch (S23s2): seat front height up seat front height down	11 – 14 V -11 to -14 V	Wiring, Right front power seat switch (S23).
⇒ 20.0	Right front power seat motor group, front raise/lower motor (M26m3) Resistance	X55/4 8 —  — 7	–	0.5 – 15 Ω	Right front power seat motor group, front raise/lower motor (M26m3).

Electrical Test Program - Testing

Test step DTC	Test scope	Test connection	Test condition	Nominal value	Possible cause/Remedy
⇒ 21.0	Right front power seat motor group, rear raise/lower motor (M26m2) Voltage supply	X55/4 11 —(— ⊖ ⊕ —)— 12	Ignition: ON Disconnect contact strip (X55/4). Press seat switch (S23s2): seat rear height up seat rear height down	11 – 14 V -11 to -14 V	Wiring, Right front power seat switch (S23).
⇒ 22.0	Right front power seat motor group, rear raise/lower motor (M26m2) Resistance	X55/4 12 — — ⊖ ⊕ — — 11	–	0.5 – 15 Ω	Right front power seat motor group, rear raise/lower motor (M26m2).

Electrical Test Program - Testing

Test step DTC	Test scope	Test connection	Test condition	Nominal value	Possible cause/Remedy
⇒ 23.0	Right front power seat motor group, backrest fore/aft motor (M26m5) Voltage supply	X55/4 2 —(←(V)→)— 1	Ignition: ON Disconnect contact strip (X55/4). Press seat switch (S23s5): backrest forward backrest rearward	11 – 14 V -11 to -14 V	Wiring, Right front power seat switch (S23).
⇒ 24.0	Right front power seat motor group, backrest fore/aft motor (M26m5) Resistance	X55/4 2 —(←(Ω)→)— 1	–	0.5 – 15 Ω	Right front power seat motor group, backrest fore/aft motor (M26m5).
⇒ 25.0	Right front power seat motor group, head restraint raise/lower motor (M26m4) Voltage supply	X55/4 3 —(←(V)→)— 4	Ignition: ON Disconnect contact strip (X55/4). Press seat switch (S23s1): head restraint up head restraint down	11 – 14 V -11 to -14 V	Wiring, Right front power seat switch (S23).
⇒ 26.0	Right front power seat motor group, head restraint raise/lower motor (M26m4) Resistance	X55/4 3 —(←(Ω)→)— 4	–	0.5 – 15 Ω	Right front power seat motor group, head restraint raise/lower motor (M26m4).

Electrical Test Program - Testing

Test step DTC	Test scope	Test connection	Test condition	Nominal value	Possible cause/Remedy
⇒ 27.0 thru 30.0	Non – USA vehicles only Continue to next step				
⇒ 31.0	Left front power seat switch (S22) Voltage supply	<p>2 —(←(V)→)— 1 (4) (4)</p>	Ignition: ON Disconnect connector (4) from seat switch (S22)	11 – 14 V	Wiring, Convenience relay module (K24).
		<p>2 —(←(V)→)— 2 (2) (1)</p>	Disconnect connectors (1, 2) from seat switch (S22)	11 – 14 V	
⇒ 32.0	Right front power seat switch (S23) Voltage supply	<p>2 —(←(V)→)— 2 (6) (5)</p>	Ignition: ON Disconnect connectors (5, 6) from seat switch (S23)	11 – 14 V	Wiring, Convenience relay module (K24).
		<p>2 —(←(V)→)— 1 (8) (8)</p>	Disconnect connector (8) from seat switch (S23)	11 – 14 V	

Electrical Test Program - Testing

Test step DTC	Test scope	Test connection	Test condition	Nominal value	Possible cause/Remedy
⇒ 33.0 Up to 2/97	Convenience relay module (K24) Voltage supply	<p>K24 5 —(V)— 3</p>	Ignition: OFF Disconnect module (K24)	11 – 14 V	Wiring
		<p>5 —(V)— 2</p>		11 – 14 V	
		<p>5 —(V)— 4</p>	Ignition key in position "1"	11 – 14 V	
			Ignition: OFF Disconnect module (K24)		
As of 3/97		<p>K24 6 —(V)— 8</p>		11 – 14 V	
		<p>6 —(V)— 3</p>		11 – 14 V	
		<p>6 —(V)— 2</p>	Ignition key in position "1"	11 – 14 V	
		<p>6 —(V)— 4</p>	Ignition key in position "1"	11 – 14 V	

Electrical Test Program - Testing

Test step DTC	Test scope	Test connection	Test condition	Nominal value	Possible cause/Remedy
⇒ 34.0 Up to 2/97	Door switch (S17/3, S17/4) Voltage supply	<p>K24 6 —(←(V)→)— 2</p>	Ignition: OFF Disconnect module (K24) Front doors: closed Left front door: open Left front door: closed Right front door: open	0–2 V 11 – 14 V 0–2 V 11 – 14 V	Wiring, Left door switch (S17/3), Right door switch (S17/4), Pneumatic control module (A37/2), Convenience control module (N57).
As of 3/97		<p>K24 3 —(←(V)→)— 1</p> <p>K24 3 —(←(V)→)— 7</p>	Ignition: OFF Disconnect module (K24) Left front door: open Left front door: closed Right front door: open Right front door: closed	11 – 14 V 0–2 V 11 – 14 V 0–2 V	Wiring, Left door switch (S17/3), Right door switch (S17/4),

Electrical Test Program - Testing

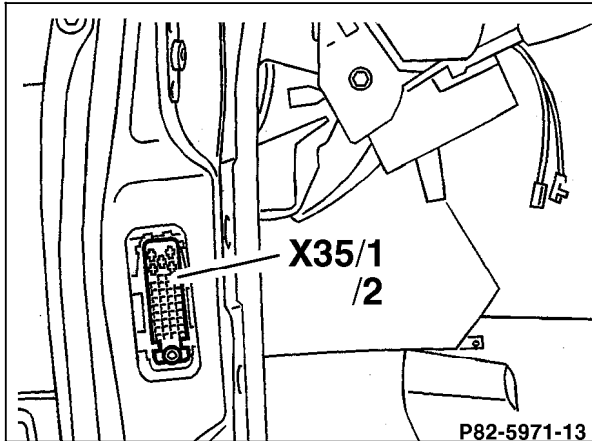

Figure 1

- X35/1 Left front door plug connection
- X35/2 Right front door plug connection

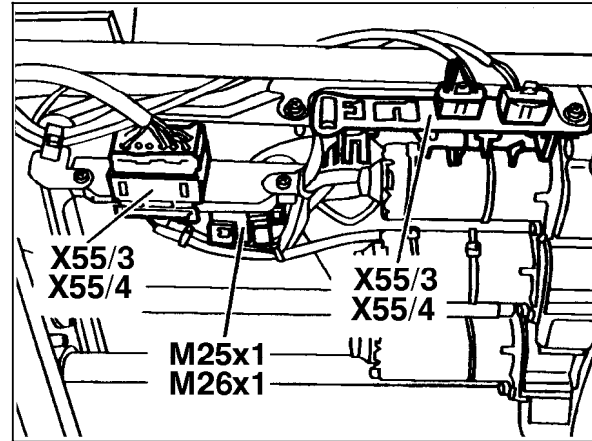

Figure 2

- X55/3 Left seat contact strip
- X55/4 Right seat contact strip
- M25x1 Left front power seat motor group connector
- M26x1 Right front power seat motor group connector

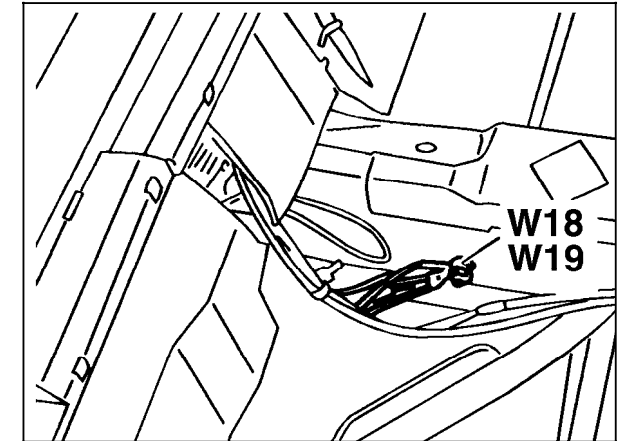

Figure 3

- W18 Ground (left front seat crossmember)
- W19 Ground (right front seat crossmember)