

Electrical Test Program - Preparation for Test

1. Battery voltage 11 – 14 V.
2. Fuses F3-30, F3-37, F3-38, F3-40, F3-41 O.K.
3. Loosen seat cushion at front and fold upward.

Electrical wiring diagrams

Electrical Troubleshooting Manual, Model 140.

Special Tools

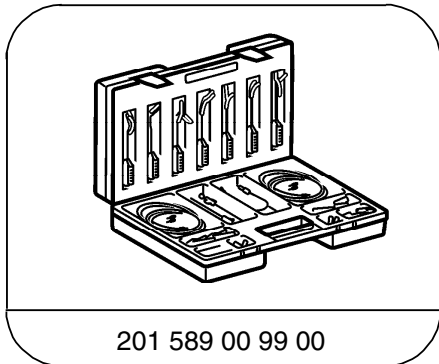

201 589 00 99 00

Electrical connecting set

Equipment

Digital multimeter ¹⁾

Fluke models 23, 83, 85, 87

¹⁾ Available through the MBUSA Standard Equipment Program.