

Electrical Test Program – Connection of Components

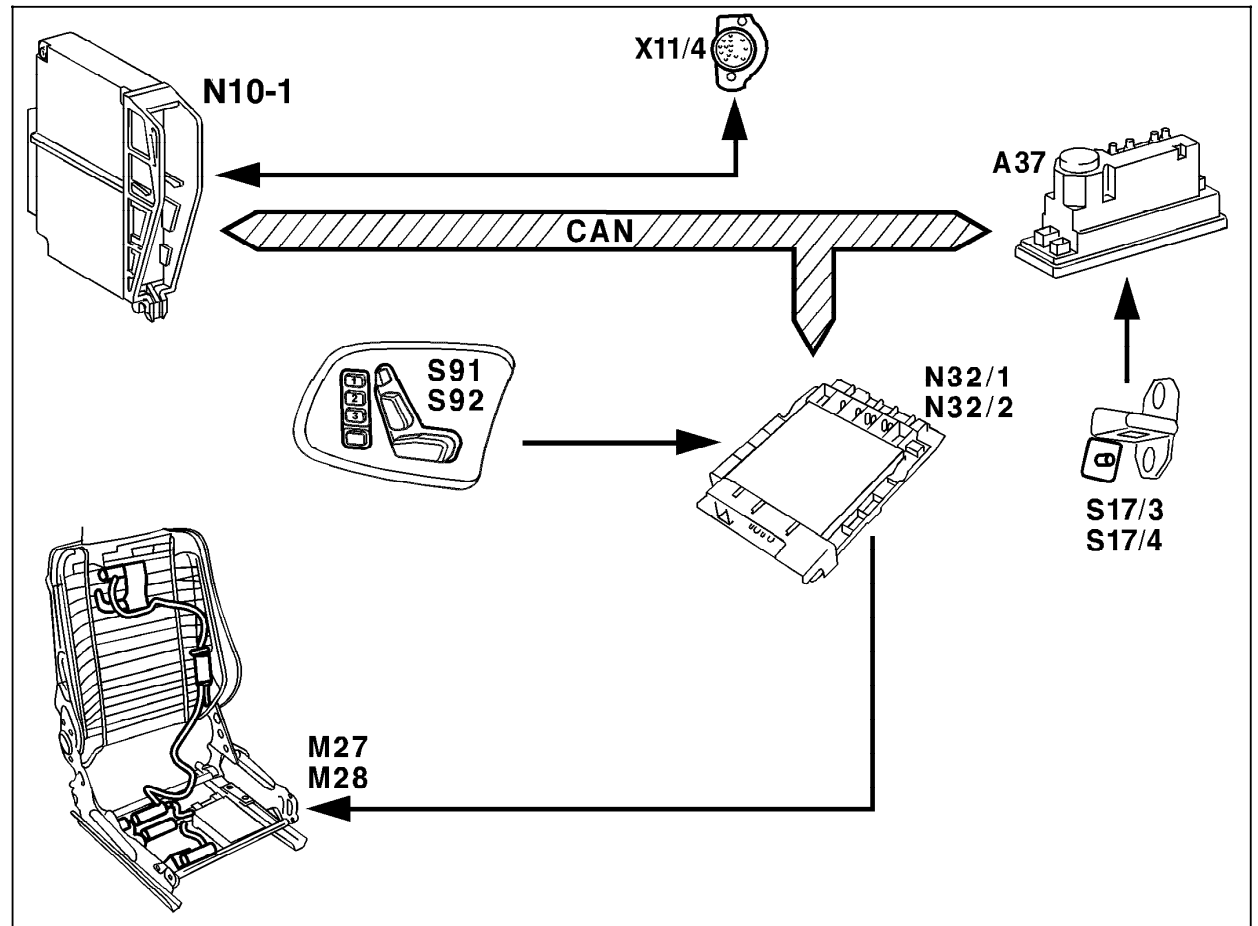

Figure 1

- A34 PSE control module, combined functions
- CAN Control-Area-Network
- M27 Left front ESA motor group (with memory)
- M28 Right front ESA motor group (with memory)
- N10-1 Combination control module
- N32/1 Left front ESA control module (with memory)
- N32/2 Right front ESA control module (with memory)
- S17/3 Left front door switch
- S17/4 Right front door switch
- S91 Left front ESA switch group (with memory)
- S92 Right front ESA switch group (with memory)
- X11/4 Data link connector (DTC readout)

U91.29-0208-06