

Electrical Test Program – Preparation for Test

Test Conditions

1. Battery voltage, 11 – 14 V.
2. Fuse 6, circuit 15 [in Fuse_relaz (F1)] in proper working condition.
3. Fuse in auxiliarz fuse holder (F24) in proper working condition.

Electrical wiring diagrams :

Electrical Troubleshooting Manual, Model 202.

Special Tools

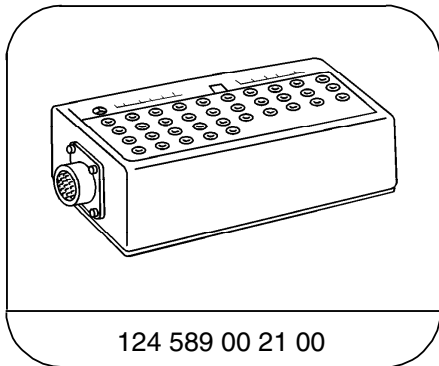

124 589 00 21 00

35-pin socket box

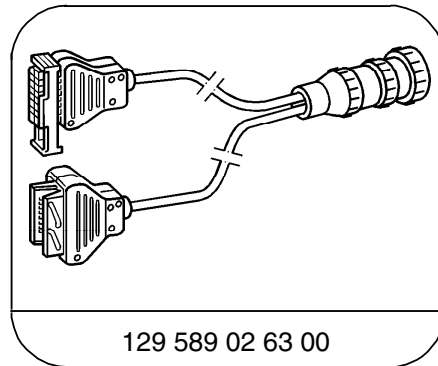

129 589 02 63 00

16-pin test cable

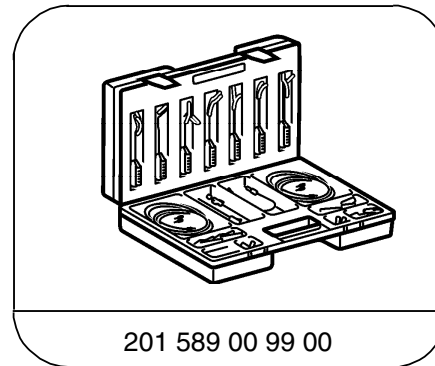

201 589 00 99 00

Electrical connecting set

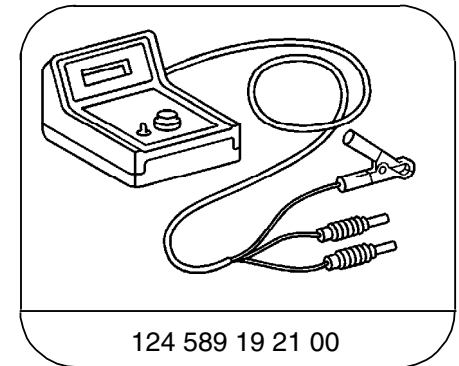

124 589 19 21 00

Pulse counter

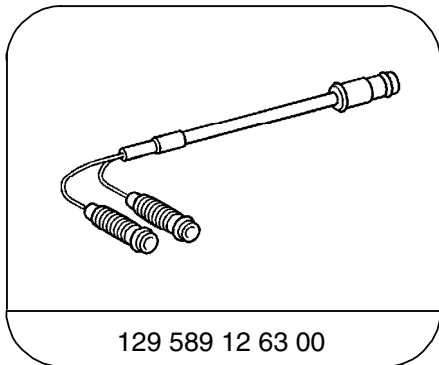

129 589 12 63 00

Test cable

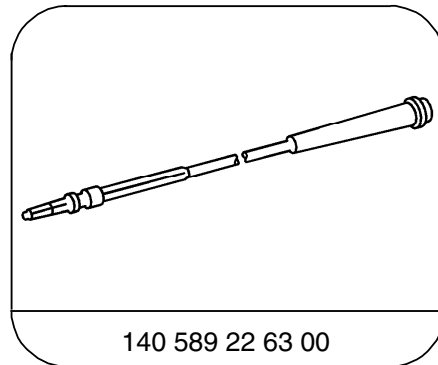

140 589 22 63 00

Adapter cable

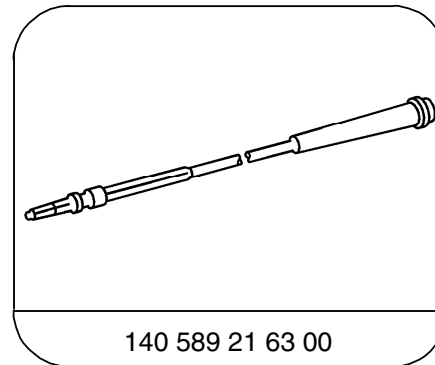

140 589 21 63 00

Adapter cable

Electrical Test Program – Preparation for Test

Conventional tools, test equipment

Description	Brand, model, etc.
Multimeter ¹⁾	Fluke models 23, 83, 85, 87

¹⁾ Available through the MBUSA Standard Equipment Program.

Electrical Test Program – Preparation for Test

Connection Diagram

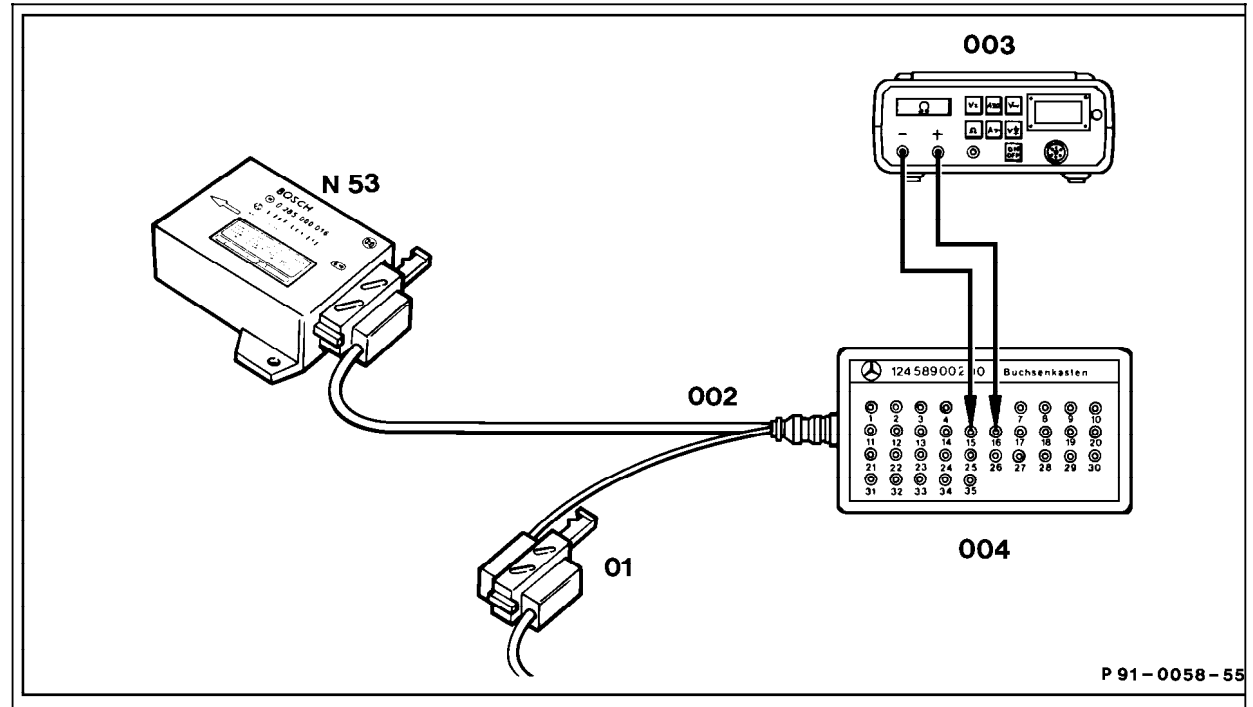

Figure 1

- N53 RB control module
- 01 Vehicle harness (RB control module)
- 002 Test cable
- 003 Digital multimeter
- 004 Socket box