

Electrical Test Program – Component Locations

Component Locations in Engine Compartment

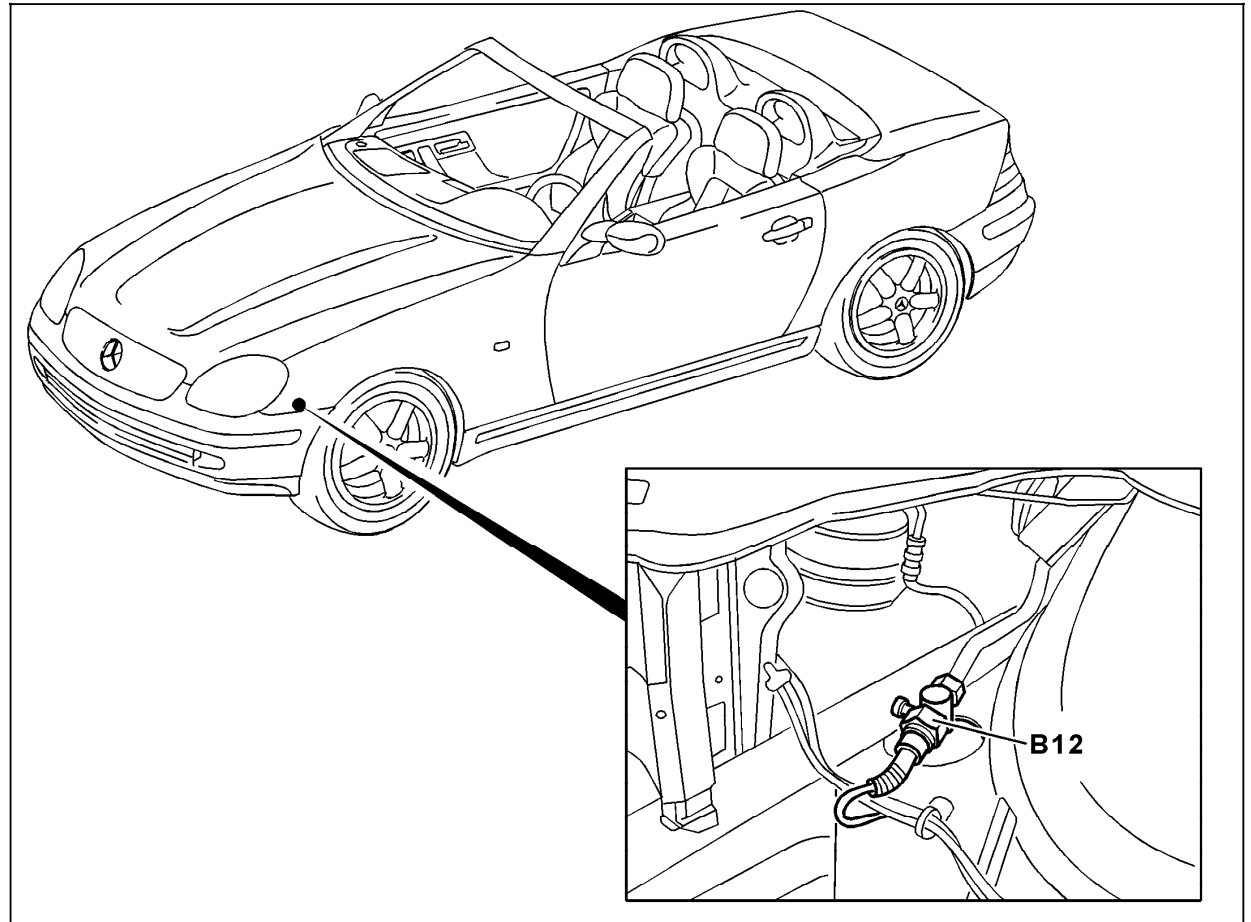

Figure 1

B12 Refrigerant pressure sensor

P83.30-0573-06

Electrical Test Program – Component Locations

Components Location in Engine Compartment

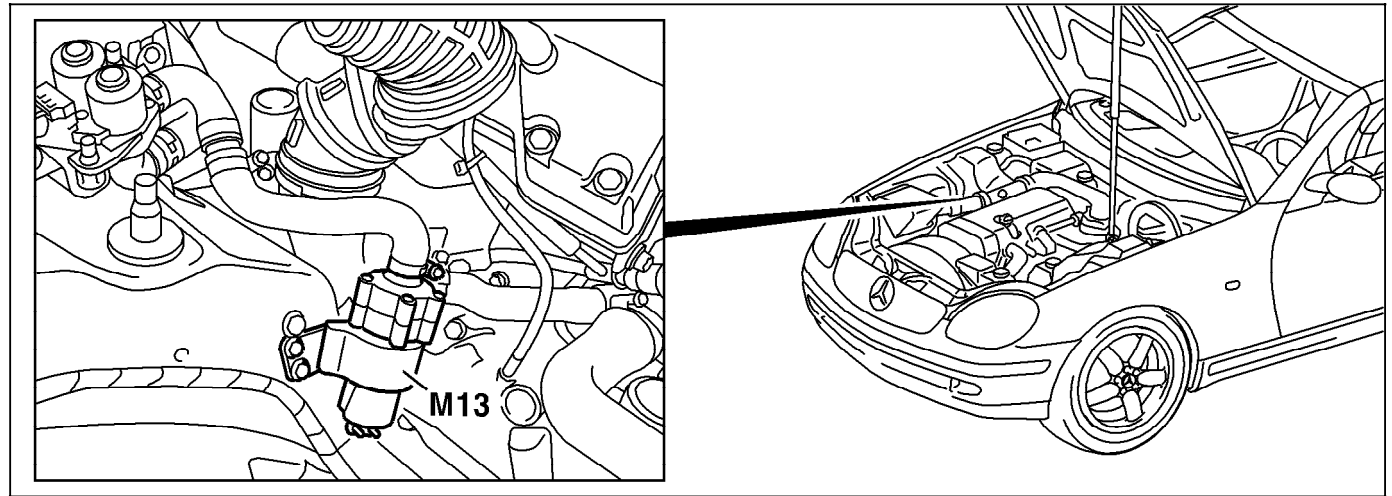

Figure 2

M13 Coolant circulation pump

P83.20-2035-04

Electrical Test Program – Component Locations

Components Location in Passenger Compartment

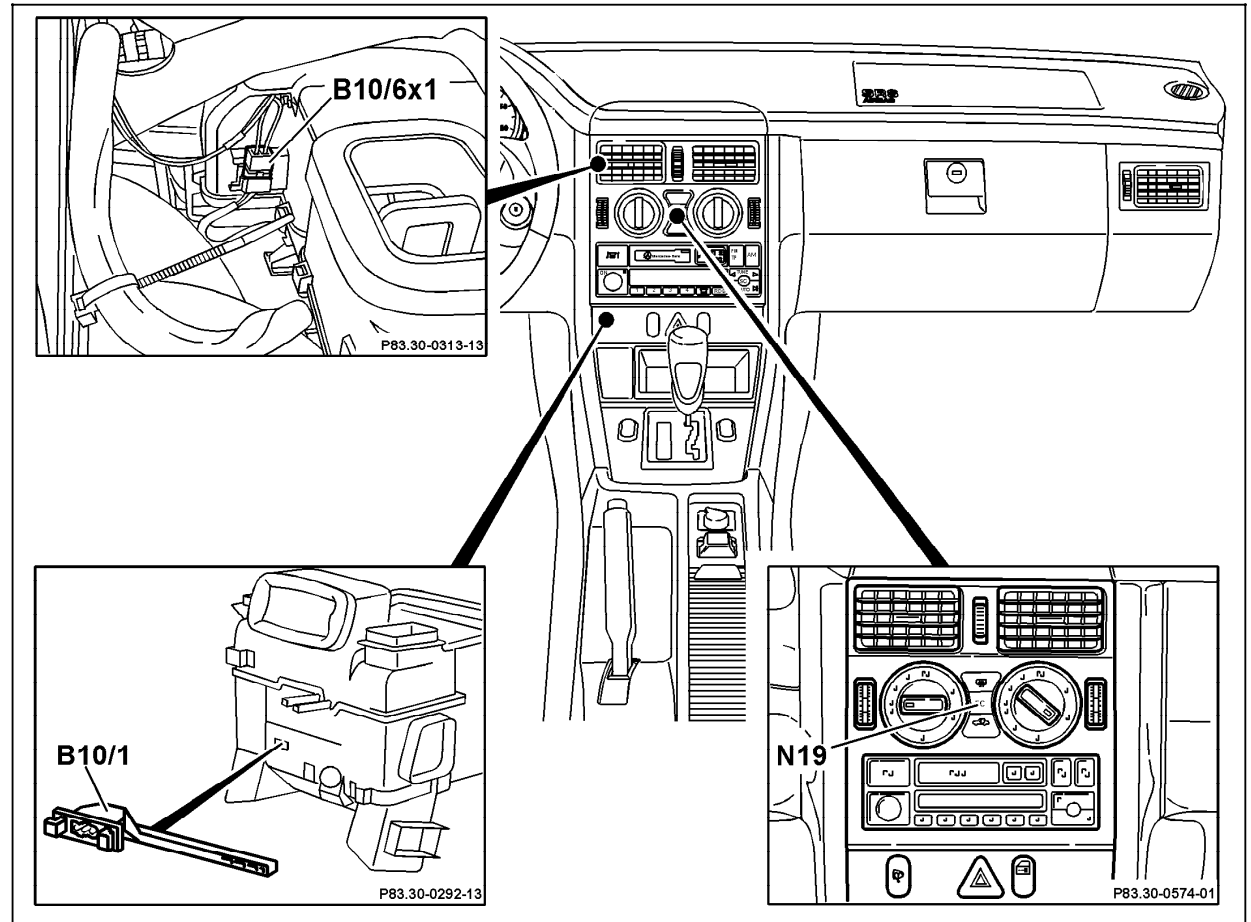

Figure 3

- B10/1 Heater core temperature sensor
- B10/6x1 Evaporator temperature sensor connector
- N19 A/C pushbutton control module