

Electrical Test Program – Preparation for Test

- Remove A/C pushbutton control module (N22).

Electrical wiring diagrams :
Electrical Troubleshooting Manual, Model 202.

Note:

Upon completion of test, erase DTC memory from A/C pushbutton control module (see 15).

Special Tools

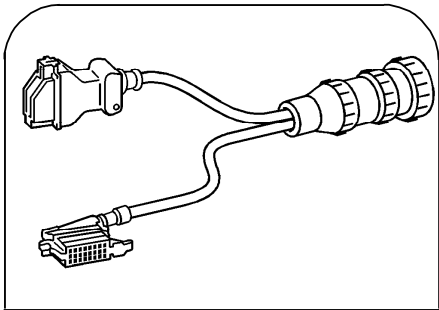

126 589 20 63 00

27-pin test cable

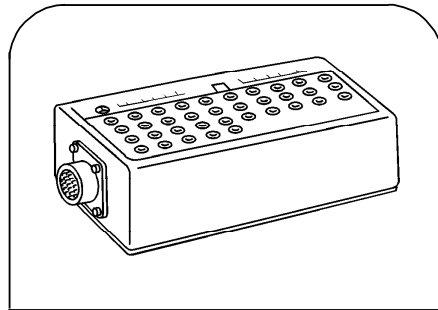

124 589 00 21 00

35-pin socket box

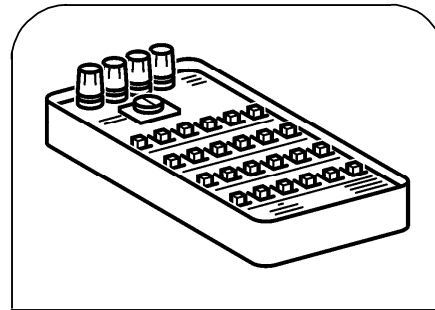

124 589 09 63 00

Ohm decade

Conventional tools, test equipment

Description	Brand, model, etc.
Multimeter ¹⁾	Fluke models 23, 83, 85, 87

¹⁾ Available through the MBUSA Standard Equipment Program.

Electrical Test Program - Preparation for Test

Connection Diagram – Socket Box

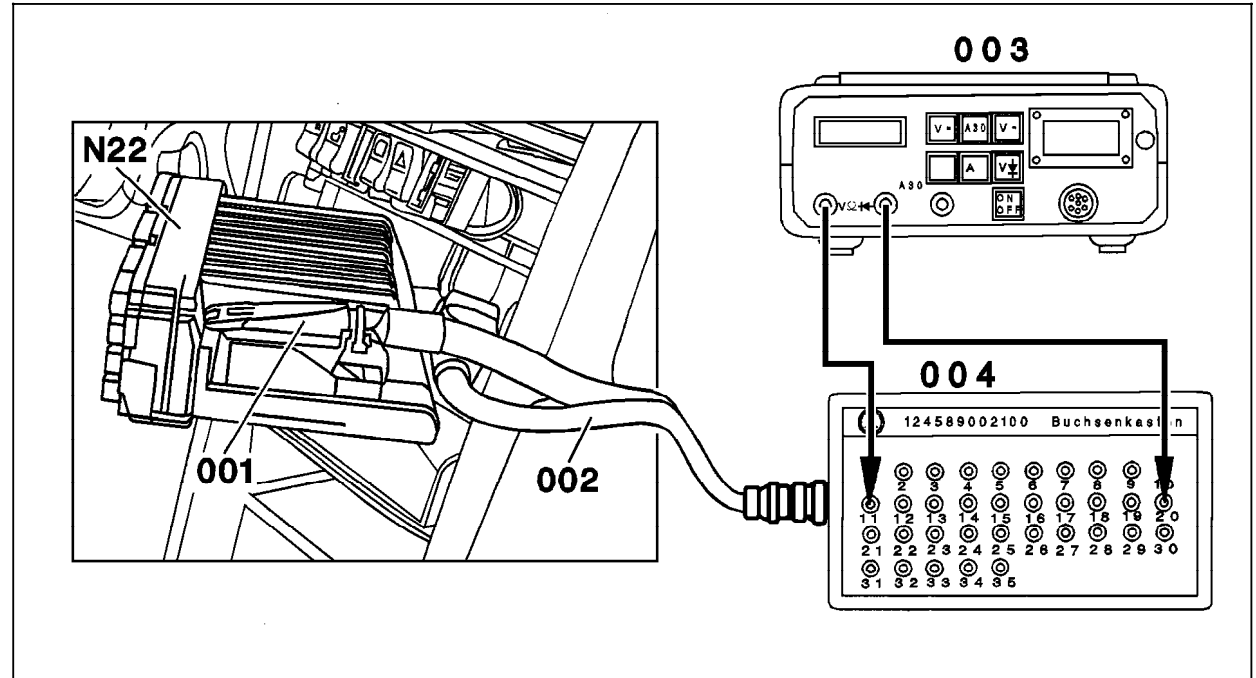

Figure 1

- 001 Right connector, A/C pushbutton control module
- 002 Test cable
- 003 Multimeter
- 004 Socket box
- N22 A/C pushbutton control module

P83-5679-55