

Pneumatic Test Program – Component Locations

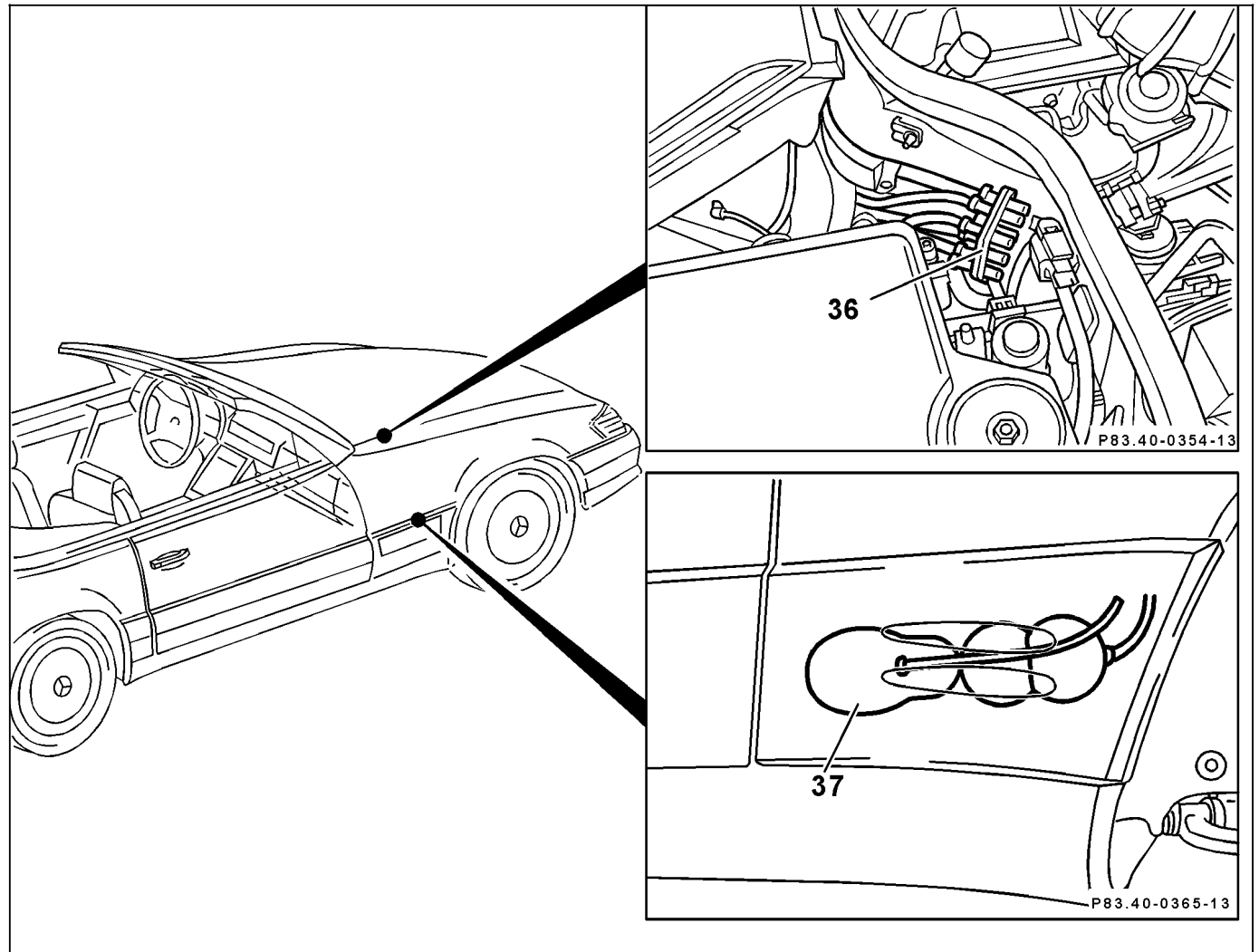

Figure 1

- 36 Vacuum distributor block
- 37 Vacuum reservoir

P83.40-0366-06

Pneumatic Test Program – Component Locations

Figure 2

- 36 Vacuum distributor block
- 38 Defroster flap vacuum actuator
- 39 Footwell flap vacuum actuator
- 41 Diverter flap vacuum actuator
- 42 Fresh/recirculating air flap vacuum actuator
- 43 Left main air flap vacuum actuator
- 44 Right main air flap vacuum actuator
- 45 Center air outlet blend air flap vacuum actuator
- 46 Left air outlet vacuum actuator (open-close)
- 47 Center air outlet vacuum actuator (open-close)
- 48 Right side air outlet vacuum actuator (open-close)
- Y11 Valve block (15 connector)

- hbl Light blue
- drt Dark red
- ge Yellow
- gr gray
- mgn Medium green
- rt Red
- ws White
- dgn Dark green
- gt gray
- sw schwarz

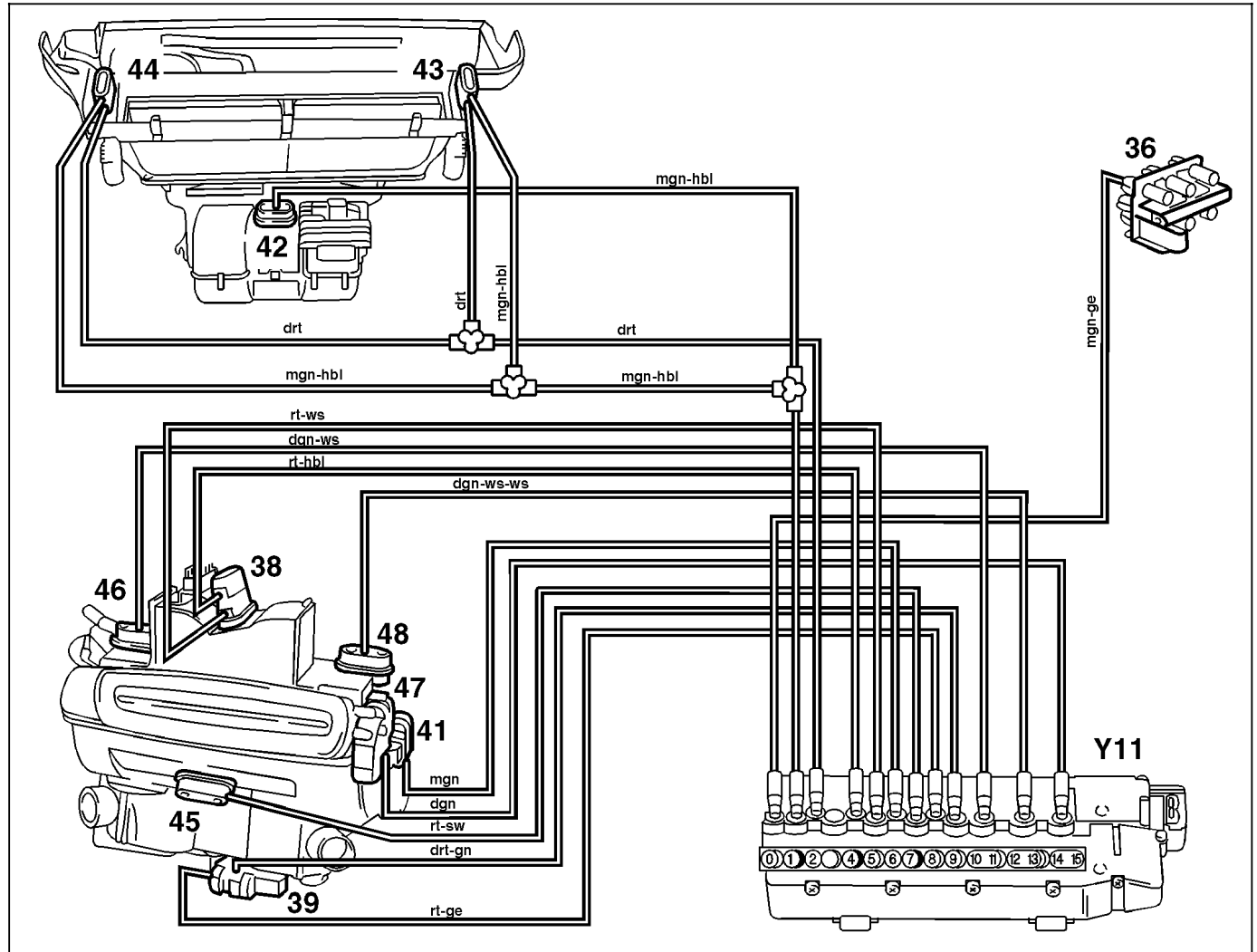

P83.40-0353-06