

Hydraulic Test Program - Component Locations

Hydraulic Components
Model 124.128

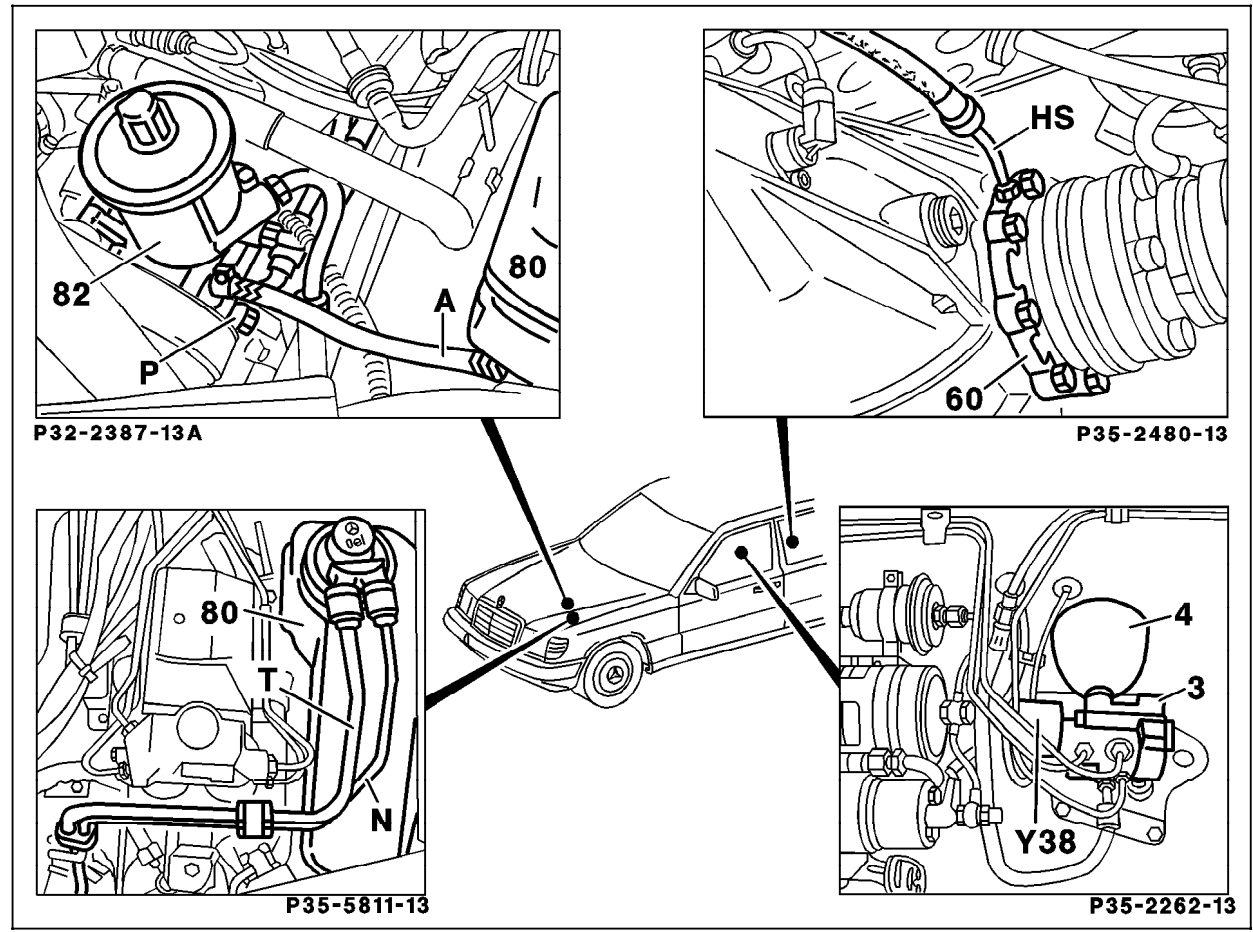

Figure 1

- 3/4 Hydraulic unit with pressure reservoir
- 60 Bearing cover plate with ring cylinder (M104)
- 80 Hydraulic oil reservoir
- 82 Hydraulic tandem pump
- A Suction line - oil reservoir to pressure pump
- HS Pressure line - hydraulic unit to ring cylinder
- T Return line - hydraulic unit to oil reservoir
- N Without leveling function:
Return line - hydraulic unit to oil reservoir
With leveling function:
Return line - leveling valve to oil reservoir
- P Pressure line - pressure pump to hydraulic unit
- Y38 ASD valve

P35-5882-57

Hydraulic Test Program - Component Locations

Hydraulic Components
Model 129.061

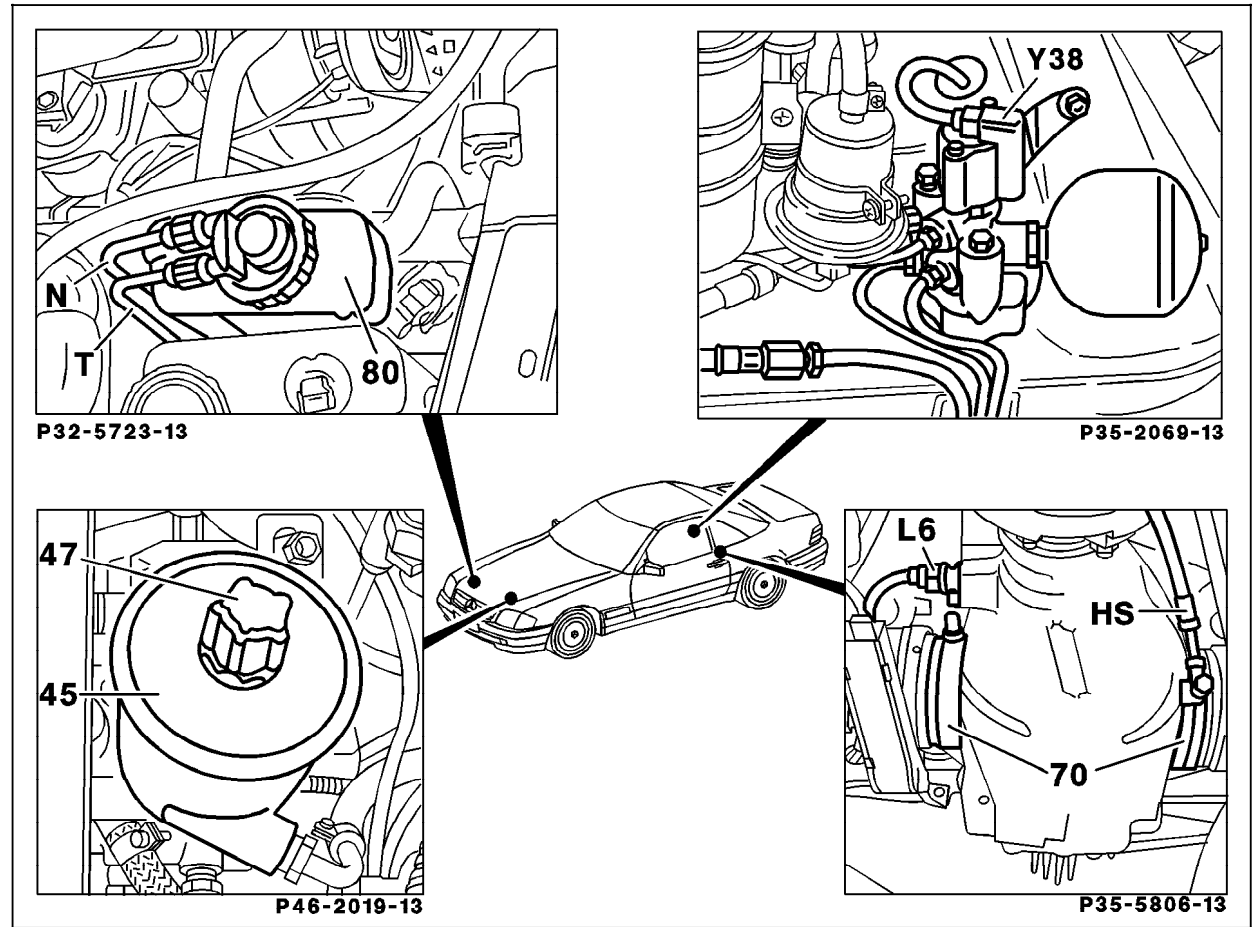

Figure 2

- 45 Tandem pump
- 70 Ring cylinder
- 80 Oil reservoir
- L6 Rear axle vehicle speed sensor
- Y38 ASD valve
- HS Pressure line - hydraulic unit to ring cylinder
- T Return line - hydraulic unit to oil reservoir
- N Without leveling function:
Return line - hydraulic unit to oil reservoir
With leveling function:
Return line - leveling valve to oil reservoir

P35-5884-57

Hydraulic Test Program - Component Locations

Hydraulic Components
Model 201.028

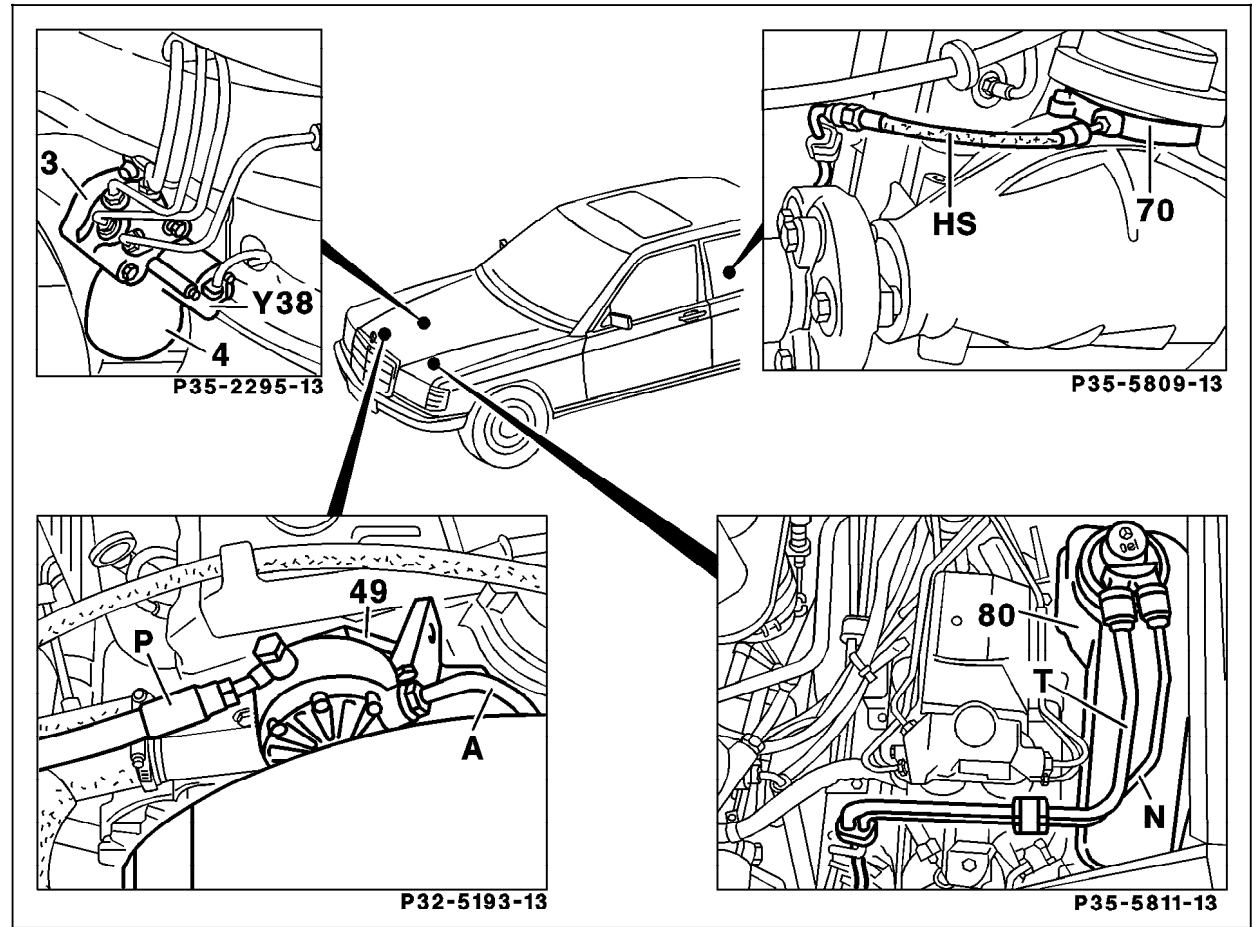

Figure 3

- 49 Hydraulic oil pump (camshaft driven)
- 3/4 Hydraulic unit with pressure reservoir
- 70 Ring cylinder
- 80 Oil reservoir
- A Suction line - oil reservoir to pressure pump
- HS Pressure line - hydraulic unit to ring cylinder
- T Return line - hydraulic unit to oil reservoir
- N Without leveling function:
Return line - hydraulic unit to oil reservoir
- With leveling function:
Return line - leveling valve to oil reservoir
- P Pressure line - pressure pump to hydraulic unit
- Y38 ASD valve

P35-5883-57

Hydraulic Test Program - Component Locations

Hydraulic Components
Model 201.029

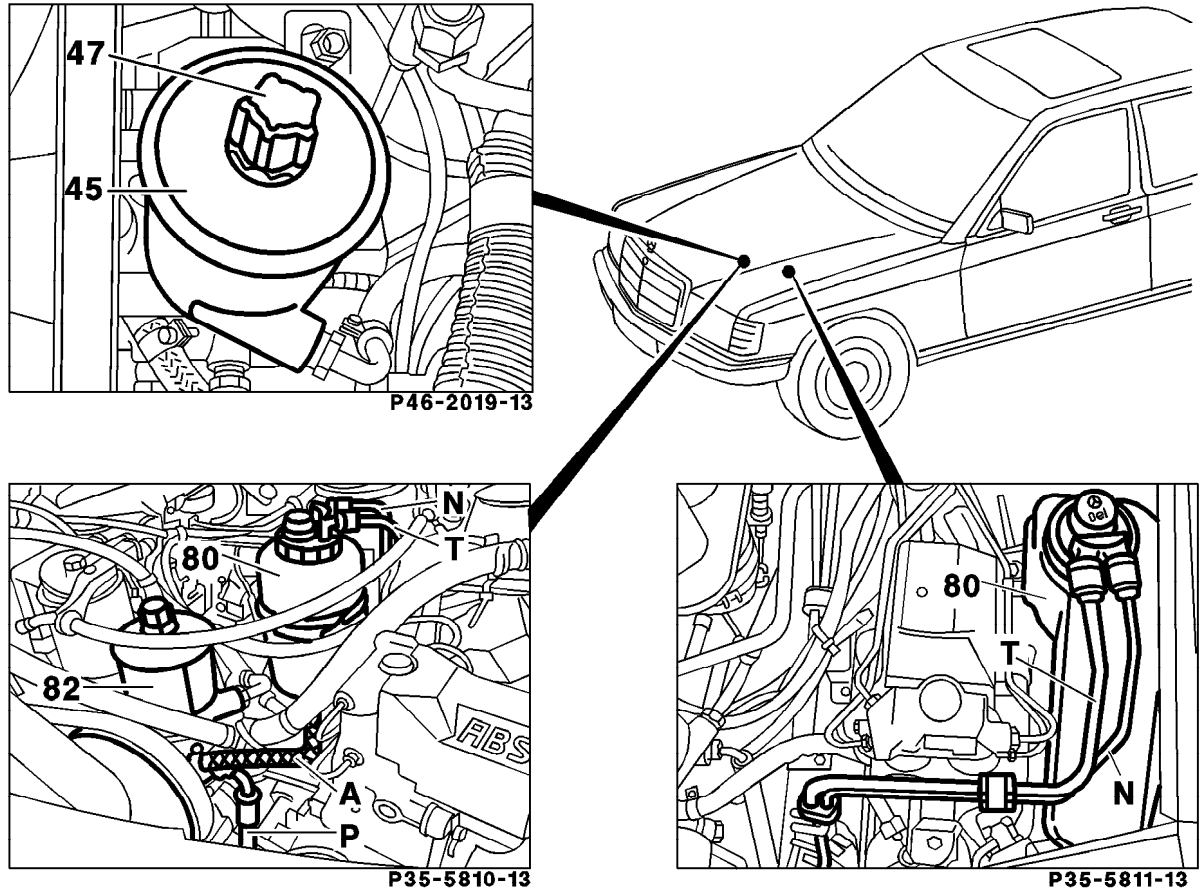

Figure 4

- 45 Tandem pump
- 80 Oil reservoir
- A Suction line - oil reservoir to pressure pump
- T Return line - hydraulic unit to oil reservoir
- N Without leveling function:
Return line - hydraulic unit to oil reservoir
- With leveling function:
Return line - leveling valve to oil reservoir
- P Pressure line - pressure pump to hydraulic unit

P35-5821-57