

Hydraulic Test Program - Preparation for Test

Preparation for Test

1. Ignition: **OFF**
2. Check oil level in oil reservoir, correct if necessary.
3. Release system pressure.
4. Connect the pressure gauge to pressure release screw on hydraulic unit according to connection diagram.

Note:

Checking hydraulic pump:

Model 129: 3.1 32 (ADS)

Model 124, 201: See SMS, Job No.
32-0530

Special Tools

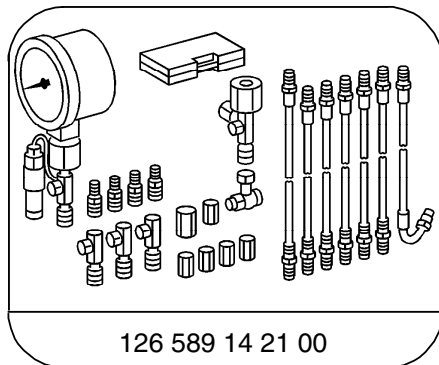

Tester

Hydraulic Test Program - Preparation for Test

Connection Diagram - Pressure Gauge

Shown on model 129

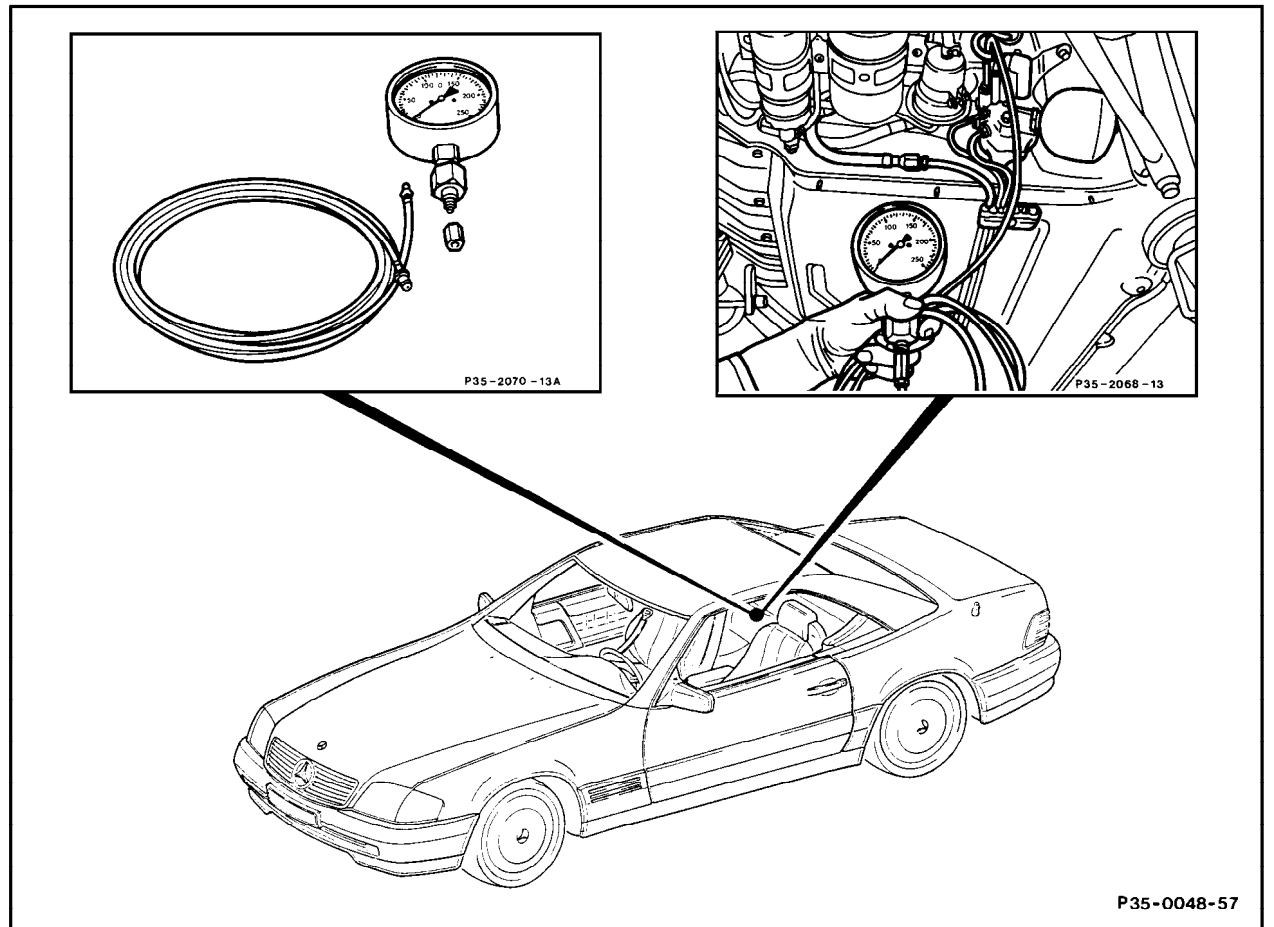

Figure 1

P35-0048-57

Hydraulic Test Program - Preparation for Test

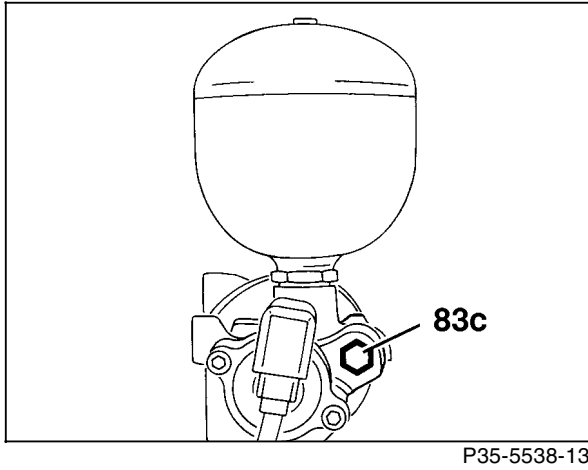

Figure 2

83c Closing screw