

Mechanical Test Program - Preparation for Test

Preparation for Test

1. Ignition: **OFF**
2. Check oil level in oil reservoir, correct if necessary.
3. Lift vehicle at rear on one side.
4. Attach frictional torque measurement adaptor plate (Figure 1) using two opposing wheel bolts on raised wheel. Screw studs with shorter threads into the rear axle shaft flange until they bottom out. Slide frictional torque measurement adaptor plate over studs and tighten knurled nuts by hand.
5. Disconnect ASD control module (N30/2).
6. Bridge sockets 8 and 10 of the ASD control module connector.

Special Tools

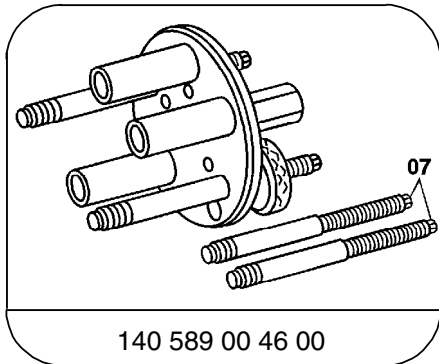

140 589 00 46 00

Drive flange

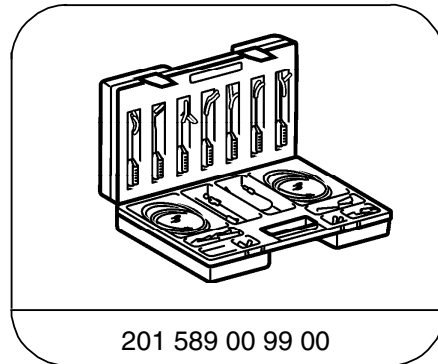

201 589 00 99 00

Electrical connecting set

Equipment

Torque Wrench
 Range: 16 – 65 Nm
 80 – 260 Nm

Local Purchase

Mechanical Test Program - Test

Frictional Torque Measurement
Shown on Model 201

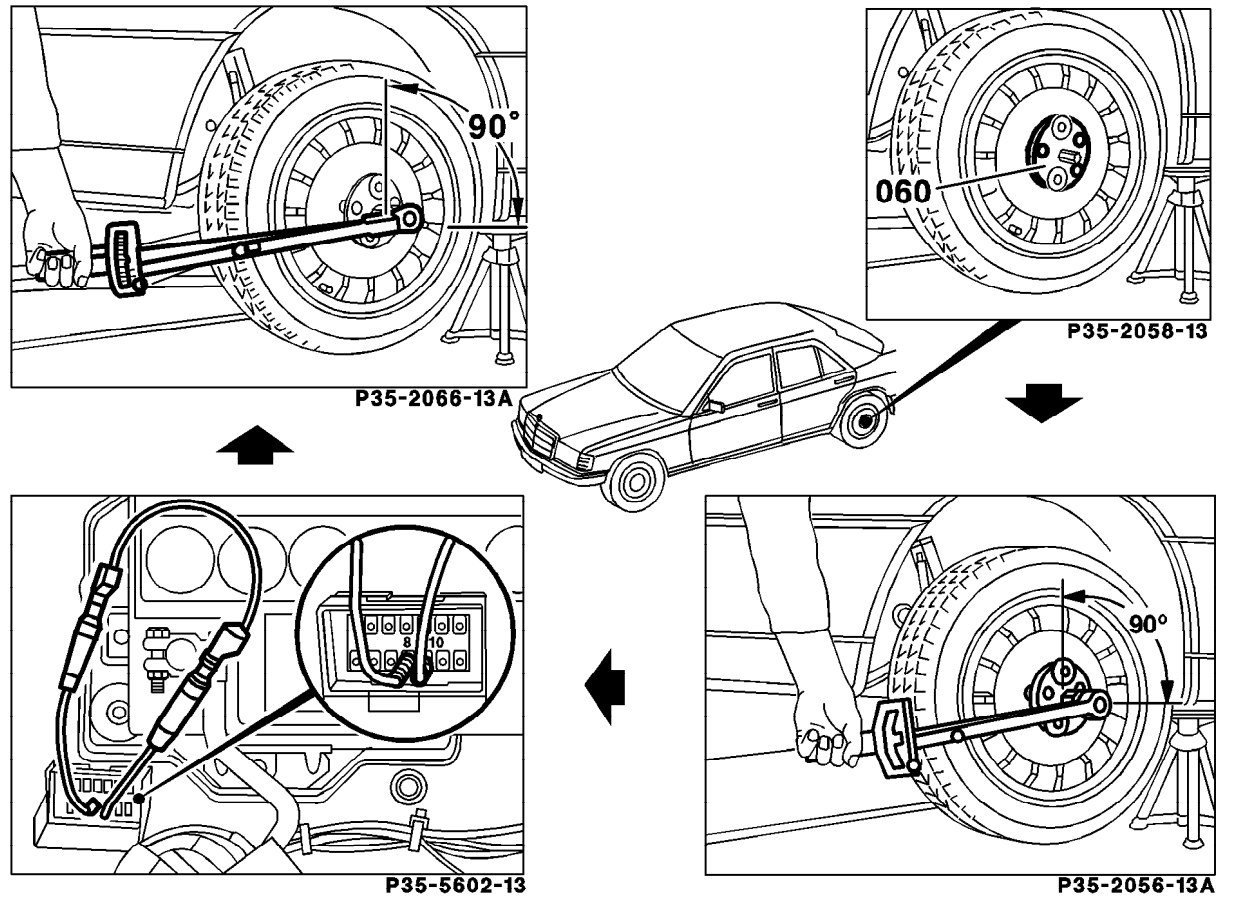

Figure 1
060 Frictional torque measurement adaptor plate

P35-5825-57