

Hydraulic Test Program - Component Locations

Hydraulic Components
Model 140 (→ 05/93)
ASD with pressure reservoir

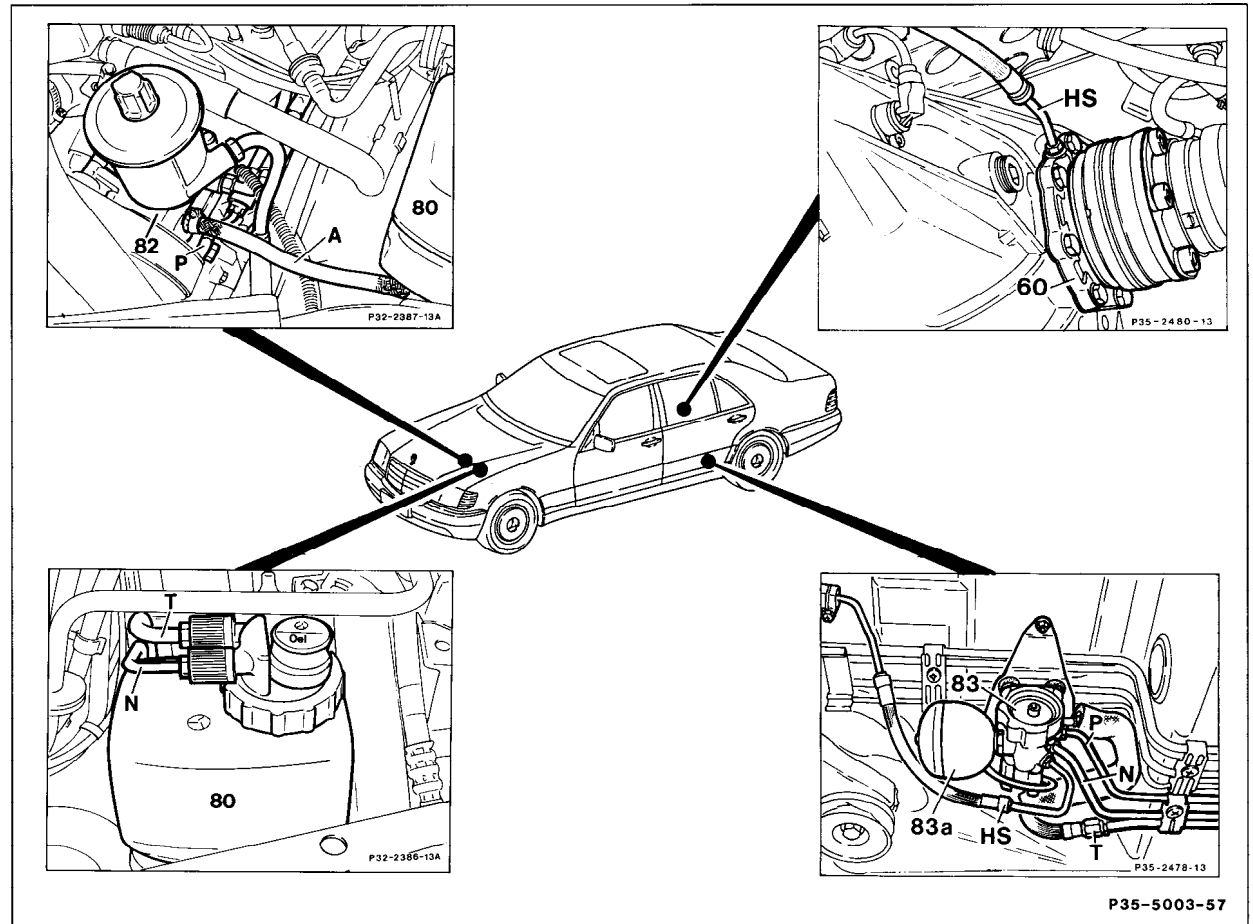

Figure 1

- 60 Side cover for bearing and ring cylinder
- 80 Oil reservoir
- 82 Hydraulic oil pump
- 83 Hydraulic unit
- 83a Pressure reservoir
- L6 Rear axle VSS sensor
- Y38 ASD valve
- A Suction line-from oil reservoir to pressure pump
- HS Pressure line from hydraulic unit to ring cylinder
- T Return line - hydraulic unit to oil reservoir
- N Without leveling function:
Return line - hydraulic unit to oil reservoir
With leveling function:
Return line - leveling valve to oil reservoir
- P Pressure line - pressure pump to hydraulic unit

P35-5003-57

Hydraulic Test Program - Component Locations

Hydraulic Components
 Model 140 (06/93 →)
 ASD without pressure reservoir

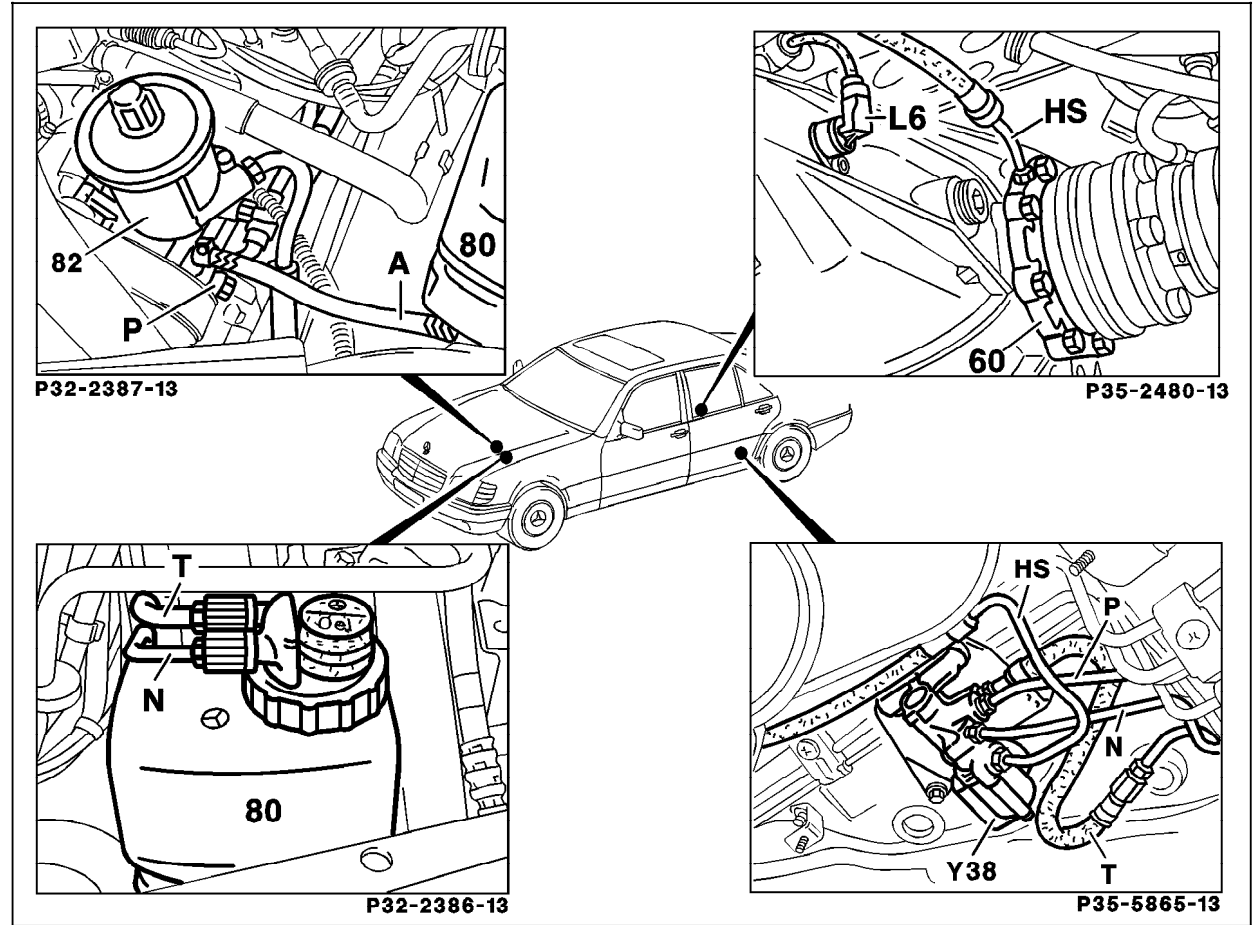

Figure 2

- 60 Side cover for bearing and ring cylinder
- 80 Oil reservoir
- 82 Hydraulic oil pump
- 83 Hydraulic unit without pressure reservoir
- L6 Rear axle VSS sensor
- Y38 ASD valve
- A Suction line-from oil reservoir to pressure pump
- HS Pressure line from hydraulic unit to ring cylinder
- T Return line - hydraulic unit to oil reservoir
- N Without leveling function:
 Return line - hydraulic unit to oil reservoir
 With leveling function:
 Return line - leveling valve to oil reservoir
- P Pressure line - pressure pump to hydraulic unit

P35-5864-57