

Electrical Test Program - Component Locations

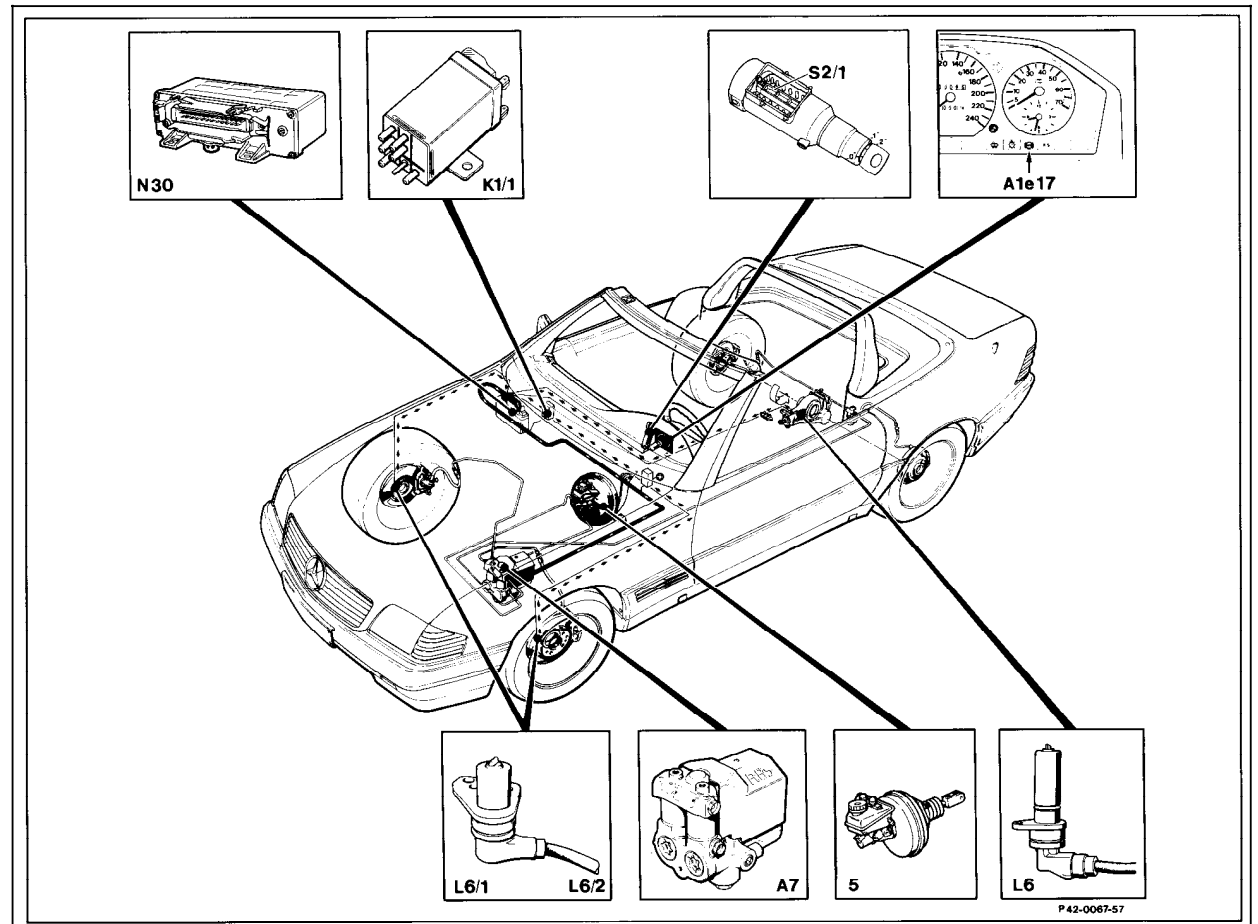

Figure 1

- 5 Brake booster with tandem master brake cylinder
- A1e17 ABS malfunction indicator lamp
- A7 ABS hydraulic unit
- K1/1 Overvoltage protection relay module (87E, 7-pole)
- L6 Rear axle vehicle speed sensor
- L6/1 Left front axle vehicle speed sensor
- L6/2 Right front axle vehicle speed sensor
- N30 ABS control module
- S2/1 Ignition/starter switch

P42-0067-57