

9.1 Models 129, 140 as of 06/94 up to 08/95

	Page
Diagnosis	
Function Test (ASR only)	11/1
Diagnostic Trouble Code (DTC) Memory	12/1
Complaint Related Diagnostic Chart	13/1
Electrical Test Program	
Component Locations	21/1
Preparation for Test	22/1
Test	23/1

Diagnosis - Function Test

Test step/Test scope	Test condition	Nominal value	Possible cause/Remedy ¹⁾
<p>⇒ 1.0 Brake torque control circuit</p>	<p>Lift rear of vehicle so that both rear wheels can be rotated freely. ⚠ Secure vehicle ! Engine: at Idle Selector lever in transmission range "D". Apply WOT using accelerator pedal.</p> <p>⚠ CAUTION! Should ASR not come into effect: Release accelerator pedal to idle speed.</p>	<p>The rear wheels are noticeably braked; simultaneously the high-pressure/return pump can audibly be heard operating. Engine speed is reduced to approx. 1000 rpm. The ASR warning lamp blinks.</p>	<p>23, DM, Engines, Vol. 3, sections 6.2 to 6.4.</p>
<p>⇒ 2.0 ASR off function using ASR OFF switch (S76/5)</p>	<p>Engine: at Idle Selector lever in "N". Press ASR OFF switch (S76/5).</p> <p>Selector lever in transmission range "D". Slowly depress accelerator pedal.</p>	<p>The ASR warning lamp illuminates.</p> <p>Engine speed is not reduced. The rear wheels are not braked. The ASR warning lamp blinks.</p>	<p>23 ⇒ 33.0</p>

1) Observe Preparation for Test, see 22.

Diagnosis - Diagnostic Trouble Code (DTC) Memory

Preparation for DTC Readout

1. Connect impulse counter scan tool or Hand-Held Tester (HHT) to data link connector (X11/4) according to connection diagram (see section 0).

Note:

Connect yellow wire from impulse counter scan tool to:

- | | |
|---|----------|
| ASR/SPS or ETS/SPS control module (N47-1, N47-2): | socket 6 |
| EA/CC/ISC control module (N4/1): | socket 7 |
| Base module (N16/1) | socket 8 |
| Engine control module (N3/4): | socket 4 |

- | | |
|---|-----------|
| LH-SFI or right LH-SFI control module (N3/1, N3/3): | socket 4 |
| Left LH-SFI control module (N3/2) | socket 5 |
| DI or right DI control module (N1/3, N1/5) | socket 17 |
| Left DI control module (N1/4) | socket 18 |

2. Ignition: **ON**
3. Read out DTC memory for control modules.

Special Tools

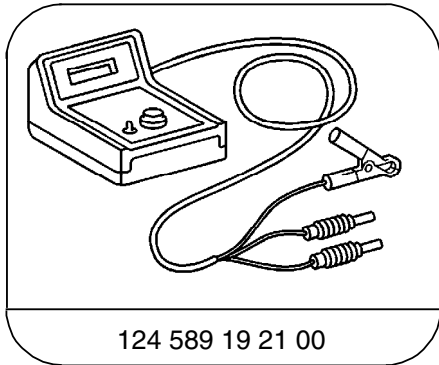

124 589 19 21 00

Pulse counter

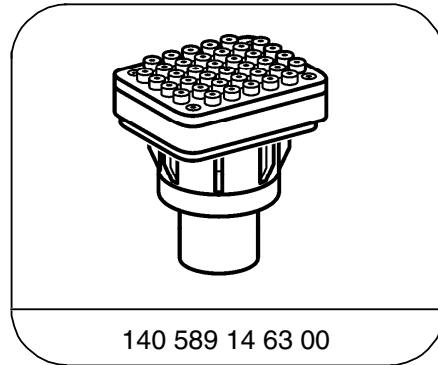

140 589 14 63 00

Adapter

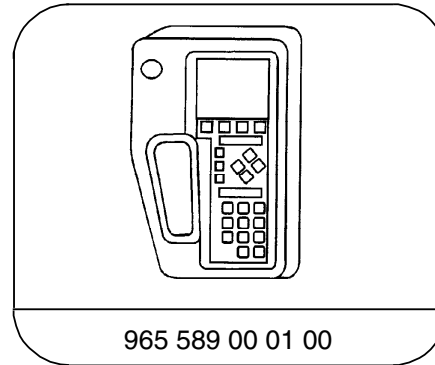

965 589 00 01 00

Hand-Held-Tester

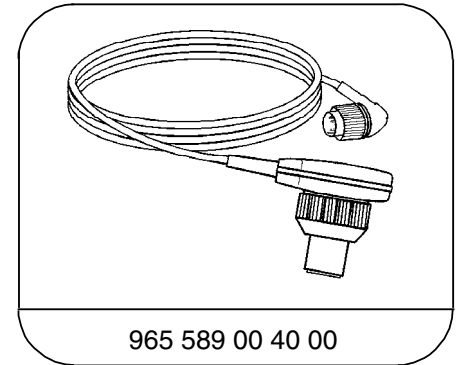

965 589 00 40 00

Test cable



Diagnosis - Diagnostic Trouble Code (DTC) Memory

DTC 	Possible cause	Test step/Remedy ¹⁾
1	No fault in system	In case of complaint: 23 (entire test), Check shorting pins as per D.D. topic 42A94091
2	ASR/SPS (N47-1) or ETS/SPS (N47-2) control module	Replace control module.
3	Left front axle VSS sensor (L6/1), open circuit	23 ⇒ 13.0
4	Right front axle VSS sensor (L6/2), open circuit	23 ⇒ 15.0
5	Left rear axle VSS sensor (L6/3), open circuit	23 ⇒ 17.0
6	Right rear axle VSS sensor (L6/4), open circuit	23 ⇒ 19.0
7	Left front axle VSS sensor (L6/1), implausible ²⁾	23 ⇒ 13.0
8	Right front axle VSS sensor (L6/2), implausible ²⁾	23 ⇒ 15.0
9	Left rear axle VSS sensor (L6/3), implausible ²⁾	23 ⇒ 17.0
10	Right rear axle VSS sensor (L6/4), implausible ²⁾	23 ⇒ 19.0
11	VSS (L6/1, L6/2, L6/3, L6/4), implausible ²⁾	23 ⇒ 13.0, 15.0, 17.0, 19.0 Visually inspect.
12	ASR/ETS/ESP hydraulic unit, solenoid valve relay (A7/3k1)	23 ⇒ 8.0
13	ASR/ETS/ESP hydraulic unit, left front axle solenoid valve (hold) (A7/3y6)	23 ⇒ 21.0
14	ASR/ETS/ESP hydraulic unit, left front axle solenoid valve (release) (A7/3y7)	23 ⇒ 22.0

1) Observe Preparation for Test, see 22.





2) Rotor with incorrect tooth count, dirt accumulation on or damaged rotor, incorrect rear axle ratio, wrong wheel or tire size.
If DTC appears only after repair work, it was caused by applying the brakes or driving vehicle on a dynamometer, erase DTC.

Diagnosis - Diagnostic Trouble Code (DTC) Memory

DTC 		Possible cause	Test step/Remedy ¹⁾
15	015	ASR/ETS/ESP hydraulic unit, right front axle solenoid valve (hold) (A7/3y8)	23 ⇒ 23.0
16	016	ASR/ETS/ESP hydraulic unit, right front axle solenoid valve (release) (A7/3y9)	23 ⇒ 24.0
17	017	ASR/ETS/ESP hydraulic unit, left rear axle solenoid valve (hold) (A7/3y10)	23 ⇒ 25.0
18	018	ASR/ETS/ESP hydraulic unit, left rear axle solenoid valve (release) (A7/3y11)	23 ⇒ 26.0
19	019	ASR/ETS/ESP hydraulic unit, right rear axle solenoid valve (hold) (A7/3y12)	23 ⇒ 27.0
20	020	ASR/ETS/ESP hydraulic unit, right rear axle solenoid valve (release) (A7/3y13)	23 ⇒ 28.0
21	021	ASR/ETS/ESP hydraulic unit, switchover/solenoid valve (A7/3y5)	23 ⇒ 30.0
22	022	ASR/ETS/ESP hydraulic unit, inlet solenoid valve (A7/3y15)	23 ⇒ 29.0
23	023	ASR only: ASR system pressure too low	ASR hydraulic unit (A7/3)
24	024	ASR/ETS/ESP hydraulic unit, high-pressure/return pump relay (A7/3k2)	23 ⇒ 9.0 High-pressure/return pump (A7/3m1)
27	027	Stop lamp switch (S9/1)	23 ⇒ 11.0
28	028	Battery voltage too low, circuit 87	23 ⇒ 1.0
29	029	ETS only: Circuit 30, voltage supply	23 ⇒ 2.0
30	030	ASR only: CAN data bus to EA/CC/ISC control module (N4/1) interrupted	23 ⇒ 35.0 Read out DTC, see DM, Engines, Vol. 3, sections 6.2 to 6.4 11.



¹⁾ Observe Preparation for Test, see 22.

Diagnosis - Diagnostic Trouble Code (DTC) Memory

DTC 	Possible cause	Test step/Remedy ¹⁾
31 	ASR only: CAN communication with LH-SFI or left and right LH-SFI control modules (N3/1 or N3/2 and N3/3) faulty CAN communication with engine control module (N3/4) faulty	23 ⇒ 35.0, Read out DTC, see DM, Engines, Vol. 2, section 3.1 11, or 3.2 11 or 1.1 11.
32 	ASR only: CAN communication with DI or left and right DI control module (N1/3 or N1/4 and N1/5) faulty	23 ⇒ 35.0, Read out DTC, see DM, Engines, Vol. 2, section 5.2 or 5.3 11.
33 	ASR only: CAN communication faulty in general	23 ⇒ 35.0, Read out DTC, see DM, Engines, Vol. 3, sections 6.2 to 6.4 11 (ASR). Read out DTC, see DM, Engines, Vol. 2, sections 5.2 or 5.3 11 (DI). Read out DTC, see DM, Engines, Vol. 2, sections 3.1 or 3.2 11 (LH-SFI). Read out DTC, see DM, Engines, Vol. 2, section 1.1 11 (HFM-SFI). Read out DTC, see DM, Chassis & Drivetrain, Vol. 1, section 2.2 12 (ETC).

1) Observe Preparation for Test, see 22.

Diagnosis - Diagnostic Trouble Code (DTC) Memory

DTC 		Possible cause	Test step/Remedy ¹⁾
34	034	ETS only: Brakes overheated	Brakes were momentarily overloaded, erase DTC.
35	035	Model 129.076, 140.04/05/07: Master brake cylinder switchover valve (Y61)	23 ⇒ 12.0
36	036	Model 129.076, 140.04/05/07: ABS lateral acceleration sensor (B24/2), open circuit	23 ⇒ 32.0
37	037	Model 129.076, 140.04/05/07: ABS lateral acceleration sensor (B24/2), implausible	23 ⇒ 32.0
38	038	ETS only: ETS/SPS control module (N47-2) not coded	Input code data into control module with HHT.
39	039	Model 140: ASR/SPS or ETS/SPS control module (N47-1 or N47-2)	Replace control module.
40	040	Model 140: SPS P-valve (Y10)	23 ⇒ 31.0
41	041	Model 140: ASR/SPS or ETS/SPS control module (N47-1 or N47-2)	Replace control module.

1) Observe Preparation for Test, see 22.

Diagnosis - Complaint Related Diagnostic Chart

Complaint/Problem	Possible cause	Test step/Remedy ¹⁾
ASR MIL (A1e22) or ETS MIL (A1e35) and ABS MIL (A1e17) come when engine is running		Check voltage supply and ground, Read DTC memory 12, DM, Chassis & Drivetrain, Vol. 1, section 1.1 11
ETS MIL (A1e35) comes on while driving and after a while goes out	Rear axle brakes were momentarily overloaded.	Read DTC memory 12, Erase DTC 334
ASR MIL (A1e22) or ETS MIL (A1e35) and ABS MIL (A1e17) comes on while driving and does not go out		Read DTC memory 12
ASR MIL (A1e22) or ETS MIL (A1e35) and ABS MIL (A1e17) comes on while driving and then goes out	Vehicle system voltage < 11 V, too many electrical consumers in use.	Check voltage supply and ground, Check generator (G2), Read DTC memory 12
ABS MIL (A1e17) does not come on with ignition turned on		23 ⇒ 3.0
ASR MIL (A1e22) or ETS MIL (A1e35) does not come on with ignition turned on		23 ⇒ 4.0
ABS MIL (A1e17) comes on with engine running after brake test or dynamometer use	Implausible rpm signal due to different rpm at front and rear axles.	Read, erase DTC memory 12

1) Observe Preparation for Test, see 22.

Electrical Test Program - Component Locations

Figure 1

- A1e17 ABS MIL
- A7/3k1 ASR/ETS/ESP hydraulic unit, solenoid valve relay
- A7/3k2 ASR/ETS/ESP hydraulic unit, high-pressure/return pump relay
- A7/3m1 ASR/ETS/ESP hydraulic unit, high-pressure/return pump
- L6/1 Left front axle VSS sensor
- L6/2 Right front axle VSS sensor
- L6/3 Left rear axle VSS sensor
- L6/4 Right rear axle VSS sensor
- N16/1 Base module
- S9/1 Stop lamp switch
- X11/4 Data link connector

ASR only

- A1e21 ASR warning lamp
- A1e22 ASR MIL
- N47-1 ASR/SPS control module
- S12 Parking brake switch
- S76/5 ASR OFF switch
- Y61 Master brake cylinder switchover valve (Models 129.076, 140.04/05/07)

ETS only

- A1e35 ETS MIL
- A1e36 ETS warning lamp
- N47-2 ETS/SPS control module

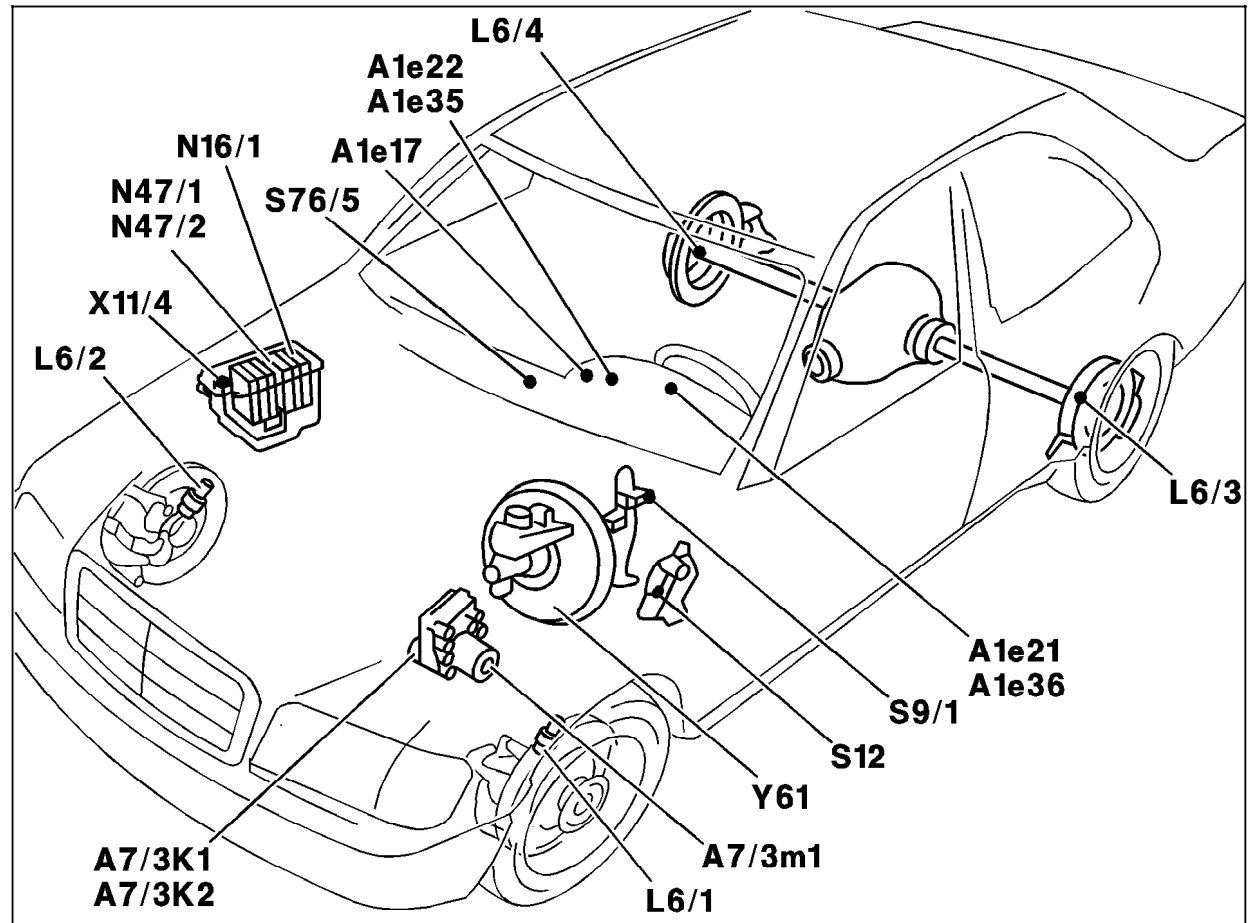

P42-5312-57

Electrical Test Program - Preparation for Test

1. Ignition: **OFF**
2. Disconnect ASR/SPS or ETS/SPS control module (N47-1 or N47-2).
3. Connect socket box with test cable as per connection diagram (Figure 1).

Note:
The measured voltages will be slightly lower in diesel models during preglow.

Electrical Wiring Diagrams:

Electrical Troubleshooting Manual, Model 129,
Electrical Troubleshooting Manual, Model 140.



When exchanging an ETS/SPS control module, the replacement module must have the code data entered via the HHT. Follow instructions on HHT display.

Special Tools

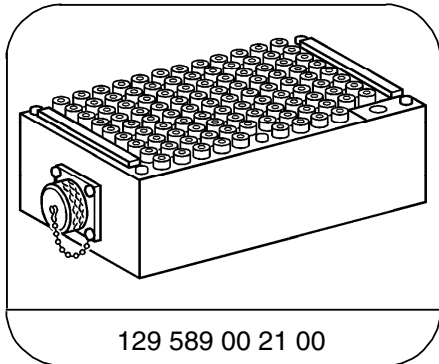

129 589 00 21 00

126-pin socket box

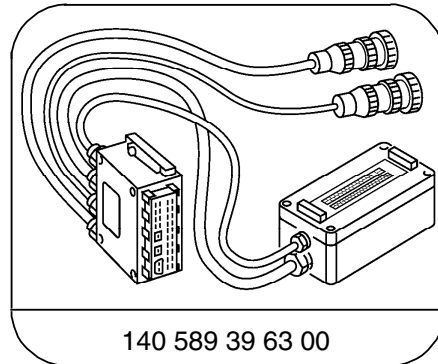

140 589 39 63 00

Test cable for module 6

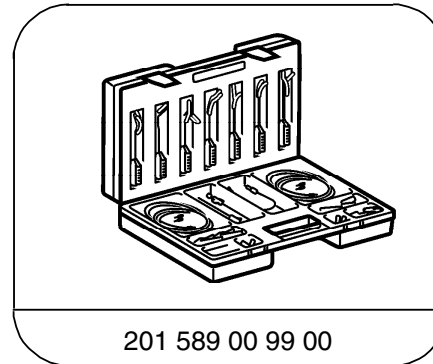

201 589 00 99 00

Electrical connecting set

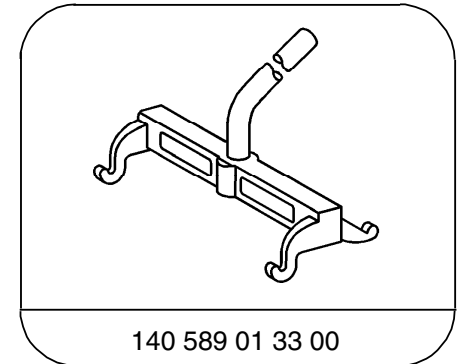

140 589 01 33 00

Mounting lever

Conventional tools, test equipment

Description	Brand, model, etc.
Digital multimeter ¹⁾	Fluke models 23, 83, 85, 87

¹⁾ Available through the MBUSA Standard Equipment Program.

Electrical Test Program - Preparation for Test

Connection Diagram – Socket Box

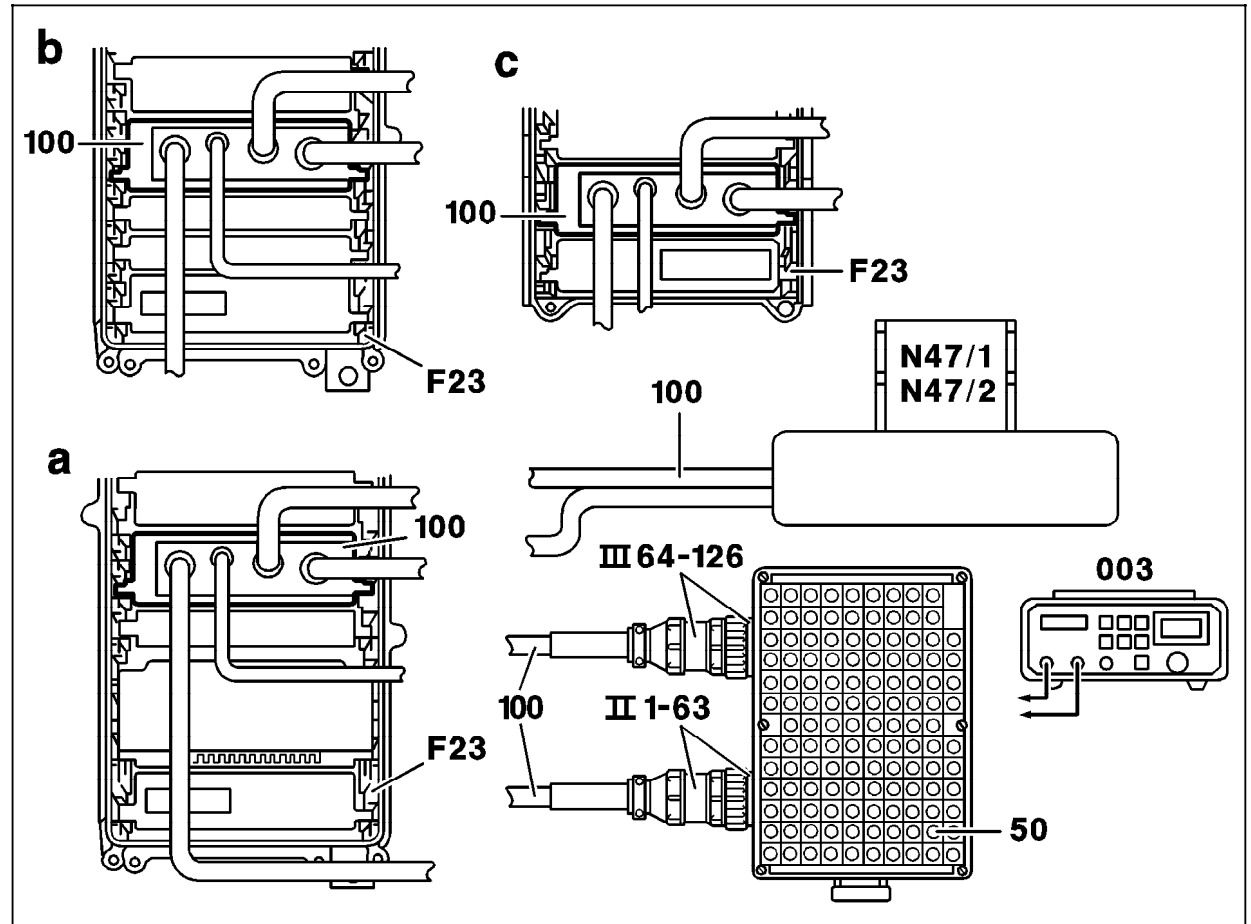

Figure 1



- 003 Digital multimeter
- 050 Socket box, 126-pole
- 100 Test cable, 140 589 39 63 00
- F23 Module box
- N47-1 ASR/SPS control module
- N47-2 ETS/SPS control module

Location of control module in module box



- a Model 140 with HFM-SFI
- b Model 140 with LH-SFI
- c Model 129

P42-5310-57

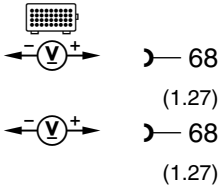
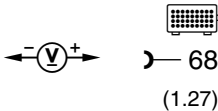
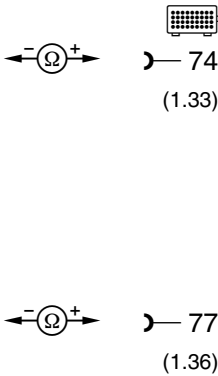

Electrical Test Program - Test

⇒		Test scope	Test connection	Test condition	Nominal value	Possible cause/Remedy
1.0		ASR/SPS or ETS/SPS control module (N47-1 or N47-2) Circuit 87 Voltage supply	N47-1 N47-2 	Ignition: ON	11 – 14 V	⇒ 1.1, ⇒ 1.2
1.1		Voltage supply from base module (N16/1)		Ignition: ON	11 – 14 V	Fuse (F1) on N16/1, DM, Chassis & Drivetrain, Vol. 1, sections 1.1 or 1.2 23, Wiring.
1.2		Ground wire	N47-1 N47-2 	Ignition: OFF Control module (N47-1 or N47-2) disconnected. Disconnect ground wire.	< 1 Ω	Model 129 Wiring, Ground (module box bracket) (W27). Model 140 Wiring, Ground (electronics output ground - right footwell) (W15).

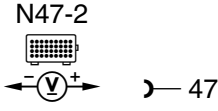
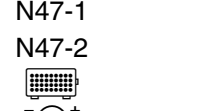
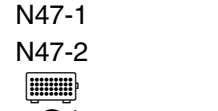



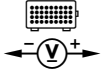
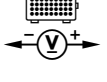

Electrical Test Program - Test

⇒		Test scope	Test connection	Test condition	Nominal value	Possible cause/Remedy
2.0 ETS only		ETS/SPS control module (N47-2) Circuit 30 Voltage supply	<div style="text-align: center;">  <p>N47-2</p> </div>	Ignition: OFF	11 – 14 V	Wiring.
3.0		ABS MIL (A1e17)	<div style="text-align: center;">  <p>N47-1 N47-2</p> </div>	Ignition: ON Engine: at Idle	< 2 V A1e17: ON 10 – 14 V A1e17: OFF	A1e17. Read DTC memory 12, Wiring, N47-1 or N47-2.
4.0		ASR MIL or ETS MIL (A1e22 or A1e35)	<div style="text-align: center;">  <p>N47-1 N47-2</p> </div>	Ignition: ON Engine: at Idle	< 2 V A1e22 or A1e35: ON 10 – 14 V A1e22 or A1e35: OFF	A1e22 or A1e35. Read DTC memory 12, Wiring, N47-1 or N47-2.







Electrical Test Program - Test

⇒		Test scope	Test connection	Test condition	Nominal value	Possible cause/Remedy
5.0		ASR or ETS warning lamp (A1e21 or A1e36)	<p>N47-1 N47-2</p>  <p>74 —((1.33) —) 57 (1.16)</p>	<p>Ignition: ON</p> <p>Engine: at Idle</p>	<p>< 2 V A1e21 or A1e36: ON</p> <p>10 – 14 V A1e21 or A1e36: OFF</p>	<p>Wiring, A1e21 or A1e36.</p> <p>Wiring.</p>
6.0		Diagnosis output	<p>N47-1 N47-2</p>  <p>74 —((1.33) —) 53 (1.12)</p>	<p>Ignition: ON</p>	<p>10 – 14 V</p>	<p>Wiring, N47-1 or N47-2.</p>
7.0		Circuit 61 Voltage supply		<p>Ignition: ON</p> <p>Engine: at Idle</p>	<p>OFF</p> <p>ON</p>	<p>Wiring, Generator (G2).</p>



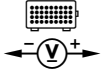
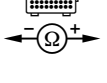







Electrical Test Program - Test

⇒		Test scope	Test connection	Test condition	Nominal value	Possible cause/Remedy
8.0		ASR/ETS/ESP hydraulic unit, solenoid valve relay (A7/3k1) Voltage supply Control	N47-1 N47-2  N47-1 N47-2 	Ignition: ON	11 – 14 V	12, Wiring, ⇒ 8.1
8.1		Coil resistance	N47-1 N47-2 	Ignition: OFF Control module (N47-1 or N47-2) disconnected.	40 – 80 Ω	Wiring, A7/3k1, ⇒ 8.2
8.2		Working contact	N47-1 N47-2 	Ignition: ON	11 – 14 V	Wiring, A7/3k1.

Electrical Test Program - Test

⇒		Test scope	Test connection	Test condition	Nominal value	Possible cause/Remedy
9.0		ASR/ETS/ESP hydraulic unit, high-pressure/return pump relay (A7/3k2) Voltage supply	N47-1 N47-2 	Ignition: ON	11 – 14 V	Wiring, ⇒ 9.1
9.1		Coil resistance	N47-1 N47-2 	Ignition: OFF Control module (N47-1 or N47-2) disconnected.	40 – 80 Ω	Wiring, A7/3k2.
10.0		Parking brake switch (S12)		Engine: at Idle Apply parking brake. Release parking brake.	 Parking brake indicator lamp (A1e7): ON  A1e7: OFF	Wiring, S12, A1e7.

Electrical Test Program - Test

⇒		Test scope	Test connection	Test condition	Nominal value	Possible cause/Remedy
11.0		Stop lamp switch (S9/1) N.O. contact N.C. contact		Ignition: ON Brakes not applied. Brakes applied. Brakes not applied. Brakes applied.	OFF ON OFF ON	Wiring, S9/1.
12.0		Models 129.076, 140.04/05/07 Master brake cylinder switchover valve (Y61) Internal resistance	1 —  — 2	Ignition: OFF Pull connector off of Y61.	7 – 8 Ω	Y61.
13.0	  	Left front axle VSS sensor (L6/1)		Raise front of vehicle. Ignition: ON Rotate left front tire by hand (> 1 rev./sec.).	> 2 mph (3 km/h)	⇒ 13.1, ⇒ 13.2
13.1		Internal resistance	N47-1 N47-2  10 —  — 30 (2.10) (2.30)	Ignition: OFF Control module (N47-1 or N47-2) disconnected.	0.8 – 2.3 kΩ	Wiring, L6/1.





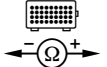
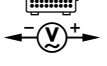
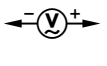
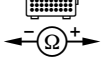
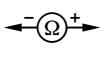

Electrical Test Program - Test

⇒		Test scope	Test connection	Test condition	Nominal value	Possible cause/Remedy
13.2		Insulation resistance	<p>N47-1 N47-2</p>	Ignition: OFF Control module (N47-1 or N47-2) disconnected.	> 20 kΩ	Wiring, L6/1.
14.0		Left front axle VSS sensor (L6/1) output	<p>N47-1 N47-2</p>	Raise front of vehicle. Ignition: ON Rotate left front tire by hand (> 1 rev./sec.).	> 3 V	Wiring, ⇒ 14.1, N47-1 or N47-2.
14.1		Load with control modules connected	<p>N47-1 N47-2</p>	Ignition: OFF Control module (N47-1 or N47-2) disconnected.	> 5 kΩ	Wiring, Connected control modules (N4/1, N4/2, N22, etc.), ⇒ 13.0
15.0		Right front axle VSS sensor (L6/2)		Raise front of vehicle. Ignition: ON Rotate right front tire by hand (> 1 rev./sec.).	> 2 mph (3 km/h)	⇒ 15.1, ⇒ 15.2
15.1		Internal resistance	<p>N47-1 N47-2</p>	Ignition: OFF Control module (N47-1 or N47-2) disconnected.	0.8 – 2.3 kΩ	Wiring, L6/2.



Electrical Test Program - Test

⇒		Test scope	Test connection	Test condition	Nominal value	Possible cause/Remedy
15.2		Insulation resistance	<p>N47-1 N47-2</p>  <p>74 — (1.33) 13 — (2.13)</p>	Ignition: OFF Control module (N47-1 or N47-2) disconnected.	> 20 kΩ	Wiring, L6/2.
16.0		Right front axle VSS sensor (L6/2) output	<p>N47-1 N47-2</p> <p>ASR</p>  <p>74 — (1.33) 44 — (1.3)</p> <p>ETS</p>  <p>74 — (1.33) 65 — (1.24)</p>	Raise front of vehicle. Ignition: ON Rotate right front tire by hand (> 1 rev./sec.).	> 3 V	Wiring, ⇒ 16.1, N47-1 or N47-2.
16.1		Load with control modules connected	<p>N47-1 N47-2</p> <p>ASR</p>  <p>74 — (1.33) 44 — (1.3)</p> <p>ETS</p>  <p>74 — (1.33) 65 — (1.24)</p>	Ignition: OFF control module (N47-1 or N47-2) disconnected.	> 5 kΩ	Wiring, Connected control modules (N16/1, N51, etc.), ⇒ 15.0



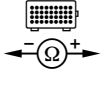
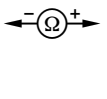

Electrical Test Program - Test

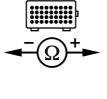
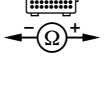
⇒		Test scope	Test connection	Test condition	Nominal value	Possible cause/Remedy
17.0	005 009 011	Left rear axle VSS sensor (L6/3)		Raise rear of vehicle. Ignition: ON Rotate left rear tire by hand (> 1 rev./sec.).	> 2 mph (3 km/h)	⇒ 17.1, ⇒ 17.2
17.1		Internal resistance	N47-1 N47-2  73 — Ω — 72 (1.32) (1.31)	Ignition: OFF Control module (N47-1 or N47-2) disconnected.	0.6 – 1.8 kΩ	Wiring, L6/3.
17.2		Insulation resistance	N47-1 N47-2  74 — Ω — 73 (1.33) (1.32)	Ignition: OFF Control module (N47-1 or N47-2) disconnected.	> 20 kΩ	Wiring.
18.0		Left rear axle VSS sensor (L6/3) output	N47-1 N47-2  ASR 74 — V — 66 (1.33) (1.25)  ETS 74 — V — 58 (1.33) (1.17)	Raise rear of vehicle. Ignition: ON Rotate left rear tire by hand (> 1 rev./sec.).	> 3 V	Wiring, ⇒ 18.1, N47-1 or N47-2.



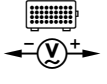
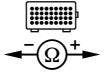

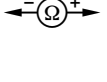



Electrical Test Program - Test

⇒		Test scope	Test connection	Test condition	Nominal value	Possible cause/Remedy
18.1		Load with control modules connected	<p>N47-1 N47-2</p> <p>ASR</p>  <p>ETS</p> 	Ignition: OFF Control module (N47-1 or N47-2) disconnected.	> 5 kΩ	Wiring, Connected control modules (N3/4, N4/1, etc.), ⇒ 17.0
19.0		Right rear axle VSS sensor (L6/4)		Raise rear of vehicle. Ignition: ON Rotate right rear tire by hand (> 1 rev./sec.).	> 2 mph (3 km/h)	⇒ 19.1, ⇒ 19.2
19.1		Internal resistance	<p>N47-1 N47-2</p> 	Ignition: OFF Control module (N47-1 or N47-2) disconnected.	0.6 – 1.8 kΩ	Wiring, L6/4.
19.2		Insulation resistance	<p>N47-1 N47-2</p> 	Ignition: OFF Control module (N47-1 or N47-2) disconnected.	> 20 kΩ	Wiring, L6/4.

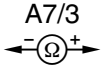

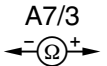

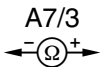

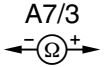

Electrical Test Program - Test

⇒		Test scope	Test connection	Test condition	Nominal value	Possible cause/Remedy
20.0		Right rear axle VSS sensor (L6/4) output	<p>N47-1 N47-2</p>  <p>74 — (1.33) — 67 (1.26)</p>	<p>Raise rear of vehicle. Ignition: ON Rotate right rear tire by hand (> 1 rev./sec.).</p>	> 3 V	⇒ 20.1, N47-1 or N47-2.
20.1		Load with control modules connected	<p>N47-1 N47-2</p>  <p>74 — (1.33) — 67 (1.26)</p>	<p>Ignition: OFF Control module (N47-1 or N47-2) disconnected.</p>	> 5 kΩ	Wiring, Connected control modules (N3/4, N4/1, etc.), ⇒ 19.0
21.0		ASR/ETS/ESP hydraulic unit, left front axle solenoid valve (hold) (A7/3y6) Internal resistance	<p>A7/3</p>  <p>1 — — 12</p>	<p>Ignition: OFF Disconnect electrical connector on A7/3.</p>	5.4 – 12.6 Ω	Wiring, A7/3.
22.0		ASR/ETS/ESP hydraulic unit, left front axle solenoid valve (release) (A7/3y7) Internal resistance	<p>A7/3</p>  <p>1 — — 13</p>	<p>Ignition: OFF Disconnect electrical connector on A7/3.</p>	2.8 – 6.6 Ω	Wiring, A7/3.

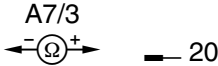

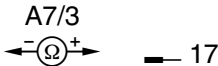

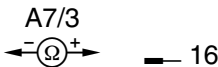

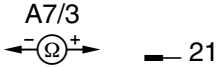
Electrical Test Program - Test

⇒		Test scope	Test connection	Test condition	Nominal value	Possible cause/Remedy
23.0		ASR/ETS/ESP hydraulic unit, right front axle solenoid valve (hold) (A7/3y8) Internal resistance	1 —  — 3	Ignition: OFF Disconnect electrical connector on A7/3.	5.4 – 12.6 Ω	Wiring, A7/3.
24.0		ASR/ETS/ESP hydraulic unit, right front axle solenoid valve (release) (A7/3y9) Internal resistance	1 —  — 14	Ignition: OFF Disconnect electrical connector on A7/3.	2.8 – 6.6 Ω	Wiring, A7/3.
25.0		ASR/ETS/ESP hydraulic unit, left rear axle solenoid valve (hold) (A7/3y10) Internal resistance	1 —  — 19	Ignition: OFF Disconnect electrical connector on A7/3.	5.4 – 12.6 Ω	Wiring, A7/3.
26.0		ASR/ETS/ESP hydraulic unit, left rear axle solenoid valve (release) (A7/3y11) Internal resistance	1 —  — 18	Ignition: OFF Disconnect electrical connector on A7/3.	2.8 – 6.6 Ω	Wiring, A7/3.



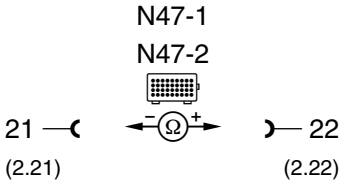



Electrical Test Program - Test

⇒		Test scope	Test connection	Test condition	Nominal value	Possible cause/Remedy
27.0		ASR/ETS/ESP hydraulic unit, right rear axle solenoid valve (hold) (A7/3y12) Internal resistance	1 —  20	Ignition: OFF Disconnect electrical connector on A7/3.	5.4 – 12.6 Ω	Wiring, A7/3.
28.0		ASR/ETS/ESP hydraulic unit, right rear axle solenoid valve (release) (A7/3y13) Internal resistance	1 —  17	Ignition: OFF Disconnect electrical connector on A7/3.	2.8 – 6.6 Ω	Wiring, A7/3.
29.0		ASR/ETS/ESP hydraulic unit, inlet solenoid valve (A7/3y15) Internal resistance	1 —  16	Ignition: OFF Disconnect electrical connector on A7/3.	5.4 – 12.6 Ω	Wiring, A7/3.
30.0		ASR/ETS/ESP hydraulic unit, switchover/solenoid valve (A7/3y5) Internal resistance	1 —  21	Ignition: OFF Disconnect electrical connector on A7/3.	5.4 – 12.6 Ω	Wiring, A7/3.

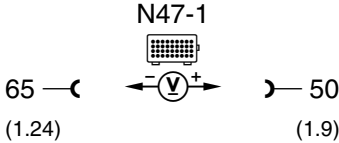
Electrical Test Program - Test

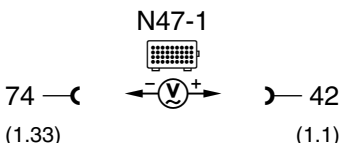
⇒		Test scope	Test connection	Test condition	Nominal value	Possible cause/Remedy
31.0		Model 140 SPS P-valve (Y10) Voltage supply		Engine: at Idle Press MAX key Press MIN key	> 800 mA steering is light < 400 mA steering is heavy	⇒ 31.1, N47-1 or N47-2.
31.1		Coil resistance	N47-1 N47-2 	Ignition: OFF Control module (N47-1 or N47-2) disconnected.	3 – 8 Ω	Wiring, Y10.
32.0	 	Models 129.076, 140.04/05/07 ABS lateral accelration sensor (B24/2) Static sensor signal (off) Dynamic sensor signal (on)		Vigorously rock vehicle from side to side.	0±1 m/s ² > 1 m/s ² Value changes with movement of vehicle	Wiring, B24/2, ⇒ 32.1

Electrical Test Program - Test

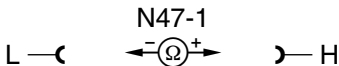
⇒		Test scope	Test connection	Test condition	Nominal value	Possible cause/Remedy
32.1		Voltage supply to sensor input	<p>N47-1</p> 	Ignition: ON Disconnect connector on B24/2.	4.75–5.25 V	Wiring, N47-1.
33.0 ASR only		ASR OFF switch (S76/5)		Press and hold switch S76/5: ON Release switch Press and hold switch S76/5: OFF	1 – 2 V 3.5 – 6 V < 1 V	Wiring, S76/5, N47-1.
34.0		VSS sensor output status Signal: Vehicle stationary	<p>N47-1</p> 	Engine: at Idle	> 3 V	⇒ 34.1
35.0 ASR only	   	CAN bus	<p>N47-1</p> 	Ignition: OFF Disconnect contact module 2 or N47-1. Test directly at both wide connectors using an ohmmeter.	55 – 65 Ω	Data bus, ⇒ 35.1, ⇒ 35.2

Electrical Test Program - Test

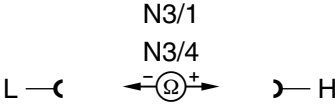
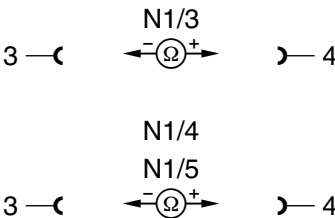
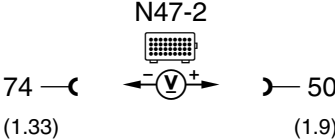
⇒		Test scope	Test connection	Test condition	Nominal value	Possible cause/Remedy
35.1		Engine 104, 119 CAN element in LH-SFI or engine control module (N3/1 or N3/4) Resistance		Disconnect control module (N3/1 or N3/4) and test directly on control module using an ohmmeter.	115 – 125 Ω	N3/1 or N3/4, DM, Engines, Vol. 2, sections 3.1 or 1.1 23.
35.2		CAN element in DI control module (N1/3, N1/4 or N1/5) Resistance Engine 104/119 LH-SFI Engine 120		Disconnect connector B on control module (N1/3, N1/4 or N1/5) and test directly on control module using an ohmmeter.	115 – 125 Ω	Engine 104/119 LH-SFI N1/3, DM, Engines, Vol. 2, section 5.2 23. Engine 120 N1/4 or N1/5, DM, Engines, Vol. 2, section 5.3 23.
36.0 ETS only		ETS signal		Ignition: ON Engine: at Idle	< 1 V ETS MIL (A1e35): ON 10 – 14 V A1e35: OFF	Wiring, N47-2.

Electrical Test Program - Test

Connector Layout - Connector 1
(interior harness)
ASR/SPS or ETS/SPS control module
(N47-1 or N47-2)

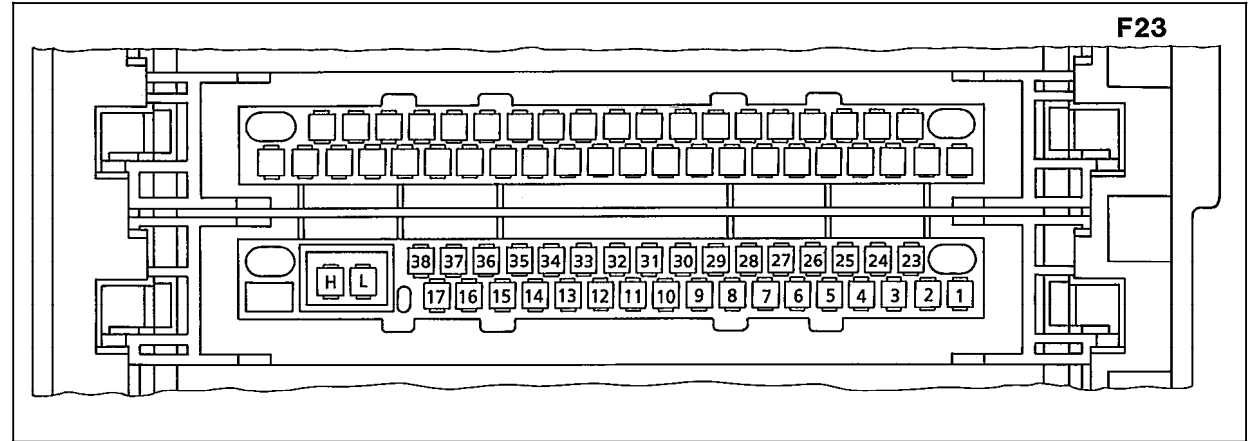

P07-5171-53

1	VSS sensor output status	15	not used	30	Right rear axle VSS sensor (L6/4) (-)
2	not used	16	ASR or ETS warning lamp (A1e21 or A1e36)	31	Left rear axle VSS sensor (L6/3) (+)
3	ASR: Right front axle VSS sensor (L6/2) output	17	ASR: Models 129.076, 140.04/05/07	32	Left rear axle VSS sensor (L6/3) (-)
4	ETS: Stop lamp switch (S9/1), N.C. contact		ASR lateral acceleration sensor (B24/2) signal	33	Ground
5	ASR: Stop lamp switch (S9/1), N.C. contact		ETS: Left rear axle VSS sensor (L6/3) output		Model 140: W15
6	ASR: Circuit 61 voltage	18-22	not used		Model 129: W27
	ETS: Circuit 30 voltage	23	Left front axle VSS sensor (L6/1) output	34	not used
7	ASR: ASR Off switch (S76/5)	24	ASR: Models 129.076, 140.04/05/07	35	ABS MIL (A1e17)
8	ASR: Stop lamp switch (S9/1) N.O. contact		ASR lateral acceleration sensor (B24/2) (-)	36	Ground
9	ASR: Models 129.076, 140.04/05/07		ETS: Right front axle VSS sensor (L6/2) output		W16/1 or W27
	ASR lateral acceleration sensor (B24/2) (+)	25	ASR: Left rear axle VSS sensor (L6/3) output	37	not used
	ETS: ETS signal		ETS: Circuit 61 voltage	38	ASR or ETS MIL (A1e22 or A1e35)
10-11	not used	26	Right rear axle VSS sensor (L6/4) output	H	ASR: CAN bus (+)
12	Diagnosis output to DLC (X11/4)	27	Circuit 87 voltage	L	ASR: CAN bus (-)
13	not used	28	ETS: Stop lamp switch (S9/1) N.O. contact		
14	ASR: Parking brake switch (S12)	29	Right rear axle VSS sensor (L6/4) (+)		

Electrical Test Program - Test

Connector Layout - Connector 2
(engine harness)
ASR/SPS or ETS/SPS control module
(N47-1 or N47-2)

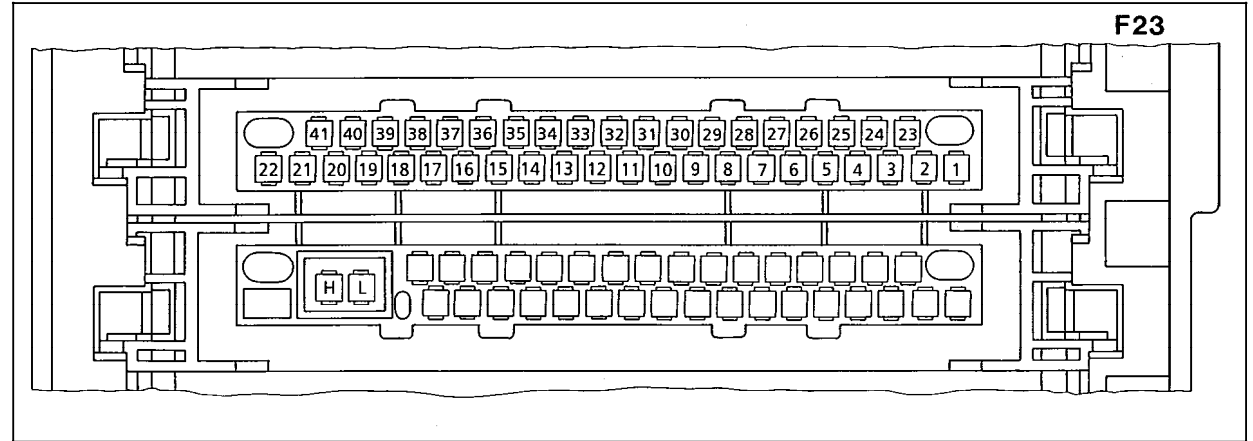

P07-5170-53

1	not used	17	ASR/ETS hydraulic unit, inlet solenoid valve (A7/3y15) (-)	29	not used
2	ASR/ETS hydraulic unit, left rear axle solenoid valve (release) (A7/3y11) (-)	18	ASR/ETS hydraulic unit, left front axle solenoid valve (hold) (A7/3y6) (-)	30	Left front axle VSS sensor (L6/1) (+)
3	ASR/ETS hydraulic unit, right rear axle solenoid valve (hold) (A7/3y12) (-)	19	ASR/ETS hydraulic unit, switchover/solenoid valve (A7/3y5) (-)	31-33	not used
4	Master brake cylinder switchover valve (Y61)	20	ASR/ETS hydraulic unit, left front axle solenoid valve (release) (A7/3y7) (-)	34	Right front axle VSS sensor (L6/2) (+)
5-6	not used	21	Model 140: SPS P-valve (Y10) (-)	35	not used
7	ASR/ETS hydraulic unit, high-pressure/return pump relay (A7/3k2) and solenoid valve relay (A7/3k1)	22	Model 140: SPS P-valve (Y10) (+)	36	ASR/ETS hydraulic unit, high-pressure/return pump relay (A7/3k2) control
8-9	not used	23	ASR/ETS hydraulic unit, right rear axle solenoid valve (hold) (A7/3y12) (-)	37	not used
10	Left front axle VSS sensor (L6/1) (-)	24	ASR/ETS hydraulic unit, right rear axle solenoid valve (hold) (A7/3y13) (-)	38	ASR/ETS hydraulic unit, right front axle solenoid valve (hold) (A7/3y8) (-)
11-12	not used	25-26	not used	39	ASR/ETS hydraulic unit, right front axle solenoid valve (release) (A7/3y9) (-)
13	Right front axle VSS sensor (L6/2) (-)	27	ASR/ETS hydraulic unit, solenoid valve relay (A7/3k1) (-)	40-41	not used
14-16	not used	28	ASR/ETS hydraulic unit, high-pressure/return pump relay (A7/3k2) (-)		