

Electrical Test Program - Preparation for Test

Preliminary work:

Diagnosis - Diagnostic Trouble Code (DTC) Memory 11

1. Review section 11, 12, 21, 22, 23, 31,
2. Ignition: **OFF**
3. Fuse on relay module (K40) in order.
Relay module in order.
Relay module plugs connected.
4. Disconnect engine control module (IFI) (N3/7) connector.
5. Connect socket box with test cable to engine control module (IFI) (N3/7).

Electrical wiring diagrams:

Electrical Troubleshooting Manual, Model 210, Volume 1

Special Tools

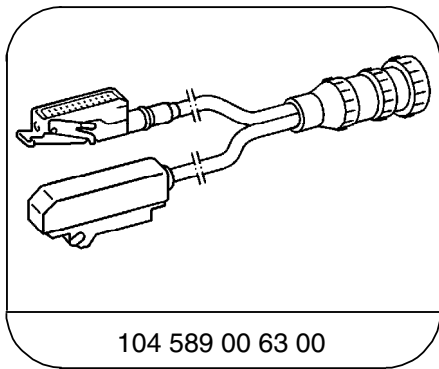

104 589 00 63 00

Test cable

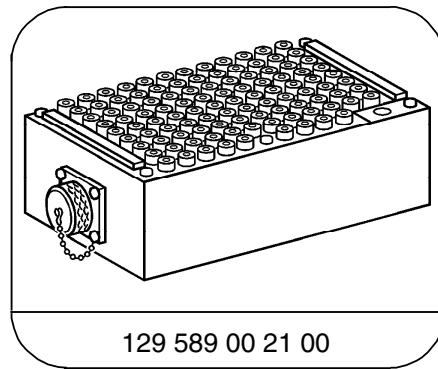

129 589 00 21 00

126-pin socket box

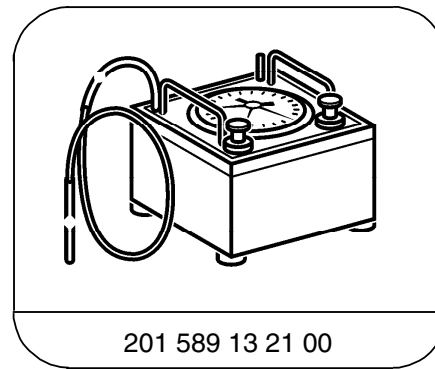

201 589 13 21 00

Tester

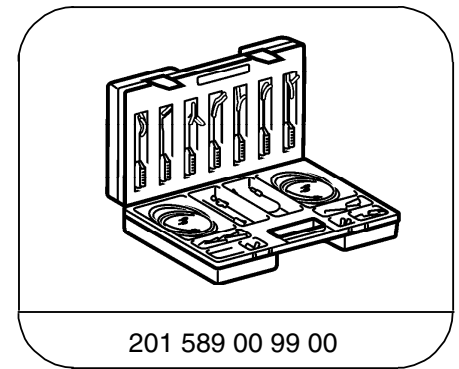

201 589 00 99 00

Electrical connecting set

Electrical Test Program - Preparation for Test

Test equipment; See MBUSA Standard Service Equipment Program

Description	Brand, model, etc.
Digital multimeter	Fluke models 23, 77 III, 83, 85, 87
Y - fitting	117 078 01 45

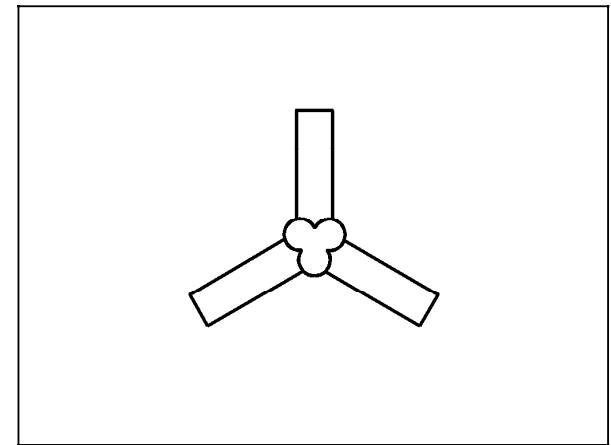

P07.12-0438-01

Figure 1
Y - fitting

Electrical Test Program – Preparation for Test

Connection Diagram – Socket box

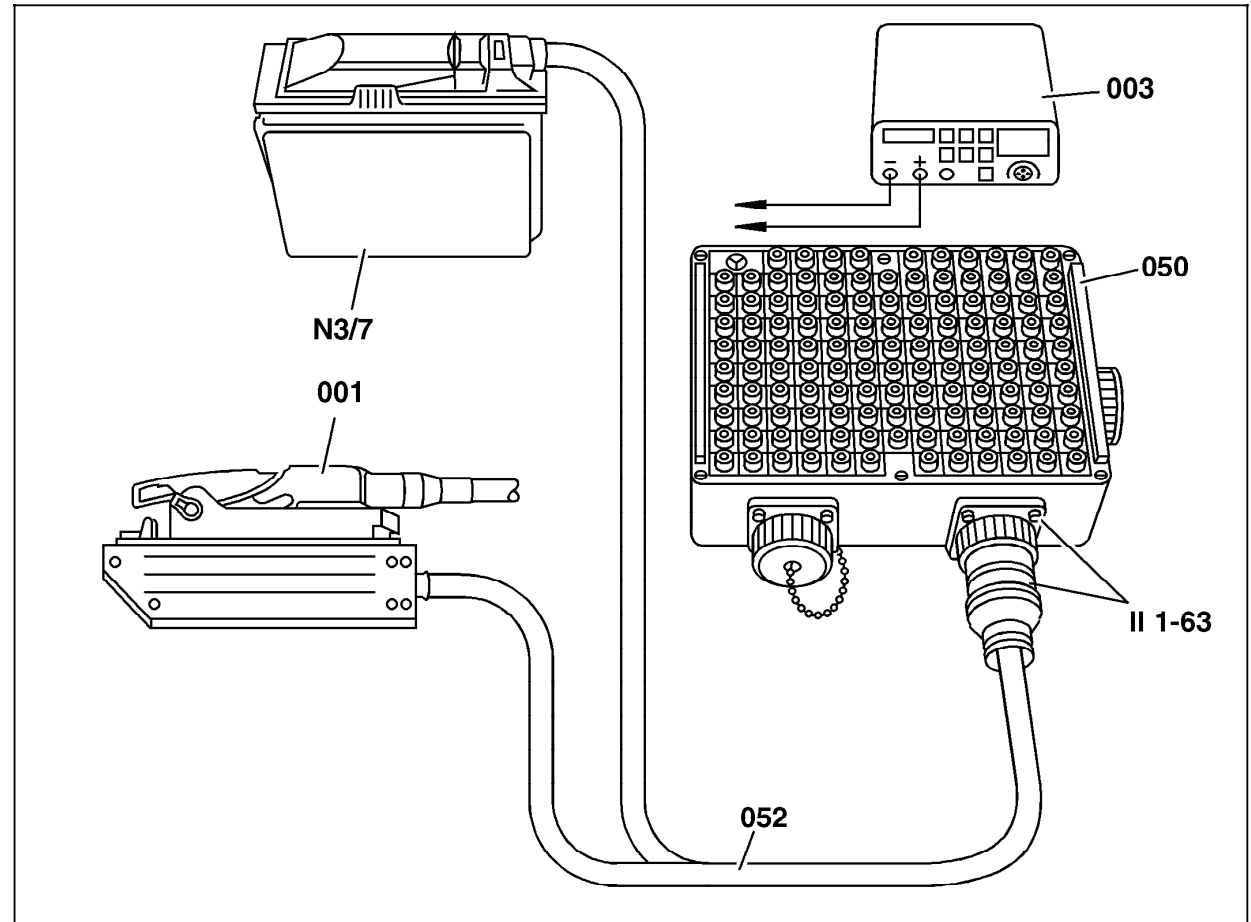

Figure 2

- 001 Engine control module (IF) (N3/7) connector
- 003 Multimeter
- 050 Socket box (126-pole)
- 052 Test cable

- N3/7 Engine control module (IF) (N3/7)
- II 1-63 Socket and plug of test cable

P07.12-0439-06

Electrical Test Program – Preparation for Test

Connector Layout - Engine Control Module (IFI) (N3/7)

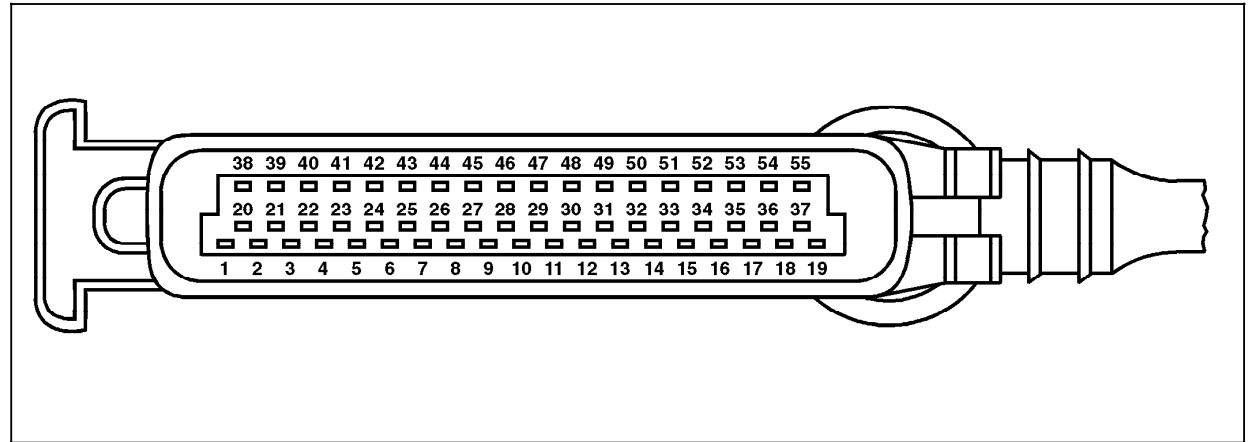

P07.12-0440-04

Figure 3

1	–	16	–
2	–	17	–
3	Fuel temperature sensor in electrohydraulic shut-off actuator, socket 4	18	Ground W16/5 – W16/6 (electronics)
4	Sensor ground GND	19	Ground W16/5 – W16/6 (electronics)
5	CAN data bus (socket L)	20	CKP sensor (socket 1)
6	IFI/DFI accelerator pedal position sensor (potentiometer, socket 6)	21	EGR lifting sender (B28/3) (socket 3)
7	Oil level switch (S43)	22	Pressure sensor (socket 1)
8	CC switch (accelerate/set, socket 4)	23	ECT sensor (socket 2)
9	Fuel rack position sensor (socket 7)	24	IFI/DFI accelerator pedal position sensor (CTP switch, socket 3)
10	Fuel rack position sensor (socket 1)	25	–
11	Resonance intake manifold switchover valve	26	Terminal HRL from relay module K40 (connector E, socket 3)
12	Resonance intake line switch	27	P/N signal from transmission control module (N15/3)
13	Circuit 50 (glow/starter switch)	28	Sensor ground (B28/3, L5/6)
14	TN-signal (data link connector, pin 13)	29	IFI/DFI accelerator pedal position sensor (potentiometer socket 1)
15	IFI/DFI accelerator pedal position sensor (CTP switch, socket 4)	30	CC switch (control contact, socket 6)

Electrical Test Program – Preparation for Test

Connector Layout - Engine Control Module (IFI) (N3/7)

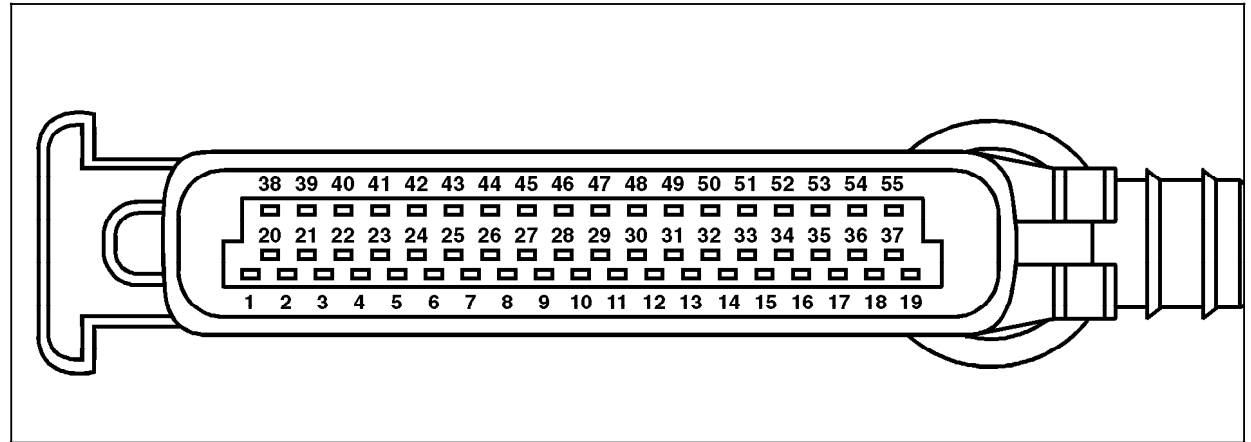

P07.12-0440-04

Figure 4

31	–	47	Circuit 15E
32	Resonance intake manifold switch	48	–
33	Preglow control module (N14/2)	49	–
34	–	50	Diagnostic signal (to X11/4, socket 4)
35	EGR valve vacuum transducer (Y31/1)	51	Resonance intake line switchover valve (socket 1)
36	Fuel quantity actuator (socket 2)	52	–
37	Voltage supply, circuit 87U, unfused (relay module K40, connector E, socket 7)	53	Pressure control flap vacuum transducer (socket 1)
38	CC switch (decelerate/set, socket 3)	54	Fuel quantity actuator (socket 2)
39	IFI accelerator pedal position sensor (potentiometer, socket 5)	55	Voltage supply, circuit 87U, unfused (relay module K40, connector E, socket 7)
40	IAT sensor (socket 2)		
41	CAN data bus (socket H)		
42	CC switch (resume, socket 5)		
43	IFI electrohydraulic shut-off actuator (socket 3)		
44	CC switch (off, socket 1)		
45	Pressure sensor (socket 3)		
46	Fuel rack position sensor (socket 6)		