

Hydraulic Test Program - Preparation for Test (Fuel Pump Test)

Connection Diagram - Delivery Test

- Connect socket box to engine control module (N3/4).

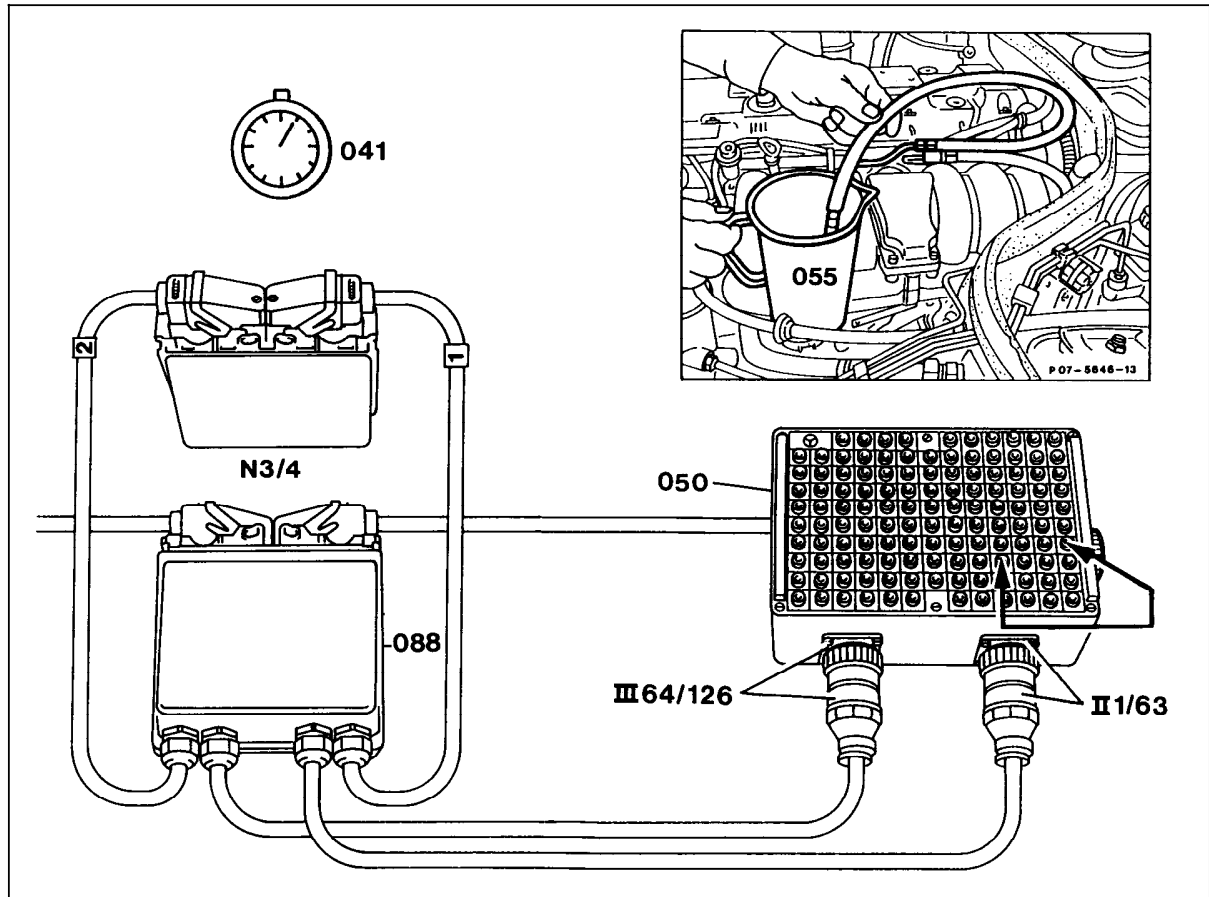

Figure 1

- 003 Multimeter
- 041 Stop watch
- 050 Socket box (126-pole)
- 055 Measuring glass
- 088 Test cable

P07-5707-57

Hydraulic Test Program - Preparation for Test (Fuel Pump Test)

Connection Diagram - Fuel Pump Pressure Test

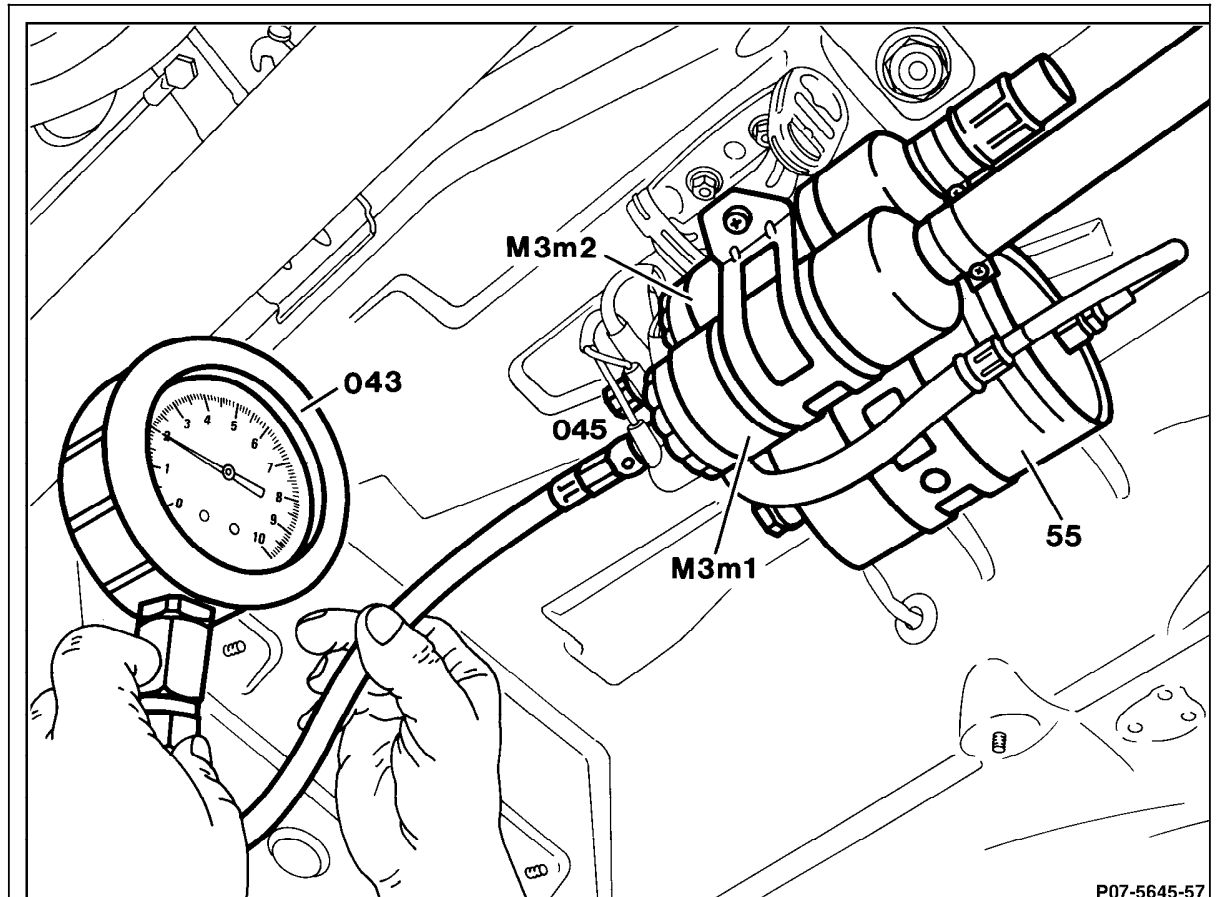

Figure 2

- 043 Pressure gauge, part no. 103 589 00 21 00
- 045 Adaptor, part no. 103 589 02 63 00
- 55 Fuel filter
- M3m1 Fuel pump 1
- M3m2 Fuel pump 2

P07-5645-57
P07-5645-57

Hydraulic Test Program - Preparation for Test (Fuel Pump Test)

Special Tools

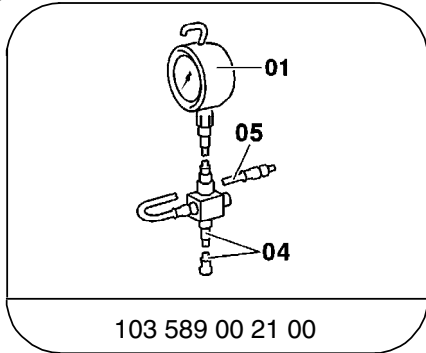

103 589 00 21 00

Tester

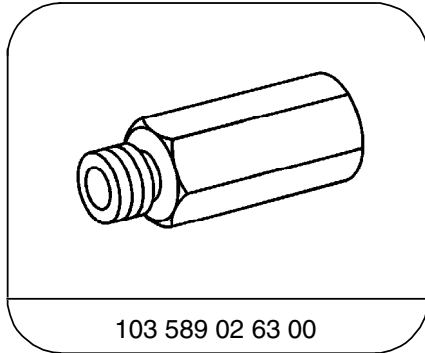

103 589 02 63 00

Adapter

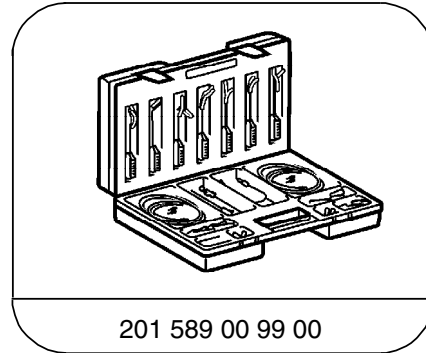

201 589 00 99 00

Electrical connecting set

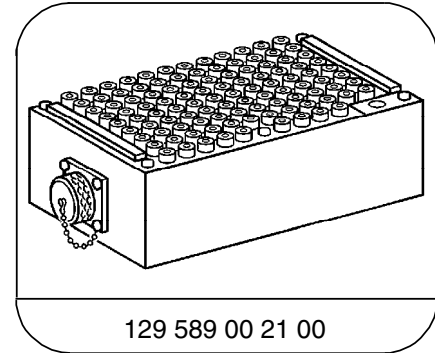

129 589 00 21 00

126-pin socket box

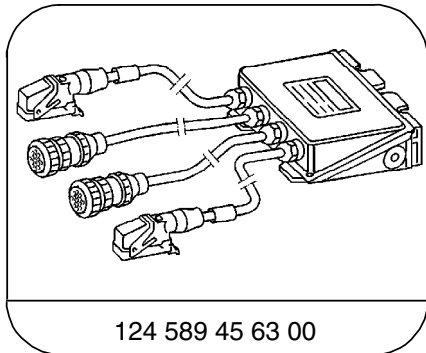

124 589 45 63 00

82-pin test cable CAN

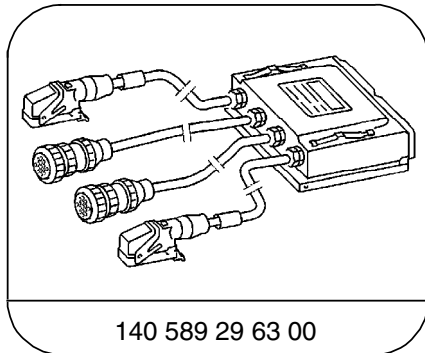

140 589 29 63 00

CAN 140 82-pin test cable

Equipment

Fuel hose (500 mm, 20 in)	local purchase
Measuring glass (1 liter minimum)	local purchase
Stop watch	local purchase
Multimeter ¹⁾	Fluke models 23, 83, 85, 87

¹⁾ Available through the MBUSA Standard Equipment Program.