

Electrical Test Program – Preparation for Test

Preliminary work:

Diagnosis - Diagnostic Trouble Code (DTC) Memory 11

Preparation for Test

1. Ignition: **OFF**
2. Remove LH-SFI control module (N3/1).
3. Connect socket box with contact module 140 589 02 63 00 and contact box to LH-SFI control module (N3/1) according to connection diagram.
4. **Test steps 1.2, 1.3, 2.2 – 2.5, 4 and 36 only!**

Ignition: **OFF**

Remove base module (N16/1) and connect socket box with contact module 140 589 01 63 00 and contact box to base module (see DM, Chassis and Drivetrain, Volume 1, section 1, 22).



- When performing test and adjustment work, the engine rpm should only be raised using the accelerator pedal. If the engine speed is raised via the control linkage in the engine compartment, the “limp-home” mode will be activated and will be registered as a DTC in the EA/CC/ISC control module. The ASR MIL will also come on.
- If installing a LH-SFI control module from another vehicle, the control module’s self-adaptation feature must be reset to its mean value (see 11).

Wiring diagrams:

Electrical Troubleshooting Manual, Models 124, 129, 140

Note regarding “Test Connection” column:

The numbers indicated in parentheses, for example, ⇒ 1.0 (1.23) signify:

- 1= Connector 1 on wiring diagram,
- 23= Socket 23 on wiring diagram.

Electrical Test Program – Preparation for Test

Special Tools

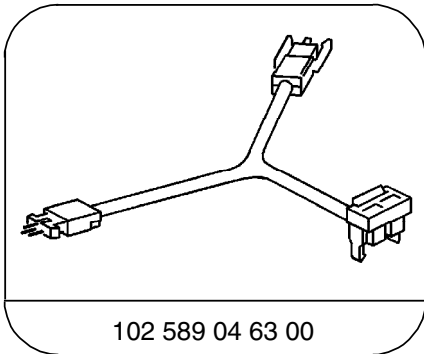

102 589 04 63 00

Test cable

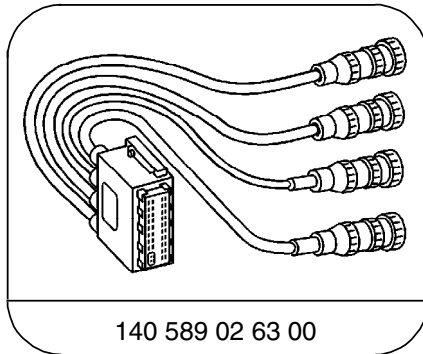

140 589 02 63 00

Contacting module 2

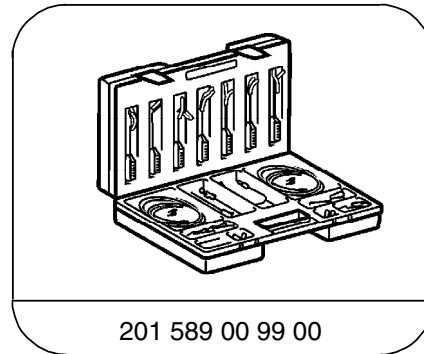

201 589 00 99 00

Electrical connecting set

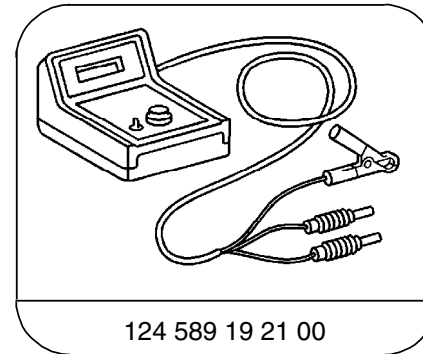

124 589 19 21 00

Pulse counter

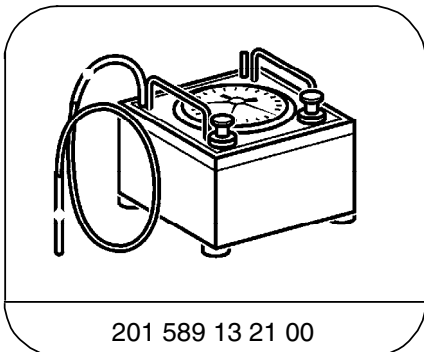

201 589 13 21 00

Tester

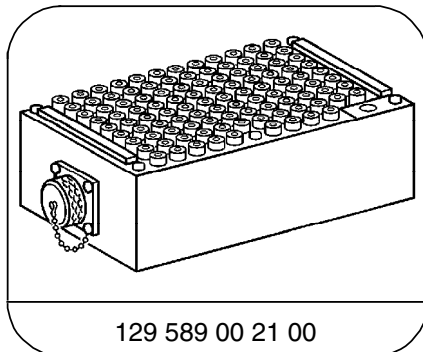

129 589 00 21 00

126-pin socket box

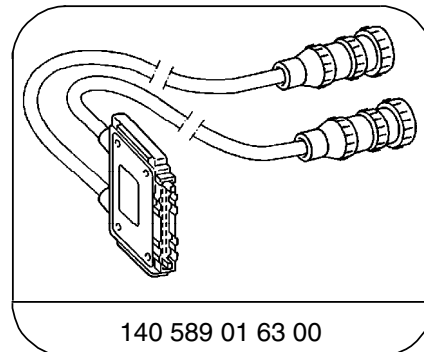

140 589 01 63 00

Contacting module 1

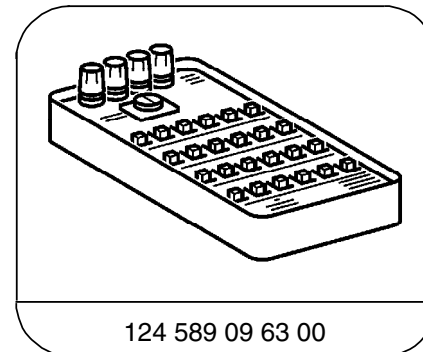

124 589 09 63 00

Ohm decade

Electrical Test Program – Preparation for Test

Special Tools

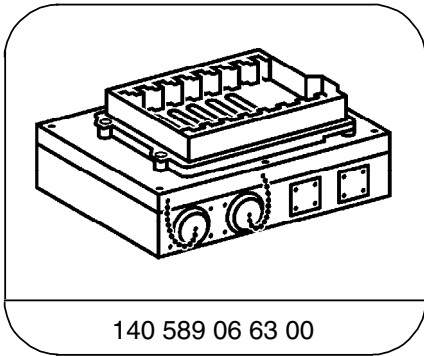

140 589 06 63 00

Contacting box

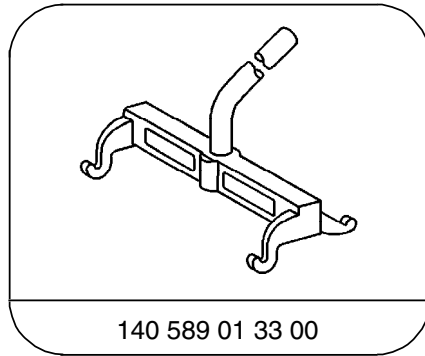

140 589 01 33 00

Mounting lever

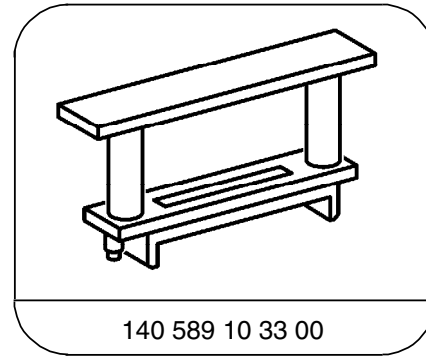

140 589 10 33 00

Spacer

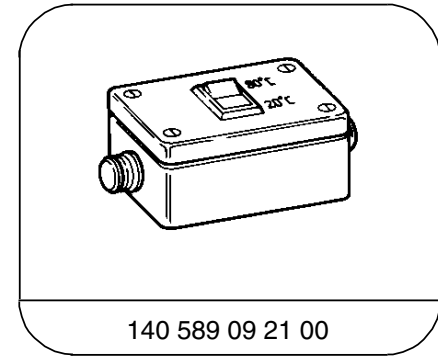

140 589 09 21 00

Simulator

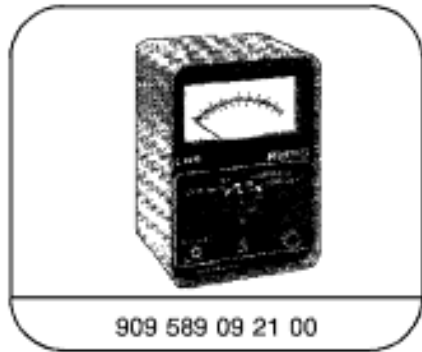

909 589 09 21 00

On-Off Ratio Tester

Conventional tools, test equipment

Description	Brand, model, etc.
Multimeter ¹⁾	Fluke models 23, 83, 85, 87
Engine analyzer ¹⁾	Bear DACE (Model 40-960) Sun MEA-1500MB

¹⁾ Available through the MBUSA Standard Equipment Program.

Electrical Test Program – Preparation for Test

Connection Diagram - Socket Box
Models 124 and 129

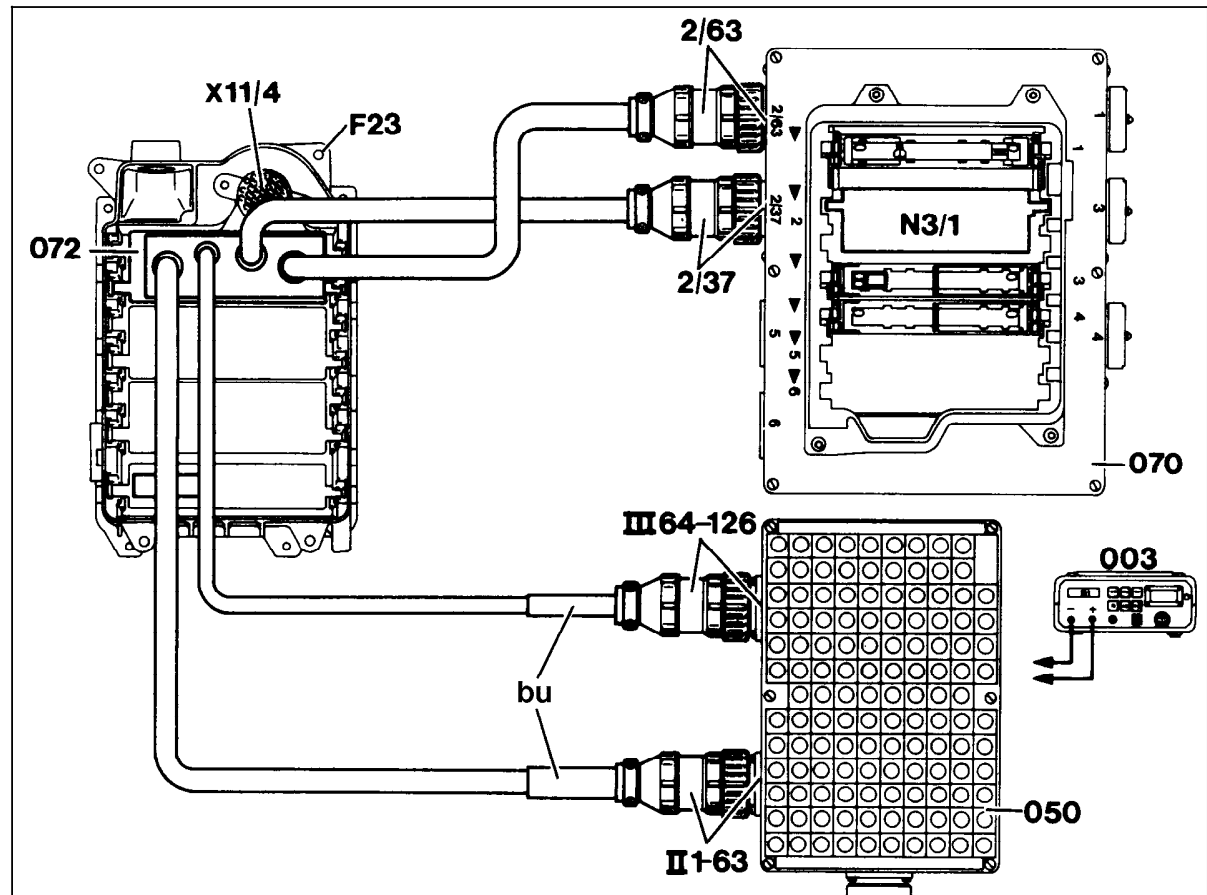

U07-0727-57

Figure 1

- 003 Multimeter
- 050 Socket box (126-pole)
- 070 Contact box
- 072 Contact module
- F23 Module box
- N3/1 LH-SFI control module
- X11/4 Data link connector (DTC readout)
- bu blue

Electrical Test Program – Preparation for Test

Connection Diagram - Socket Box
Model 140

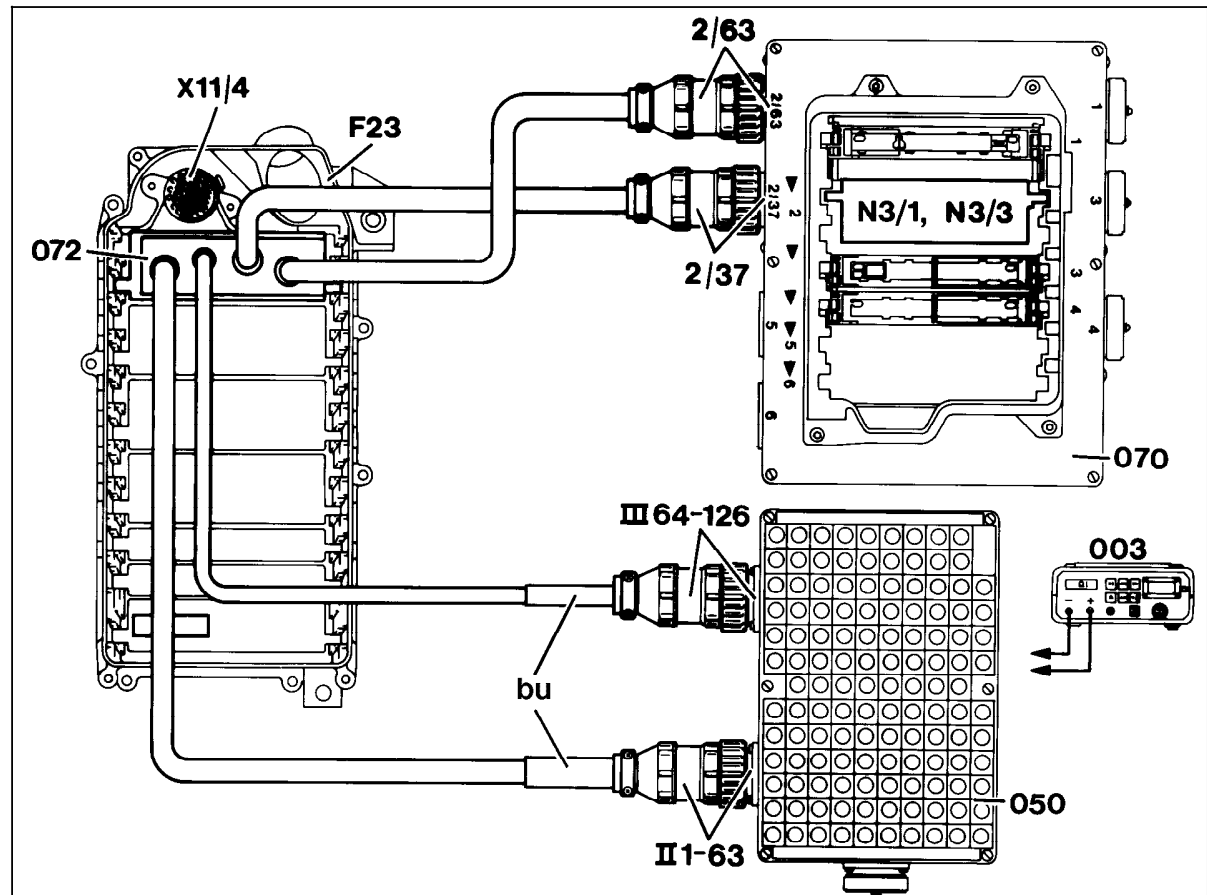

U07-0728-57

Figure 2

- 003 Multimeter
- 050 Socket box (126-pole)
- 070 Contact box
- 072 Contact module
- F23 Module box
- N3/1 LH-SFI control module
- X11/4 Data link connector (DTC readout)
- bu blue

Electrical Test Program – Preparation for Test

Layout LH-SFI Control Module Connector “1” – Interior

Figure 3

- | | |
|---------|--|
| 1 – 8 | Not used |
| 9 | Fuel consumption gauge |
| 10 | Not used |
| 11 | CTP (idle) recognition from EA/CC/ISC control module or CC/ISC control module |
| 12 | Not used |
| 13 | Diagnostic wire |
| 14 | Diagnostic wire insulation |
| 15 – 22 | Not used |
| 23 | Ground (model 124: component compartment - W16, model 129: module box bracket - W27, model 140: electronics output ground - W15) |
| 24 | Voltage supply, circuit 87 |
| 25 | FP relay module |
| 26 | Voltage supply, circuit 30 |
| 27 | Not used |
| 28 | TN-signal (rpm signal) output |
| 29 | Not used |
| 30 | Fuel safety sut-off from EA/CC/ISC or CC/ISC control module |
| 31 - 33 | Not used |
| 34 | Starter signal, circuit 50 |
| 35 | Ground (model 124: module box bracket - W27, model 129, 140: electronics, right footwell - W15/1) |
| 36 | Voltage supply, circuit 87 |
| 37 | Ground (model 124: component compartment - W16, model 129: module box bracket - W27, model 140: electronics output ground - W15) |
| 38 | Not used |
| L | CAN (-)
Controller area network (LH-SFI, DI, ABS/ASR, EA/CC/ISC, CC/ISC control modules) |
| H | CAN (+)
Controller area network (LH-SFI, DI, ABS/ASR, EA/CC/ISC, CC/ISC control modules) |

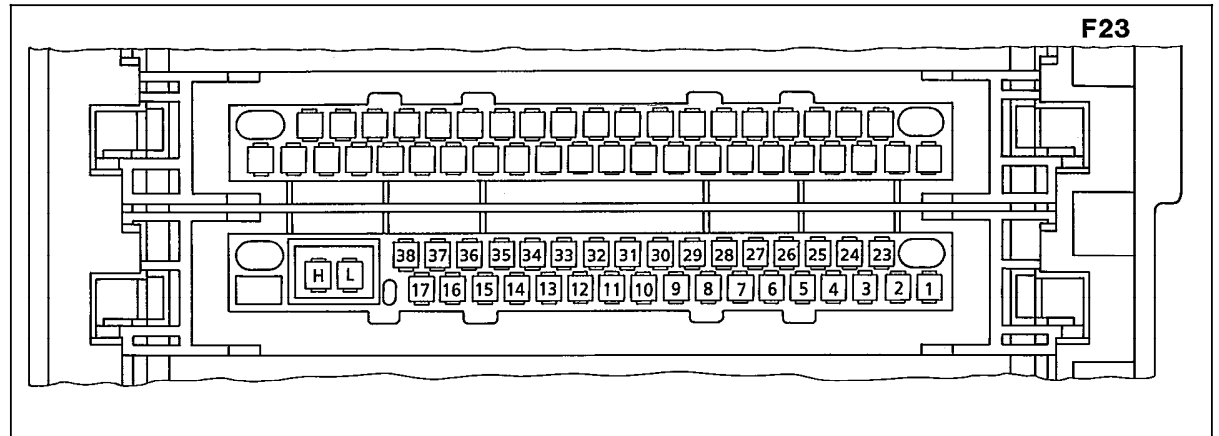

P07-5171-53

Electrical Test Program – Preparation for Test

Layout LH-SFI Control Module Connector “2” – Engine Compartment

Figure 4

- 1 Injector (2) (engine 119 only)
- 2 Injector (engine 104 [4], engine 119 [3])
- 3 Injector (engine 104 [6], engine 119 [8])
- 4 Injector (5)
- 5 TN-signal (rpm signal) (input)
- 6 CMP sensor signal
- 7 Not used
- 8 IAT sensor
- 9 O2S 1 heater
- 10 – 12 Not used
- 13 O2S 1 wire insulation
- 14 O2S 1 (before TWC)
- 15 O2S 1 ground
- 16 Sensor ground
- 17 Hot wire MAF sensor signal
- 18 ECT sensor, circuit 2
- 19 AIR relay module
- 20 Upshift delay control
- 21 Not used
- 22 Right adjustable camshaft timing solenoid (engine 119 only)

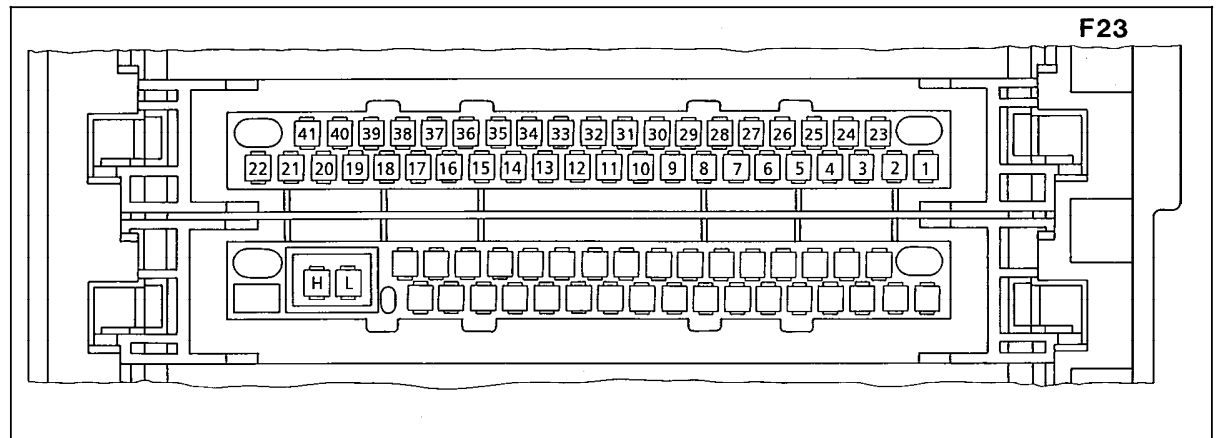

P07-5170-53

Electrical Test Program – Preparation for Test

Layout LH-SFI Control Module Connector “2” – Engine Compartment (continued)

Figure 5

- 23 Hot wire MAF sensor voltage supply
- 24 Injector (7) (engine 119 only)
- 25 Injector (engine 104 [2], engine 119 [6])
- 26 Injector (engine 104 [3], engine 119 [4])
- 27 Injector (1)
- 28 – 29 Not used
- 30 Coding (ground)
- 31 ECT sensor, circuit 1
- 32 – 33 Not used
- 34 Hot wire MAF sensor ground
- 35 Not used
- 36 On-off ratio measurement output
- 37 Burn-off signal for hot wire MAF sensor
- 38 Purge control valve
- 39 EGR switchover valve
- 40 1 GR start relay module (K29/1)
Model 124.034 only
- 41 Left adjustable camshaft timing solenoid

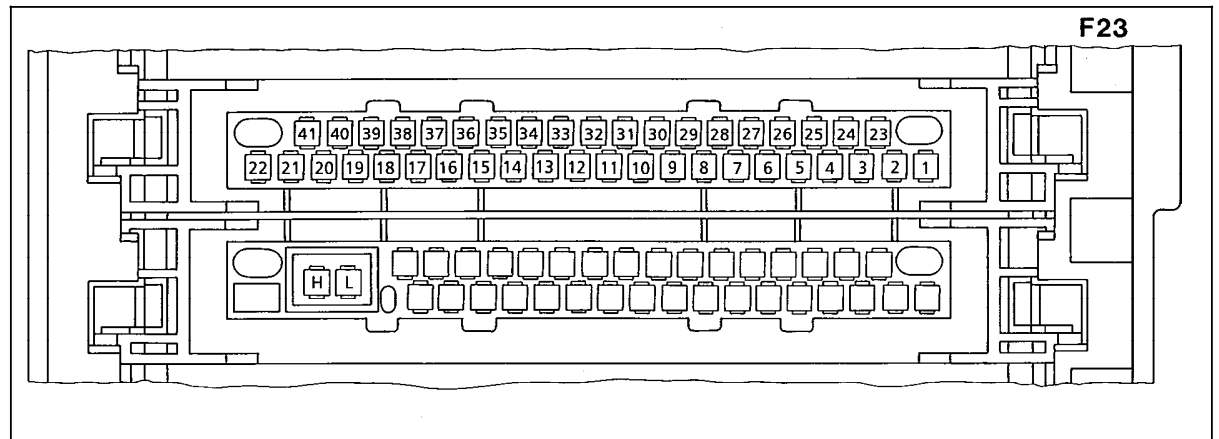

P07-5170-53