

Hydraulic Test Program - Preparation for Test (Cold Start Test)

- Connect pressure gauge on test connection (31/1).
- After completing test, using measurement glass (055), release fuel pressure and allow residual fuel to drain into glass (31/1).

Special Tools

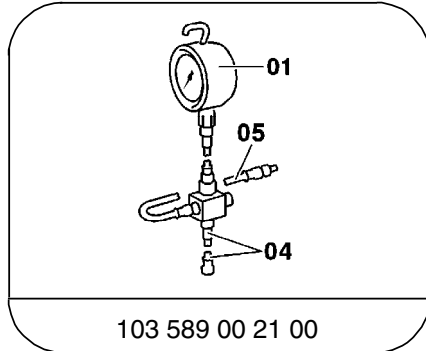

103 589 00 21 00

Tester

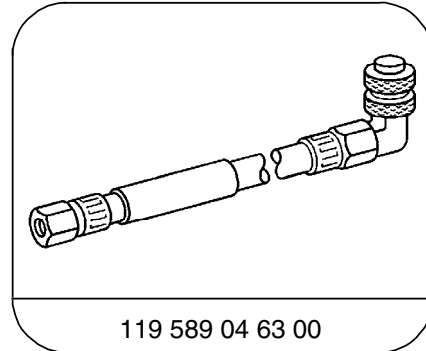

119 589 04 63 00

Pressure hose

Equipment

Engine analyzer ¹⁾	Bear DACE (Model 40-960) Sun MEA-1500MB
-------------------------------	--

¹⁾ Available through the MBUSA Standard Equipment Program.