

## 5.2 Distributor Ignition (DI)

Engines 104, 119 LH-SFI

### Electrical Test Program – Component Locations

#### Engine Compartment Model 140 with Engine 104

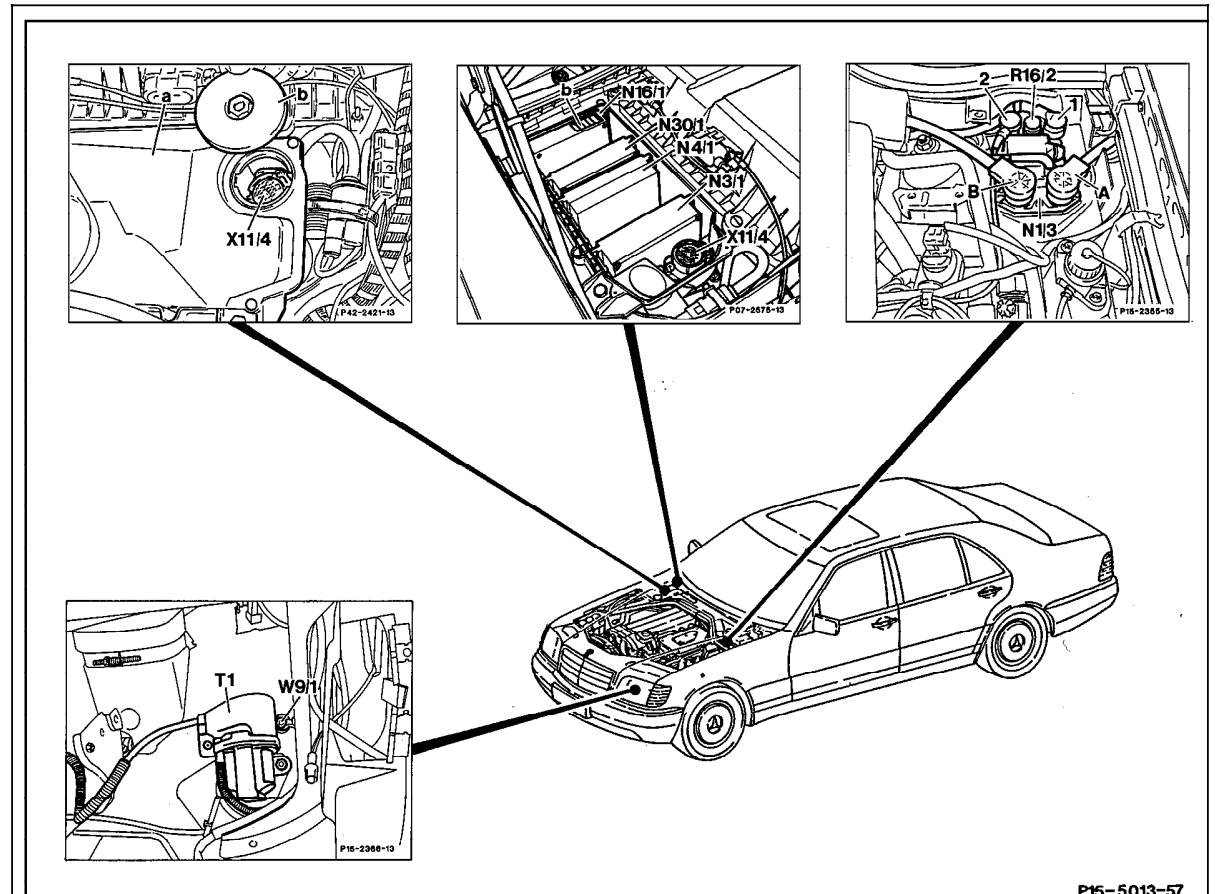

P15-5013-57

P15-5013-57

## 5.2 Distributor Ignition (DI)

## Engines 104, 119 LH-SFI

### Electrical Test Program – Component Locations

#### Engine 104

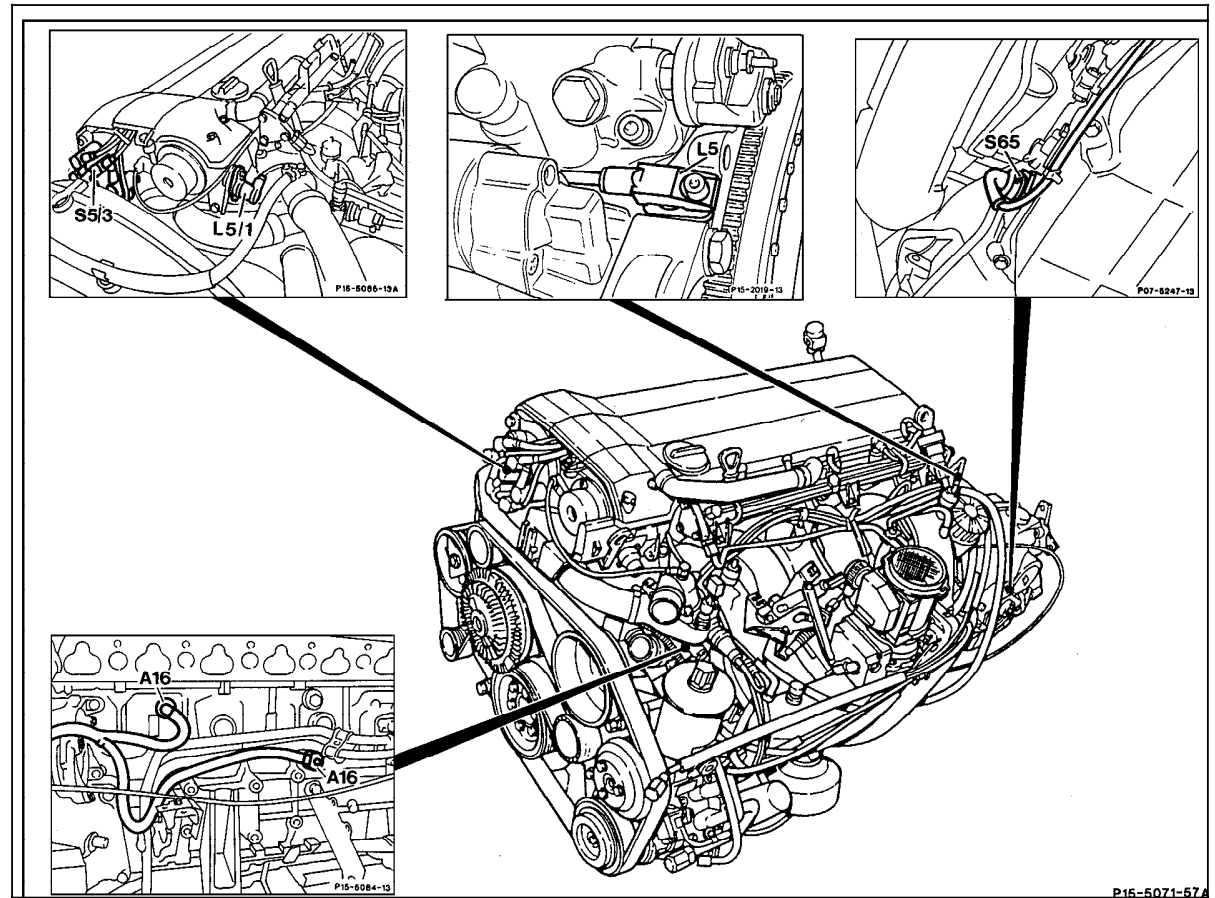

Figure 2

- A16 Knock sensors
- L5 CKP sensor
- L5/1 CMP sensor
- S5/3 High-voltage distributor
- S65 Transmission overload protection switch

P15-5071-57A  
P15-5071-57A

### Electrical Test Program – Component Locations

#### Engine Compartment Model 124 with Engine 119

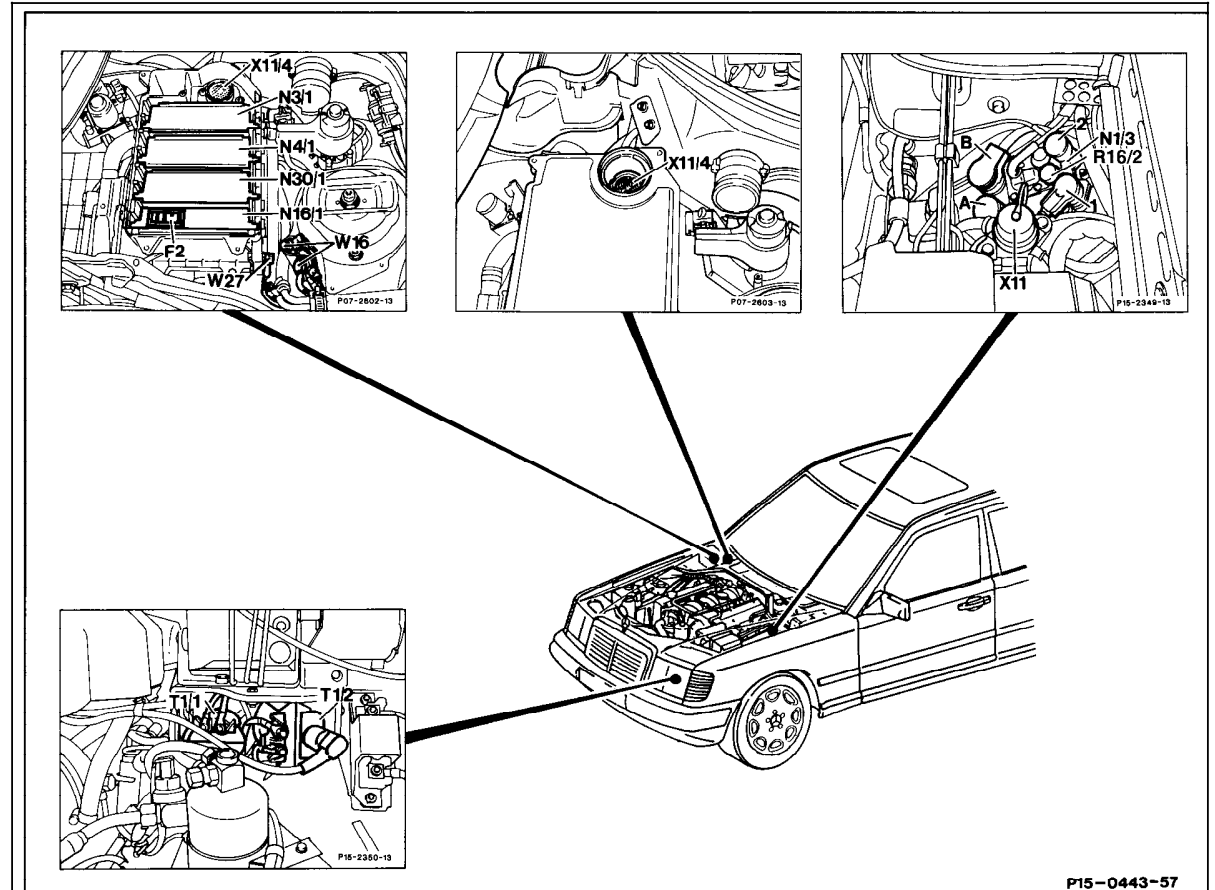

Figure 3

- N1/3 DI control module
- N3/1 LH-SFI control module
- N4/1 EA/CC/ISC control module
- N16/1 Base module
- N30/1 ASR control module
- R16/2 Reference resistor (DI)
- T1/1 Ignition coil 1 (right cylinder bank)
- T1/2 Ignition coil 2 (left cylinder bank)
- X11/4 Data link connector (DTC readout)

P15-0443-57

P15-0443-57

### Electrical Test Program – Component Locations

#### Engine Compartment Model 140 with Engine 119

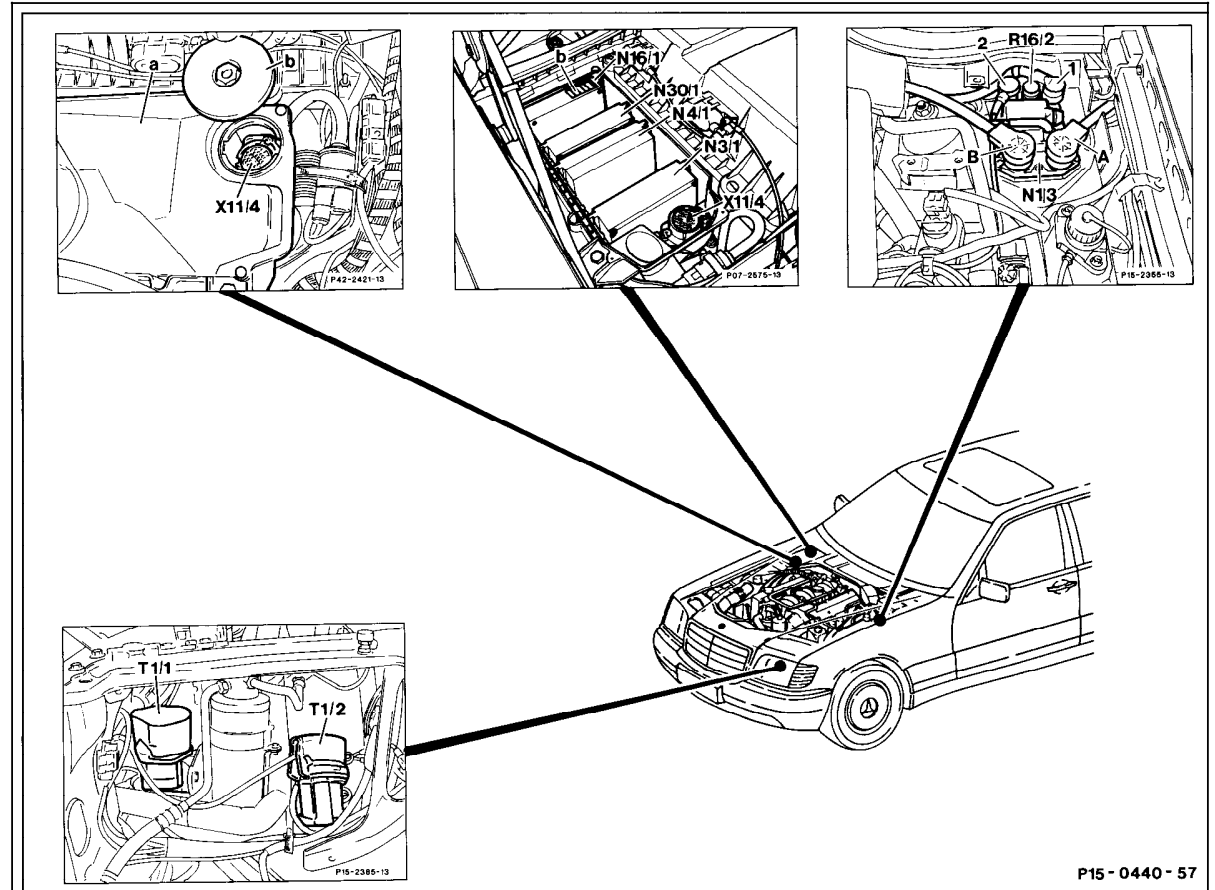

Figure 4

- N1/3 DI control module
- N3/1 LH-SFI control module
- N4/1 EA/CC/ISC control module
- N16/1 Base module
- N30/1 ASR control module
- R16/2 Reference resistor (DI)
- T1/1 Ignition coil 1 (right cylinder bank)
- T1/2 Ignition coil 2 (left cylinder bank)
- X11/4 Data link connector (DTC readout)

P15-0440-57

P15-0440-57

### Electrical Test Program – Component Locations

#### Engine 119

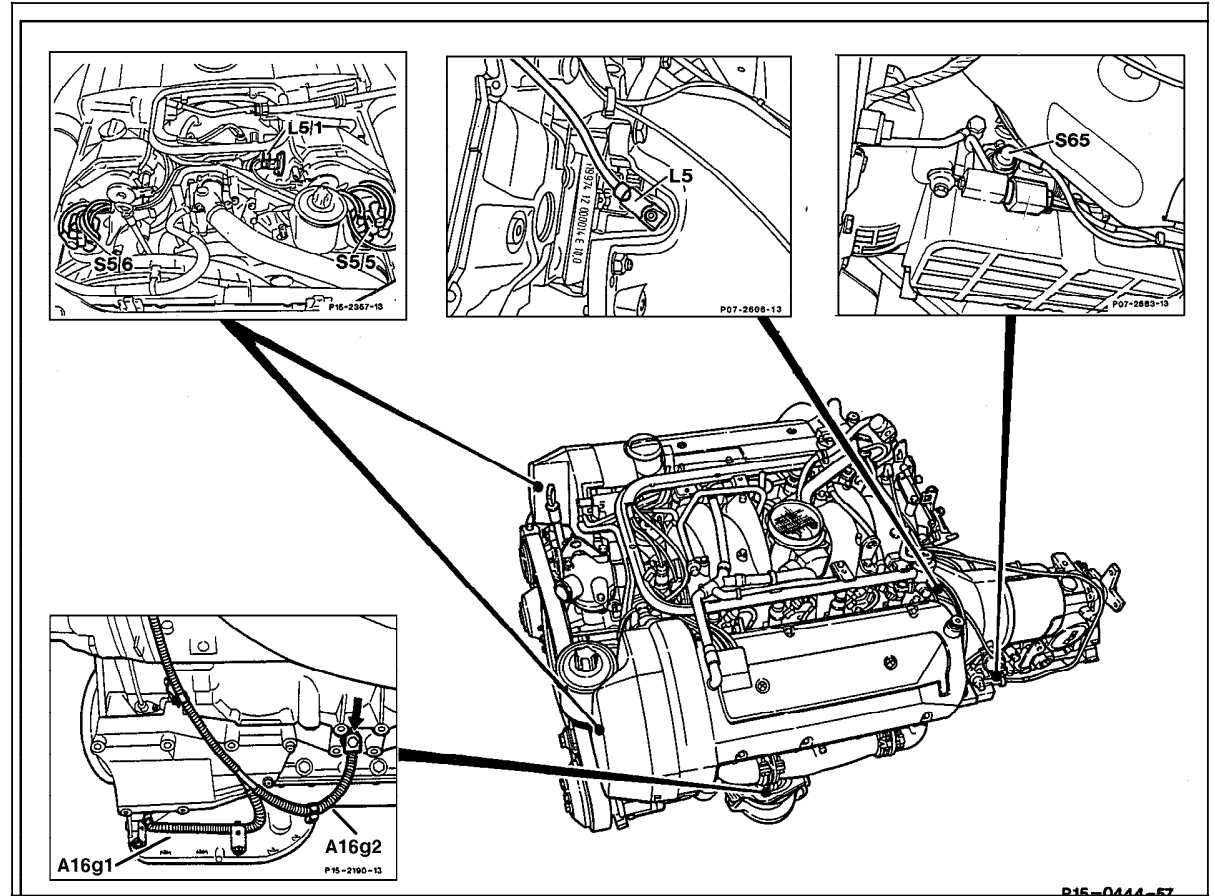

Figure 5

- A16 Knock sensors
- A16g1 KS 1 (right side of engine)
- A16g2 KS 2 (left side of engine)
- L5 CKP sensor
- L5/1 CMP sensor
- S5/5 Left high-voltage distributor
- S5/6 Right high-voltage distributor
- S65 Transmission overload protection switch

P15-0444-57  
P15-0444-57