

Electrical Test Program - Preparation for Test

Preliminary work: Diagnosis – Diagnostic Trouble Code (DTC) Readout 11

1. Ignition: **OFF**
2. Remove EA/CC/ISC module (N4/1).
3. Connect socket box (see connection diagram).

Electrical wiring diagrams :
 Electrical Troubleshooting Manual, Model 129
 Electrical Troubleshooting Manual, Model 140

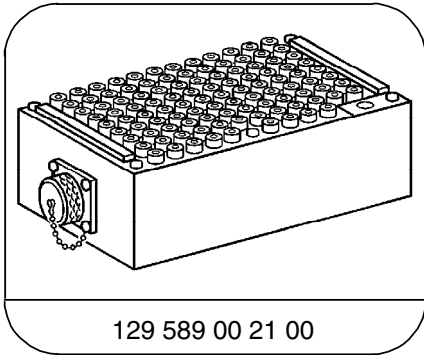

129 589 00 21 00

126-pin socket box

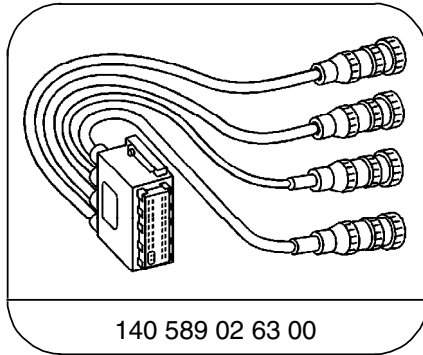

140 589 02 63 00

Contacting module 2

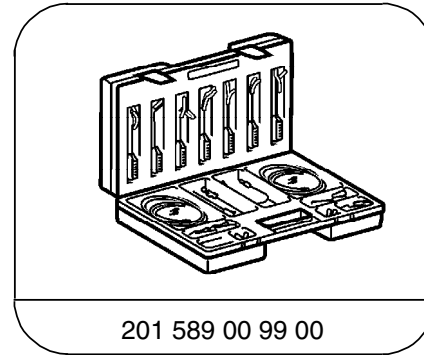

201 589 00 99 00

Electrical connecting set

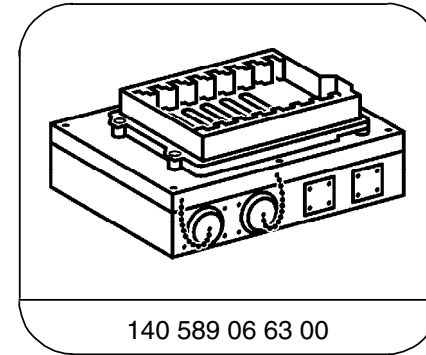

140 589 06 63 00

Contacting box

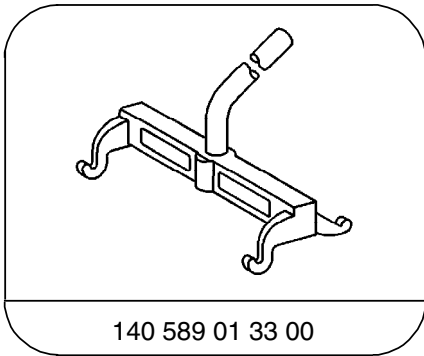

140 589 01 33 00

Mounting lever

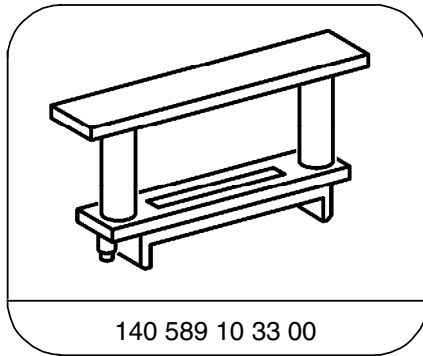

140 589 10 33 00

Spacer

Equipment

Digital multimeter ¹⁾

Fluke models 23, 83, 85, 87

¹⁾ Available through the MBUSA Standard Equipment Program. Two multimeters are required for the EA test program.

Electrical Test Program - Preparation for Test

Connection Diagram – Socket Box Model 129

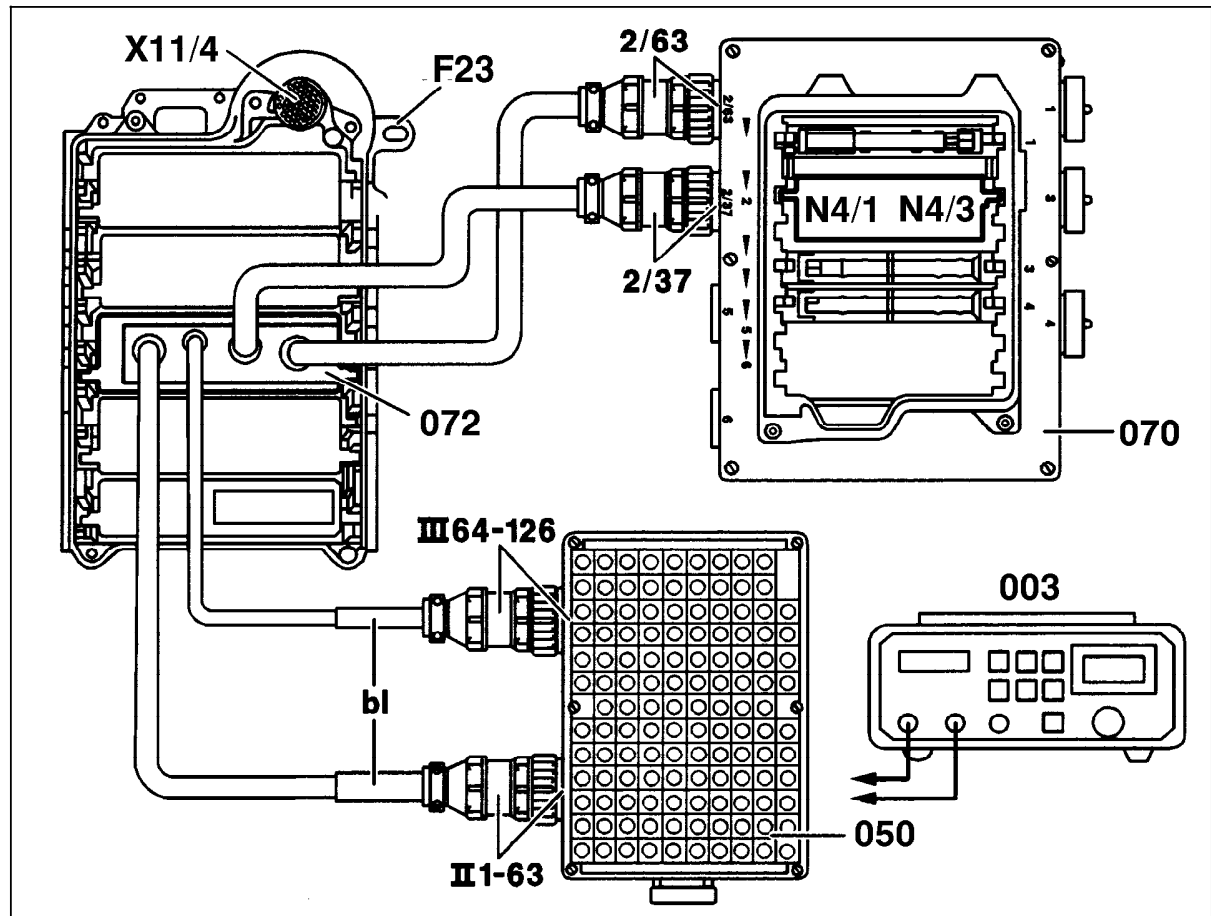

P30-5300-57

Figure 1

- F23 Module box
- N4/1 EA/CC/ISC module
- X11/4 Data link connector (DTC readout) (38-pole)
- 003 Digital multimeter
- 050 Socket box (126-pole)
- 070 Contact box
- 072 Contact module 2
- bl blue

Electrical Test Program - Preparation for Test

Connection Diagram – Socket Box Model 140

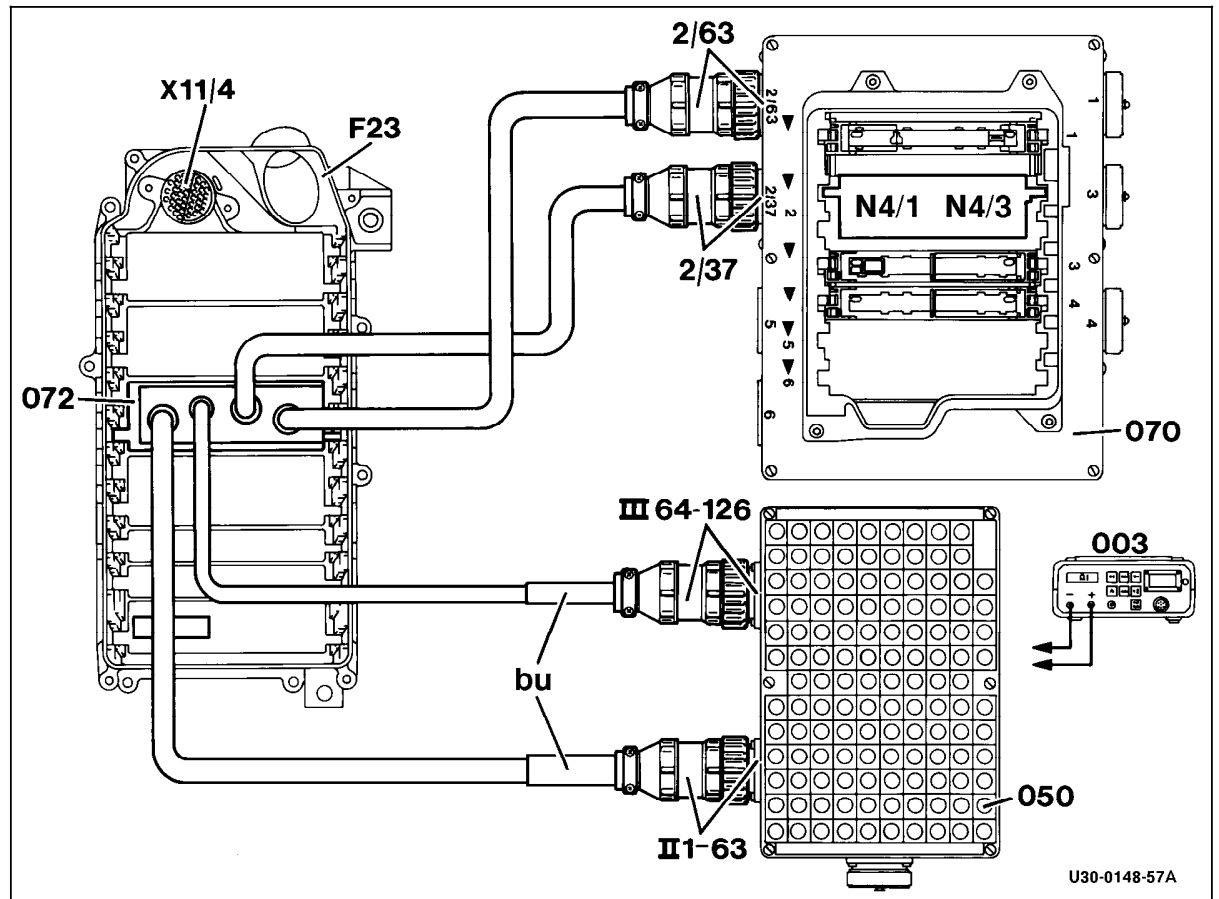

Figure 2

- F23 Module box
- N4/1 EA/CC/ISC module
- X11/4 Data link connector (DTC readout) (38-pole)
- 003 Digital multimeter
- 050 Socket box (126-pole)
- 070 Contact box
- 072 Contact module 2
- bu blue

Electrical Test Program - Preparation for Test

Layout of EA/CC/ISC Control Module Connector "1"

Figure 3

- | | |
|---------|---|
| 1 | Not used |
| 2 | Cruise control switch
(control switch contact) |
| 3 | Starter lock-out/backup lamp switch, transmission
range "D" recognition |
| 4 | Starter lock-out/backup lamp switch,
transmission range "D" recognition |
| 5 | Data link connector (DTC readout) (38-pole) |
| 6 | Not used |
| 7 | Fuel safety shut-off
(right LH-SFI control module (N3/3) signal) |
| 8 | Not used |
| 9 | Closed throttle position switch (ground) |
| 10 | Cruise control switch (SET, DECEL.) |
| 11 | Cruise control switch (SET, DECEL.) |
| 12 | Left rear wheel speed sensor, ABS/ASR control
module |
| 13 | Brake lamp switch (ground) |
| 14 | Not used |
| 15 | Left front wheel speed sensor, ABS/ASR control
module |
| 16 | A/C compressor input signal (base module) |
| 17 | Do not contact! |
| 18 – 22 | Not used |
| 23 | Closed throttle position recognition
(left LH-SFI control module (N3/2) |
| 24 | Closed throttle position recognition
(right LH-SFI control module (N3/3) |
| 25 | Closed throttle position contact switch, voltage
supply |
| 26 | Not used |
| 27 | Safety switch signal
(left LH-SFI control module, N3/2) |
| 28 – 29 | Not used |

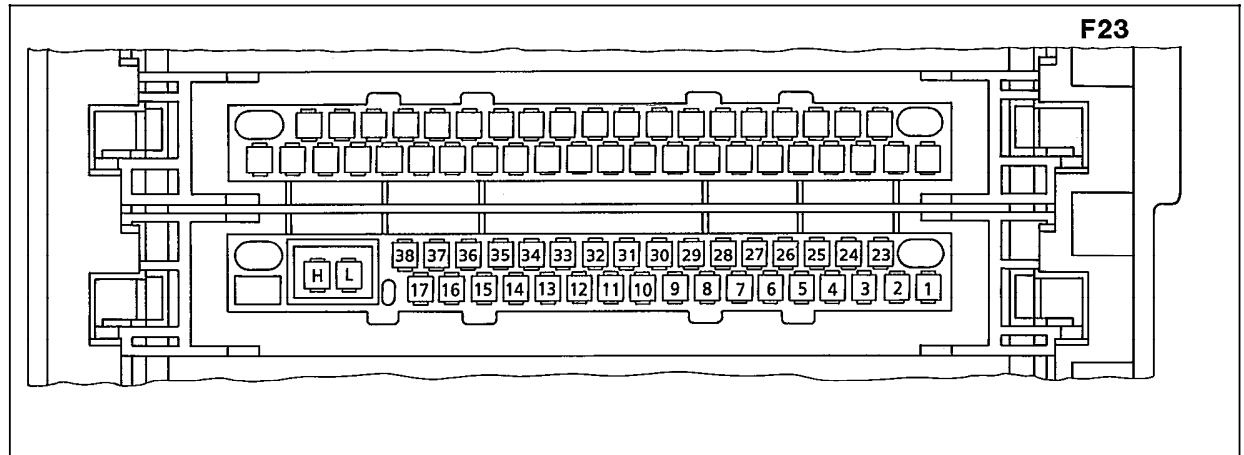

P07-5171-53

- | | |
|----|--|
| 30 | Brake lamp switch |
| 31 | Cruise control switch (SET, RESUME) |
| 32 | Idle speed increase diode matrix (V2), Model 140
only |
| 33 | Cruise control switch (OFF) |
| 34 | Engine speed signal (base module) |
| 35 | Voltage supply unfused circuit 87 Ug |
| 36 | Voltage supply unfused circuit 87 Ug |
| 37 | Ground W15, output ground (right footwell) |
| 38 | Ground W15, output ground (right footwell) |
| L | Data line (-)
Controller Area Network |
| H | Data line (+)
Controller Area Network |

Electrical Test Program - Preparation for Test

Layout of EA/CC/ISC Control Module Connector "2"

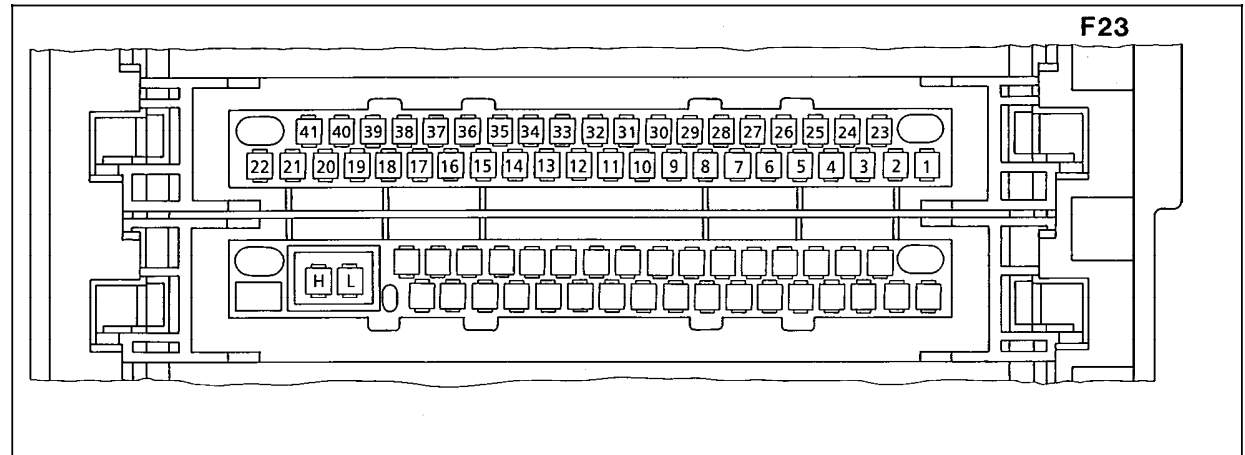

P07-5170-53

Figure 4

1	Left EA/CC/ISC actuator (motor ground)		
2	Left EA/CC/ISC actuator (motor ground)		
3	Left EA/CC/ISC actuator (motor voltage supply)		
4	Left EA/CC/ISC actuator(magnetic clutch ground)		
5 – 7	Not used		
8	Right EA/CC/ISC actuator (reference potentiometer signal)		
9	Right EA/CC/ISC actuator (actual value potentiometer signal)		
10	Right EA/CC/ISC actuator (reference and actual value potentiometer ground)		
11	Not used		
12	Right EA/CC/ISC actuator (reference and actual value potentiometer voltage supply)		
13 – 15	Not used		
16	Right EA/CC/ISC actuator (safety contact voltage supply)		
17 – 18	Not used		
19	Right EA/CC/ISC actuator (magnetic clutch ground)	30	Left EA/CC/ISC actuator (actual value potentiometer 3 signal)
20	Right EA/CC/ISC actuator (motor voltage supply)	31 – 32	Not used
21	Right EA/CC/ISC actuator (motor ground)	33	Left EA/CC/ISC actuator (actual value potentiometer 2 and 3 voltage supply)
22	Right EA/CC/ISC actuator (motor ground)	34	Not used
23	Right EA/CC/ISC actuator (motor voltage supply)	35	Left EA/CC/ISC actuator (safety contact signal)
24	Right EA/CC/ISC actuator (magnetic clutch voltage supply)	36 – 37	Not used
25 – 26	Not used	38	Left EA/CC/ISC actuator (closed throttle position signal)
27	Right EA/CC/ISC actuator (actual value potentiometer 2 signal)	39	Not used
28	Right EA/CC/ISC actuator (actual value potentiometer 2 and 3 ground)	40	Left EA/CC/ISC actuator (magnetic clutch voltage supply)
29	Not used	41	Left EA/CC/ISC actuator (motor voltage supply)