

Electrical Test Program - Preparation for Test

Preliminary work: Diagnosis – Diagnostic Trouble Code (DTC) Memory 11

1. Ignition: **OFF**
2. Remove diagnostic module (N59).
3. Connect socket box with test cable (according to connection diagram on next page).
4. **Test steps 1.2 – 1.3 and 2.1 – 2.2 only:** Ignition: **OFF**, remove base module (N16/1) and connect socket box with contact module 1 and contact box (see Diagnostic Manual, Chassis and Drivetrain, Volume 1, section 1 22).

Electrical wiring diagrams, see Electrical Troubleshooting Manual.

Special Tools

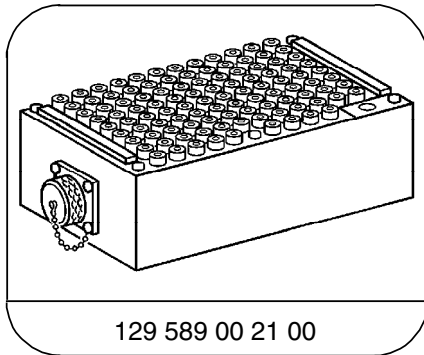

129 589 00 21 00

126-pin socket box

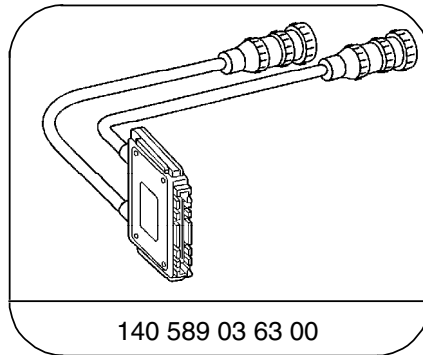

140 589 03 63 00

Contacting module 3

Equipment

Digital multimeter ¹⁾

Sun DMM-5
Fluke models 23, 83, 85, 87

¹⁾ Available through the MBUSA Standard Equipment Program.

Electrical Test Program - Preparation for Test

Connection Diagram – Socket Box Model 124

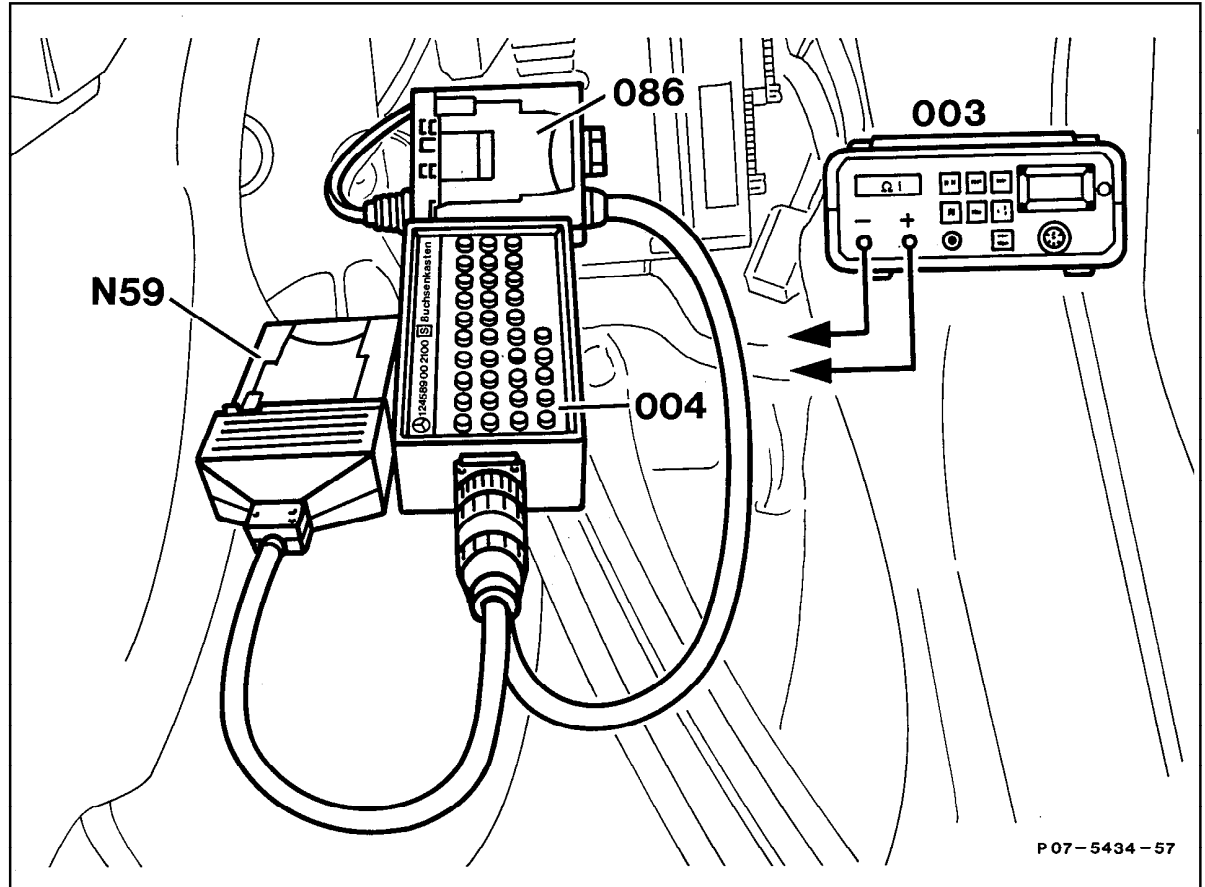

Figure 1

- 003 Multimeter
- 004 Socket box (35-pole)
- 086 Test cable
- N59 Diagnostic module

P 07-5434-57

P07-5434-57

Electrical Test Program - Preparation for Test

Terminal Layout of Diagnostic Module Model 124

Figure 2

- 1 Ground, module box bracket
- 2 Ground bridge, coding
- 3 Voltage supply, circuit 87
- 4 Voltage supply, circuit 30
- 5 Diagnostic wire at diagnostic connector X11/21
- 6 Diagnostic wire at diagnostic connector X11/4
- 7 Ground, coding (model 124.034)
- 8 Ground, coding (model 124.036)
- 9 "CHECK ENGINE" malfunction indicator lamp
- L Data line (-)
Controller Area Network
(LH-SFI control module, ignition control module, electronic accelerator/cruise control/idle speed control module, ABS/ASR control module)
- H Data line (+)
Controller Area Network
(LH-SFI control module, ignition control module, electronic accelerator/cruise control/idle speed control module, ABS/ASR control module)

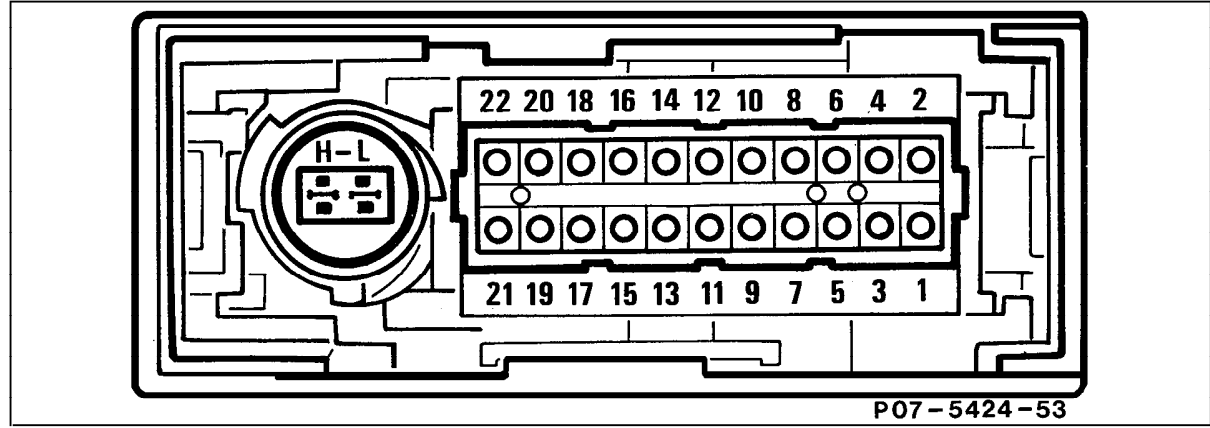

P07-5424-53