

**8.1 Models 140, 210**

	Page
<b>Diagnosis</b>	
Function Test .....	11/1
Diagnostic Trouble Code Memory .....	12/1
Complaint Related Diagnostic Chart .....	13/1
 <b>Electrical Test Program</b>	
Component Locations .....	21/1
Preparation for Test .....	22/1
Test .....	23/1

### Diagnosis – Function Test

Test step/Test sequence	Test condition	Nominal value	Possible cause/Remedy <sup>1)</sup>
⇒ 1.0 Function test	<p>PTS on/off switch (S95): <b>ON</b> (switch control LED <b>OFF</b>).</p> <p>Battery voltage: 11 - 14 V. Speedometer functioning properly Ignition: <b>ON</b></p>	<p>Quick-test: When ignition switch is turned: <b>ON</b> System functional: all segments (4, Figure 1) should illuminate for approx. 2 sec.. and the frame (3, Figure 1) should also illuminate.</p> <p> <b>Note:</b> Ensure that there are no obstacles in the front, rear, or sides of the vehicle.</p>	23 <sup>1)</sup>

<sup>1)</sup> Observe Preparation for Test, see 22.

Diagnosis – Function Test

Shown for model 140

- 1. Warning indicator in the dashboard
- 2. Warning indicator in the dome lamp
- 3. Frame
- 4. Segment
- A Red segment
- B Yellow segment

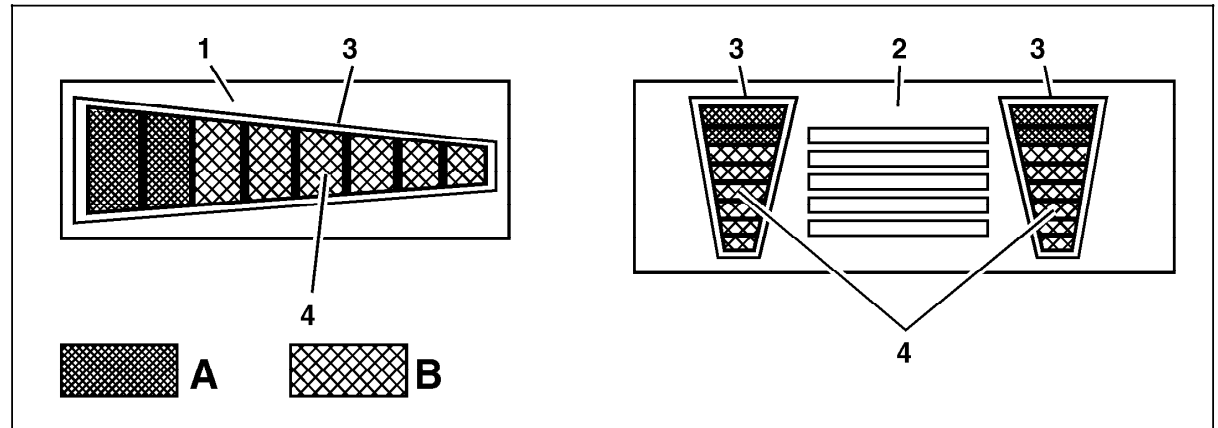

P54.65-0309-04

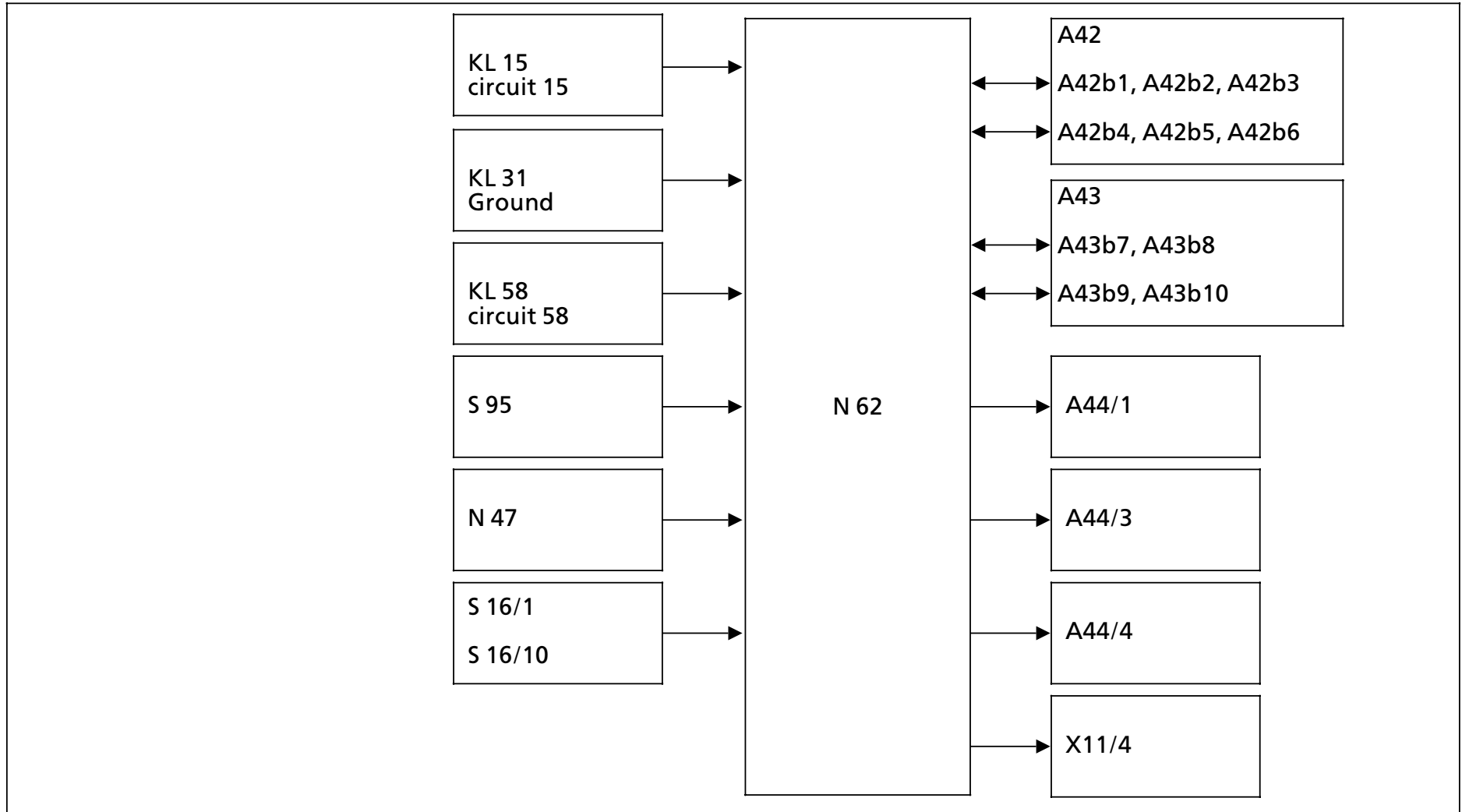

## 8.1 Parktronic System (PTS)

Models 140, 210

---

A42	PTS sensor assembly (front bumper)	A44/4	PTS warning indicator (center instrument panel air outlet)
A42b1	Left outer sensor	KI 15	Voltage supply, circuit 15
A42b2	Left center sensor	KI 31	Ground, circuit 31
A42b3	Left inner sensor	KI 58	Lights, circuit 58
A42b4	Right inner sensor	N47	Traction systems control module, VSS signal
A42b5	Right center sensor	N62	Ultrasonic PTS control module
A42b6	Right outer sensor	S16/1	Starter lock-out/backup lamp switch
A43	PTS sensor assembly (rear bumper)	S16/10	Transmission range recognition switch (voltage coded)
A43b7	Right outer sensor	S95	PTS on/off switch
A43b8	Right inner sensor	X11/4	Data link connector (DTC readout)
A43b9	Left inner sensor		
A43b10	Left outer sensor		
A44/1	PTS warning indicator(left instrument panel air outlet)		
A44/3	PTS warning indicator (rear dome lamp)		

### Diagnosis – Diagnostic Trouble Code (DTC) Memory



#### Preparation for Test

1. Connect Hand-Held Tester (HHT) to X11/4, according to diagram.
2. Ignition: **ON**
3. Read out Diagnostic Trouble Codes (DTC's) and actual values from ultrasonic PTS control module (N62).
4. Perform activations using HHT.
5. Ignition: **OFF**
6. Delete stored fault codes and repeat step 3 after 20 seconds.



#### Note:

DTC readout is not possible using impulse counter scan tool.

Perform the complete check of the Parktronic system if in case of a complaint no DTC is stored in the control module.

## Diagnosis – Complaint Related Diagnostic Chart

## Instrument Cluster

Complaint/Problem	Possible cause	Remedy/Test step <sup>1)</sup>
All red segments in the PTS warning indicator (A44/1, A44/3, and A44/4), illuminate at forward speed < approx. 9 mph; no reverse gear selected; no warning sound	Front sensors dirty; sensors defective; wires shorted or connectors not plugged-in; moisture in sensor connector; wrong sensors installed	Clean sensors Read out DTC's 12 23
Reverse gear selected; all red segments in the PTS warning indicator (A44/1, A44/3, and A44/4), illuminate at reverse speed < approx. 9 mph; no reverse gear selected; no warning sound	Rear sensors dirty; sensors defective; wires shorted or connectors not plugged-in; moisture in sensor connector; wrong sensors installed	Clean sensors Read out DTC's 12 23
All red segments in the PTS warning indicator (A44/1, A44/3, and A44/4), illuminate at speed < approx. 9 mph with no warning sound, after approx. 3 min. of interruption warning sound comes on. Interruption depends on place or time.	Interference in construction zones (pneumatic tools); moisture radiation (car wash); heavy rain, hail; electromagnetic induction (traffic light)	Switch PTS off manually using PTS on/off switch (S95) Wait for interference to cease Read out DTC's 12 23
Ultrasonic PTS control module (N62) does not store any DTC's.	No voltage supply to control module; no signal from the sensors; sensors defective or control module defective.	23
PTS system not functioning with ignition on	Fuses; Ultrasonic PTS control module (N62)	23
PTS system does not switch-on at speed < approx. 9 mph	PTS switched off manually; system became inoperative during drive	Switch PTS on and off manually using PTS on/off switch (S95); check LED in the PTS switch (S95) 23
PTS system does not switch-off at speed > approx. 9 mph	No VSS signal provided	23 ⇒ 8

<sup>1)</sup> Observe Preparation for Test, see 22.

### Diagnosis – Complaint Related Diagnostic Chart

Complaint/Problem	Possible cause	Remedy/Test step <sup>1)</sup>
Some segments of the PTS warning indicator (A44/1, A44/3, and A44/4) do not illuminate.	PTS warning indicator (A44/1, A44/3, and A44/4) defective.	Replace the PTS warning indicator (A44/1, A44/3, and A44/4).
One or more PTS warning indicator (A44/1, A44/3, and A44/4) not functioning.	No voltage supply to the respective warning indicators.	23 ⇒ 3 23 ⇒ 4 23 ⇒ 5
After switching the ignition on, the red segments of one or more warning indicator(s) (A44/1, A44/3, and A44/4) illuminate immediately without preceding function check.	Data lines to the respective warning indicator defective.	23 ⇒ 3 23 ⇒ 4 23 ⇒ 5
Rear dome lamp warning indicator (A44/3) illuminates always or is always off.	Reverse signal not correct.	23 ⇒ 9
Warning indicators too bright with lights on.	Light signal (circuit 58) not correct.	23 ⇒ 10
Front warning indicator illuminates with no obstacles in the frontal area.	System can be triggered by bushes, stones, high curbs, posts, sign etc.	System OK
System interference when wet.	Connectors to the sensors not plugged correctly; sensors not sealed correctly; harness exposed to moisture.	Repair as required.

<sup>1)</sup> Observe Preparation for Test, see 22.



## Electrical Test Program – Component Locations

- A42b1 Left outer sensor
- A42b2 Left center sensor
- A42b3 Left inner sensor
- A42b4 Right inner sensor
- A42b5 Right center sensor
- A42b6 Right outer sensor
  
- A43b7 Right outer sensor
- A43b8 Right inner sensor
- A43b9 Left inner sensor
- A43b10 Left outer sensor
  
- A44/1 PTS warning indicator (left instrument panel air outlet)
- A44/3 PTS warning indicator (rear dome lamp)
- A44/4 PTS warning indicator (center instrument panel air outlet)
  
- F3 Fuse box (35 fuse, in fuse and relay box F1)
- F4 Fuse box in trunk (17 fuse)
- N62 Ultrasonic PTS control module
- S95 PTS on/off switch
- X11/4 Data link connector DTC readout

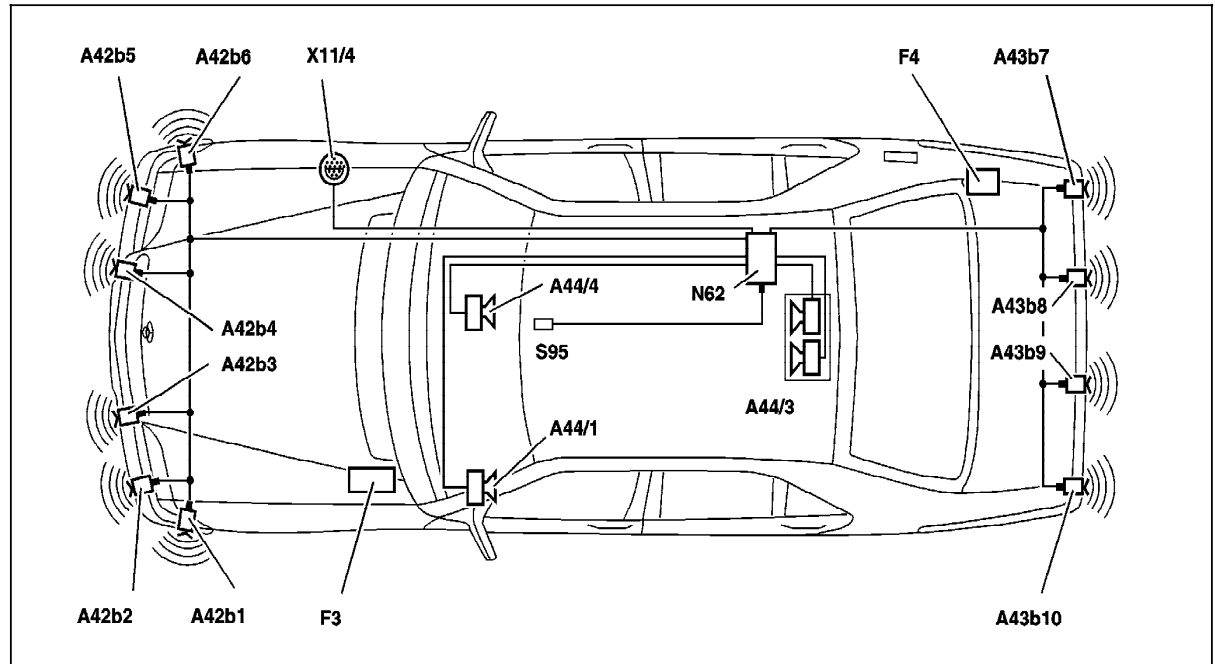

P54.65-0234-09

## Electrical Test Program – Component Locations

- A42b1 Left outer sensor
- A42b2 Left center sensor
- A42b3 Left inner sensor
- A42b4 Right inner sensor
- A42b5 Right center sensor
- A42b6 Right outer sensor
  
- A43b7 Right outer sensor
- A43b8 Right inner sensor
- A43b9 Left inner sensor
- A43b10 Left outer sensor
  
- A44/1 PTS warning indicator (left instrument panel air outlet)
- A44/3 PTS warning indicator (rear dome lamp)
- A44/4 PTS warning indicator (center instrument panel air outlet)
  
- F1 Fuse and relay box
- N62 Ultrasonic PTS control module
- S95 PTS on/off switch
- X11/4 Data link connector DTC readout

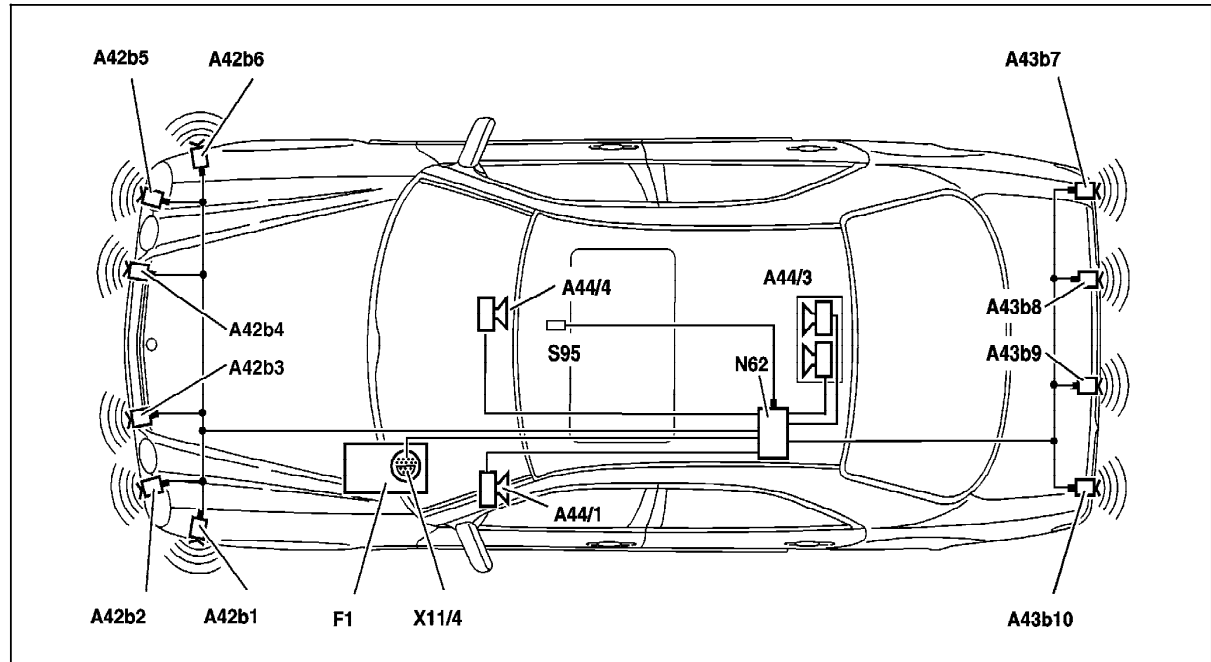

P54.65-0235-09

### Electrical Test Program - Preparation for Test

1. Ignition: **ON**
2. Read out actual values and perform activations using the HHT
3. Ignition: **OFF**
4. Connect socket box and test cable according to connection diagram (Figure 1)

**Note:**

Use recommended multimeter (refer to 22/2) equipped with an analog bar graph display.

5. After completing repairs on the PTS:
  - Erase DTC's
  - Wait 20 seconds (the existing fault[s] will be erased after 20 seconds).

Electrical wiring diagrams:

Electrical Trouble Shooting Manual (ETM) Model 140 and 210

**Note:**

When replacing the Ultrasonic PTS control module (N62), the control module must be version coded using the HHT. Follow instruction as indicated in the HHT display.

Electrical Test Program - Preparation for Test

Special Tools

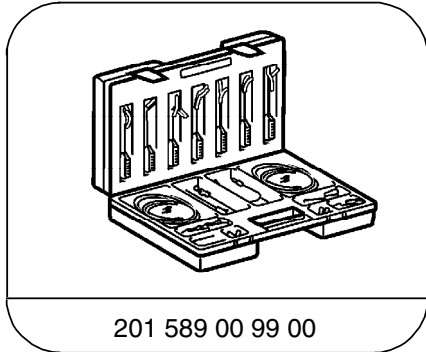

201 589 00 99 00

Electrical connecting set

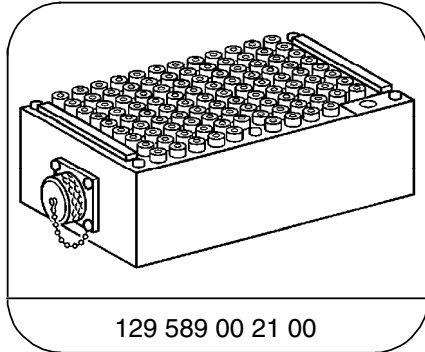

129 589 00 21 00

126-pin socket box

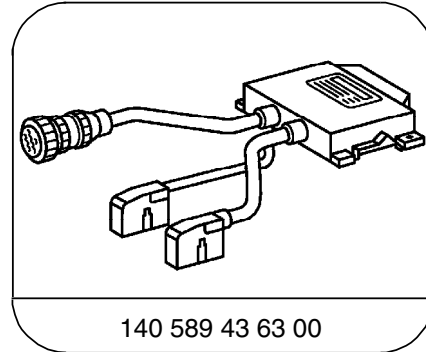

140 589 43 63 00

Test cable, 30-pin

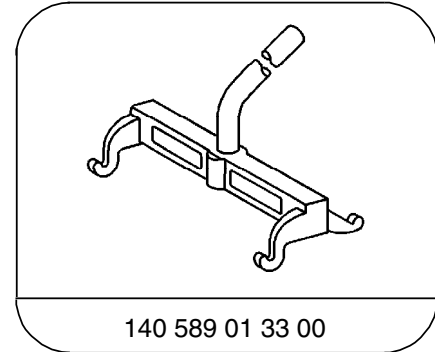

140 589 01 33 00

Mounting lever

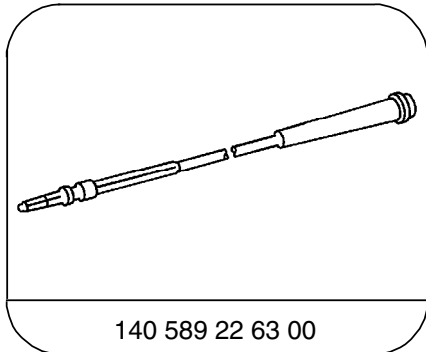

140 589 22 63 00

Adapter cable

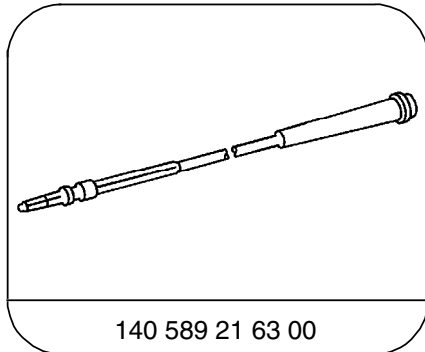

140 589 21 63 00

Adapter cable

Conventional tools, test equipment

Description	Brand, model, etc.
Multimeter <sup>1)</sup>	Fluke models <sup>2)</sup> 23, 83, 88

<sup>1)</sup> Available through the MBUSA Standard Service Equipment Program.

<sup>2)</sup> Only multimeters with analog display can be used

Electrical Test Program - Preparation for Test

Connection Diagram - Socket Box

**Note:**

When testing, use a recommended multimeter (refer to 22/2) equipped with an analog bar graph display.

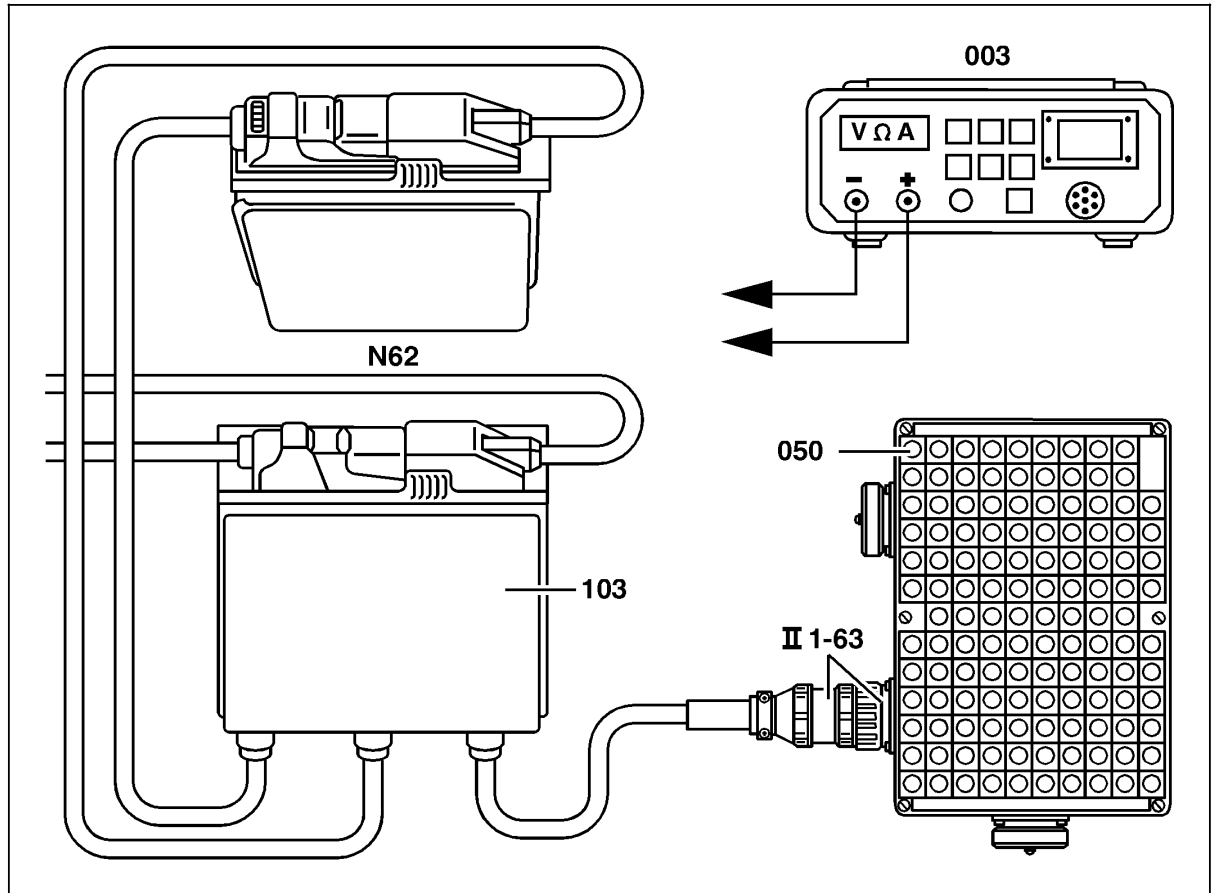

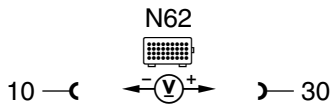
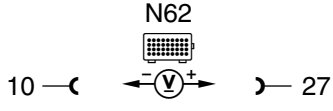

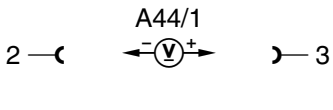
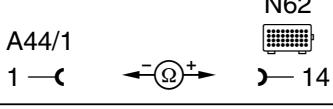



Figure 1



- 003 Multimeter
- 050 Socket box (126 pole)
- 103 Test cable
- N62 Ultrasonic PTS control module

P54.65-0310-06

## Electrical Test Program – Test

⇒		Test scope	Test connection	Test condition	Nominal value	Possible cause/Remedy
1.0		<b>Ultrasonic PTS control module (N62)</b> Voltage supply		Ignition: <b>ON</b>	11 - 14 V	Model 140: Fuse 4 in fuse box F4 Models 208, 210: Fuse 14 in fuse and relay box F1 Wiring
2.0		Diagnostic output		Ignition: <b>ON</b>	9 - 14 V	Wiring N62
3.0		<b>PTS warning indicator (left instrument panel air outlet) (A44/1)</b>		Ignition: <b>ON</b> Activate warning indicator using HHT	All yellow and red segments in the warning indicator <b>Illuminate</b>	Wiring A44/1 N62 ⇒ 3.1
3.1		Voltage supply		Disconnect connector from PTS warning indicator (A44/1) Ignition: <b>ON</b>	11 - 14 V	Wiring N62 ⇒ 3.2
3.2		Data line		Ignition: <b>OFF</b>	< 1 Ω	Wiring
4.0		<b>PTS warning indicator (center instrument panel air outlet) (A44/4)</b>		Ignition: <b>ON</b> Activate warning indicator using HHT	All yellow and red segments in the warning indicator <b>Illuminate</b>	Wiring A44/4 N62 ⇒ 4.1

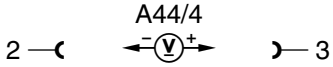
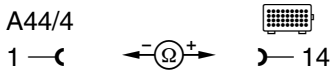
## Electrical Test Program – Test

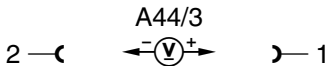
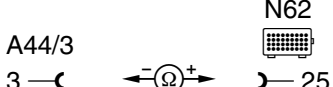
⇒		Test scope	Test connection	Test condition	Nominal value	Possible cause/Remedy
4.1		Voltage supply		Disconnect connector from (A44/4) Ignition: <b>ON</b>	11 - 14 V	Wiring N62 ⇒ 4.2
4.2		Data line		Ignition: <b>OFF</b>	< 1 Ω	Wiring
5.0		<b>PTS warning indicator (rear dome lamp) (A44/3)</b>		Ignition: <b>ON</b> Activate warning indicator using HHT	All yellow and red segments in the warning indicator <b>Illuminate</b>	Wiring A44/3 N62 ⇒ 5.1
5.1		Voltage supply		Disconnect connector from PTS warning indicator (A44/3) Ignition: <b>ON</b>	11 - 14 V	Wiring N62 ⇒ 5.2
5.2		Data line		Ignition: <b>OFF</b>	< 1 Ω	Wiring

## Electrical Test Program – Test

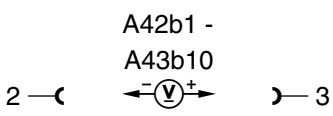
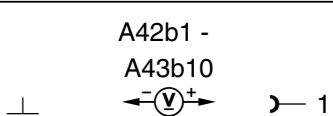
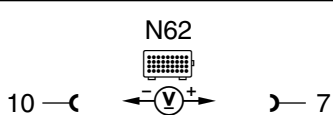
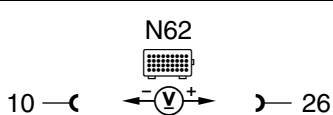
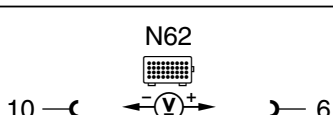
⇒		Test scope	Test connection	Test condition	Nominal value	Possible cause/Remedy
6.0	B1246 B1247 B1248 B1249 B1250 B1251 B1252 B1253 B1254 B1255	<b>PTS sensor assembly (front or rear bumper) (A42b1 - A43b10)</b> Voltage supply		Disconnect connector from A42b1 - A43b10 Ignition: <b>ON</b>	Models 140 and 210: 18 - 20 V Model 208: 7.5 - 9.5 V	Wiring N62 ⇒ 6.1
6.1		Data line		Ignition: <b>ON</b> Activate data line using HHT	Bar graph in multimeter pulses	Wiring N62
7.0		Vehicle speed signal VSS		Ignition: <b>ON</b> Rotate left front wheel	> 3 V	Wiring
8.0		Reverse signal		Ignition: <b>ON</b> Select reverse gear	> 7.5 V	Wiring Starter lock-out/backup lamp switch (S16/1) Transmission range recognition switch (S16/10)
9.0		Light signal (circuit 58)		Ignition: <b>ON</b> Lights: <b>ON</b>	> 7.5 V	Wiring