

Electrical Test Program - Preparation for Test

1. Ignition: **ON**
2. Read out actual values and perform activations using the HHT
3. Ignition: **OFF**
4. Connect socket box and test cable according to connection diagram (Figure 1)

Note:

Use recommended multimeter (refer to 22/2) equipped with an analog bar graph display.

5. After completing repairs on the PTS:
 - Erase DTC's
 - Wait 20 seconds (the existing fault[s] will be erased after 20 seconds).

Electrical wiring diagrams:

Electrical Trouble Shooting Manual (ETM) Model 140 and 210

Note:

When replacing the Ultrasonic PTS control module (N62), the control module must be version coded using the HHT. Follow instruction as indicated in the HHT display.

Electrical Test Program - Preparation for Test

Special Tools

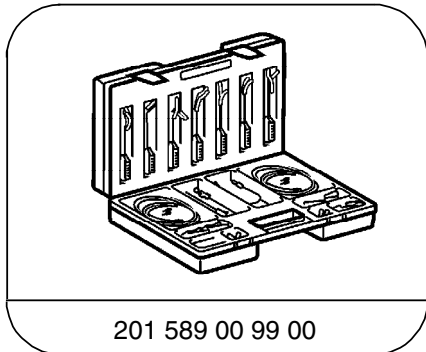

201 589 00 99 00

Electrical connecting set

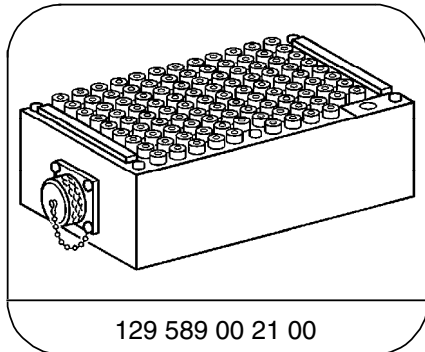

129 589 00 21 00

126-pin socket box

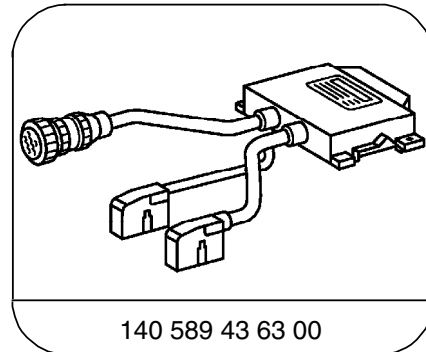

140 589 43 63 00

Test cable, 30-pin

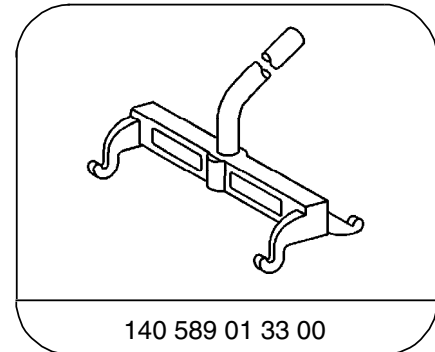

140 589 01 33 00

Mounting lever

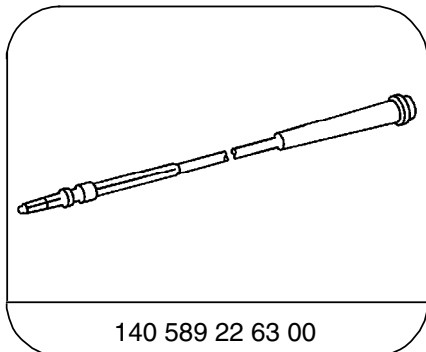

140 589 22 63 00

Adapter cable

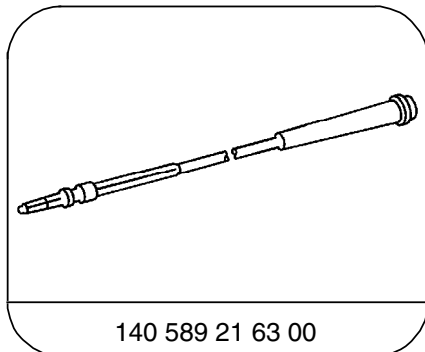

140 589 21 63 00

Adapter cable

Conventional tools, test equipment

Description	Brand, model, etc.
Multimeter ¹⁾	Fluke models ²⁾ 23, 83, 88

¹⁾ Available through the MBUSA Standard Service Equipment Program.

²⁾ Only multimeters with analog display can be used

Electrical Test Program - Preparation for Test

Connection Diagram - Socket Box

Note:

When testing, use a recommended multimeter (refer to 22/2) equipped with an analog bar graph display.

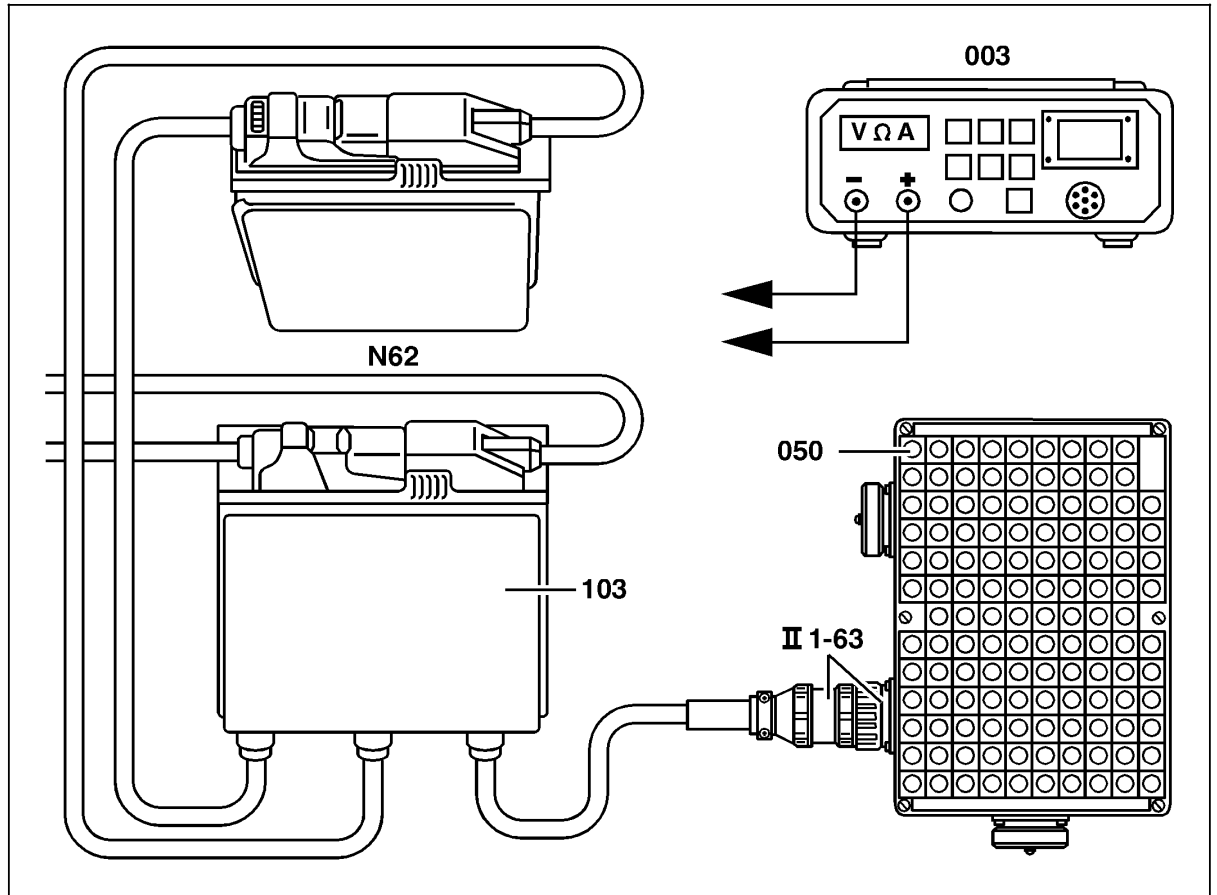

Figure 1

- 003 Multimeter
- 050 Socket box (126 pole)
- 103 Test cable
- N62 Ultrasonic PTS control module

P54.65-0310-06