

Electrical Test Program - Preparation for Test (Backup Assist)

Preliminary work:

Diagnosis - Diagnostic Trouble Code (DTC) Memory 11 PSE

Preparation for Test:

1. Check fuse F4-3 and fuse F4-11.
2. Provide access to PSE control module (A37, A37/1).
3. Connect socket box with test cable according to connection diagram, see 22 Fig.1.

Electrical wiring diagrams

See Electrical Troubleshooting Manual, Model 140, Volume 2.

Special Tools

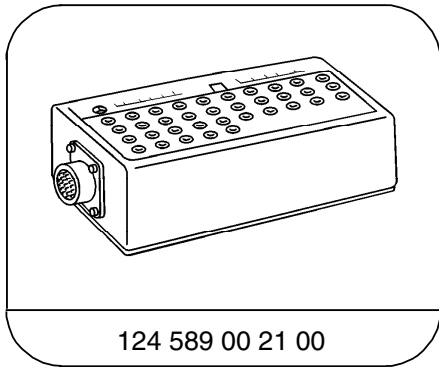

124 589 00 21 00

35-pin socket box

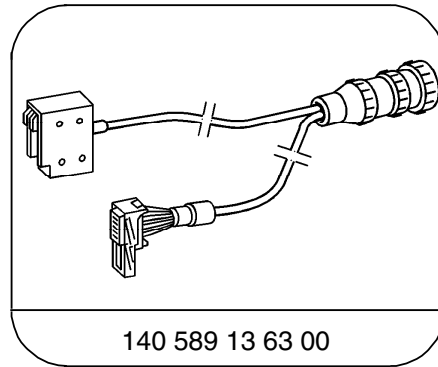

140 589 13 63 00

21-pin test cable

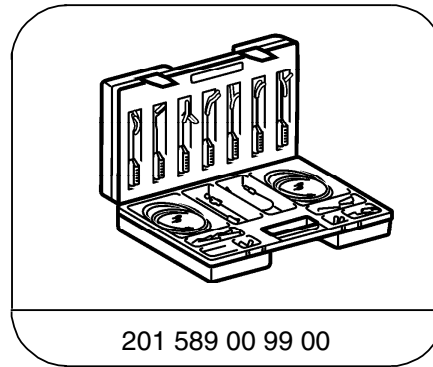

201 589 00 99 00

Electrical connecting set

Equipment

Multimeter ¹⁾	Fluke models 23, 83, 85, 87
--------------------------	-----------------------------

¹⁾ Available through the MBUSA Standard Equipment Program.

Electrical Test Program - Preparation for Test (Backup Assist)

Connection Diagram - Socket Box

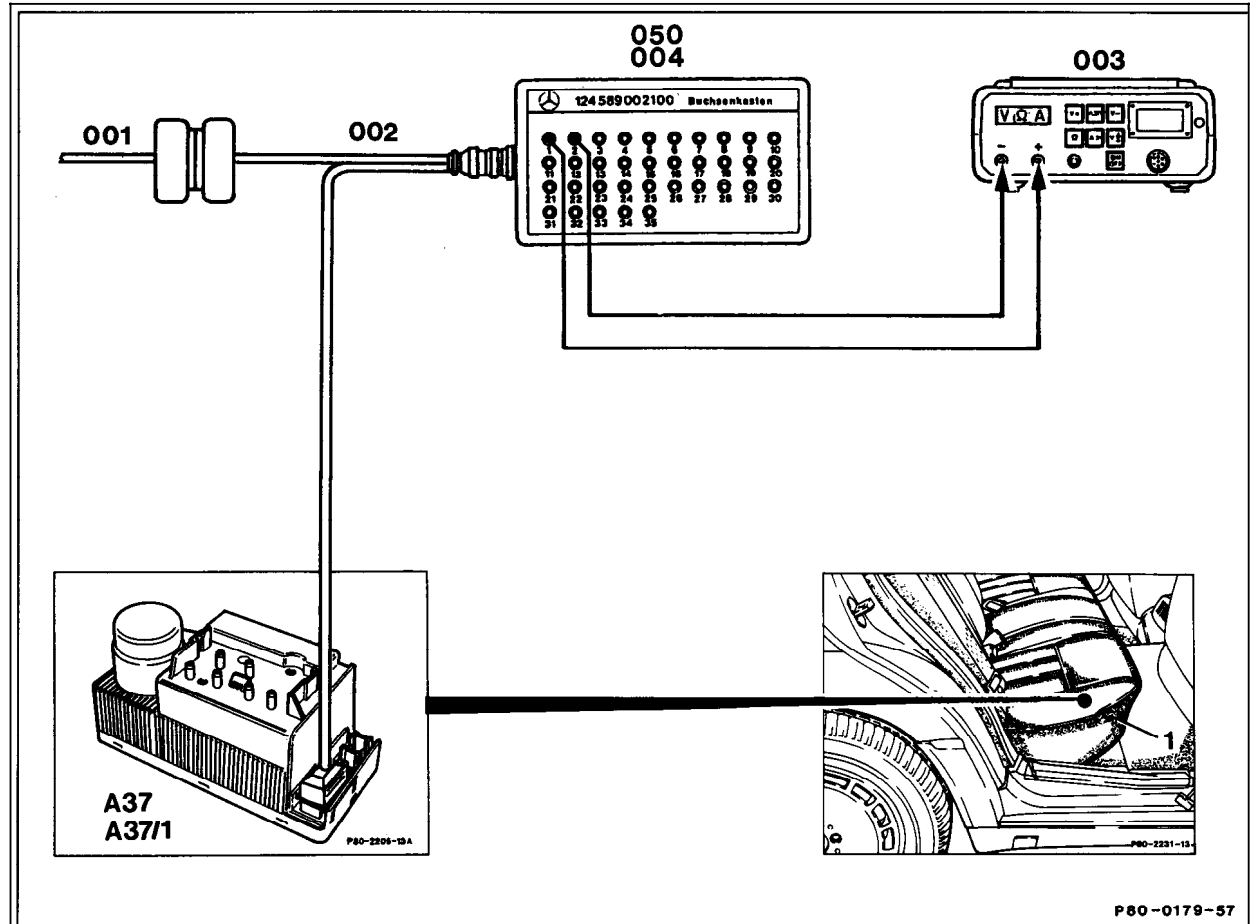

Figure 1

- 001 PSE control module connector
- 002 Test cable
- 003 Multimeter
- 004/050 Socket box (35-pole)
- A37, A37/1 PSE control module

P80-0179-57

P80-0179-57