

Electrical Test Program – Preparation for Test

Preparation for Test:

1. Remove A/C pushbutton control module (N19), see AR83.25-P-1120F
2. Review "Connection Diagram - Socket box", 22/2



Upon completion of test, erase DTC memory from A/C pushbutton control module (N19) (see section 0).

Electrical wiring diagrams:

Electrical Troubleshooting Manual, Model 202/208, Vol. 2, Group 83.

Special Tools

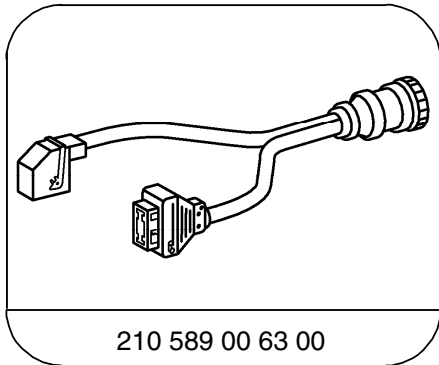

210 589 00 63 00

29-pin test cable

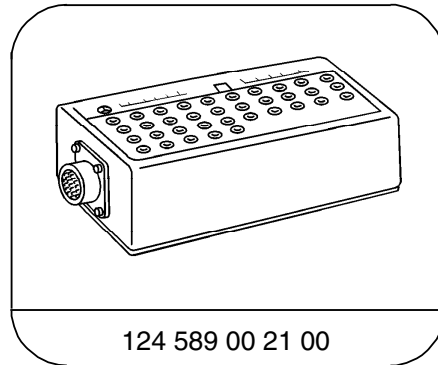

124 589 00 21 00

35-pin socket box

Test equipment; See MBUSA Standard Service Equipment Program

Description	Brand, model, etc.
Digital multimeter	Fluke models 23, 77 III, 83, 85, 87

Electrical Test Program - Preparation for Test

Connection Diagram - Socket box

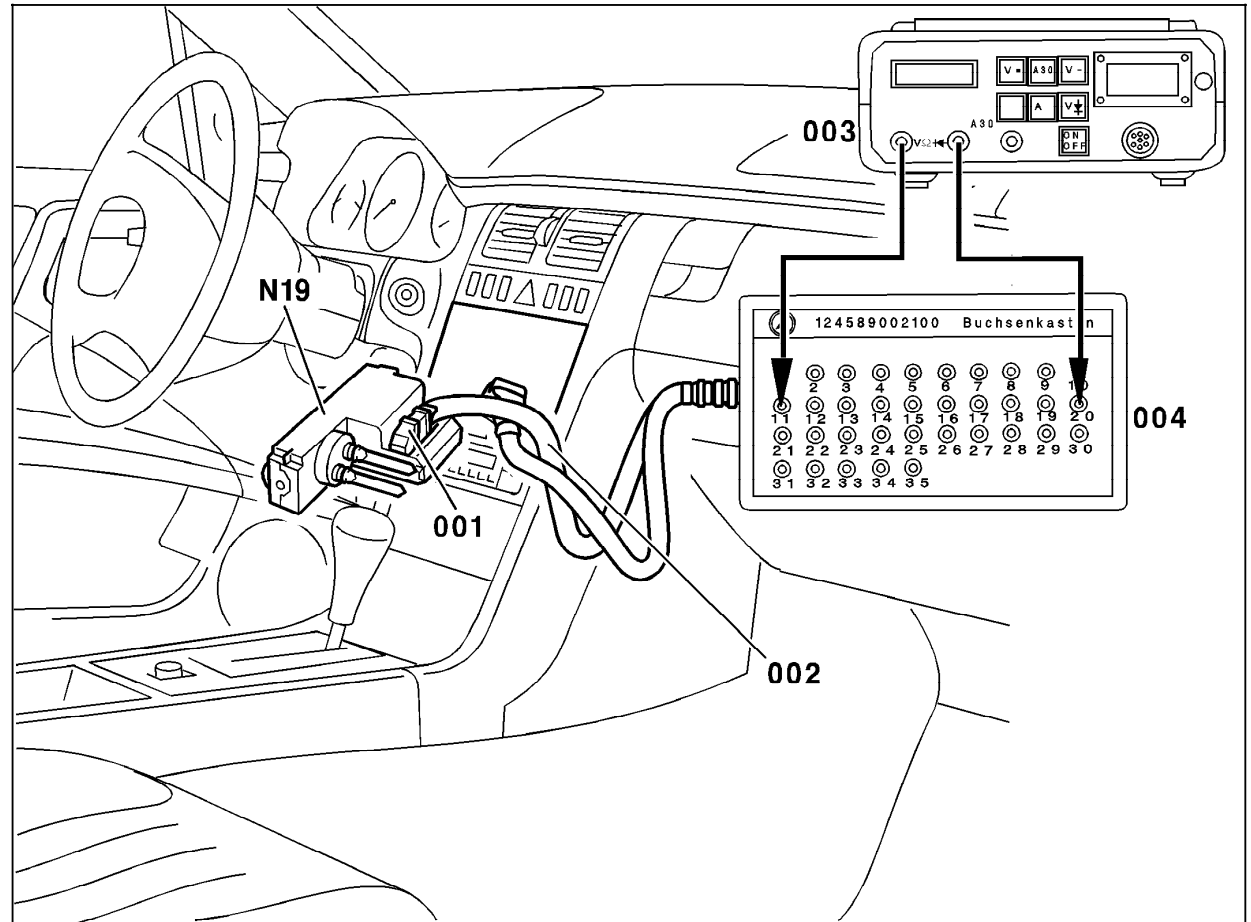

Figure 1

- 001 Right connector, A/C pushbutton control module
- 002 Test cable
- 003 Multimeter
- 004 Socket Box
- N19 A/C pushbutton control module

P83.30-0357-06