

Pneumatic Test Program – Component Locations

Location of Components

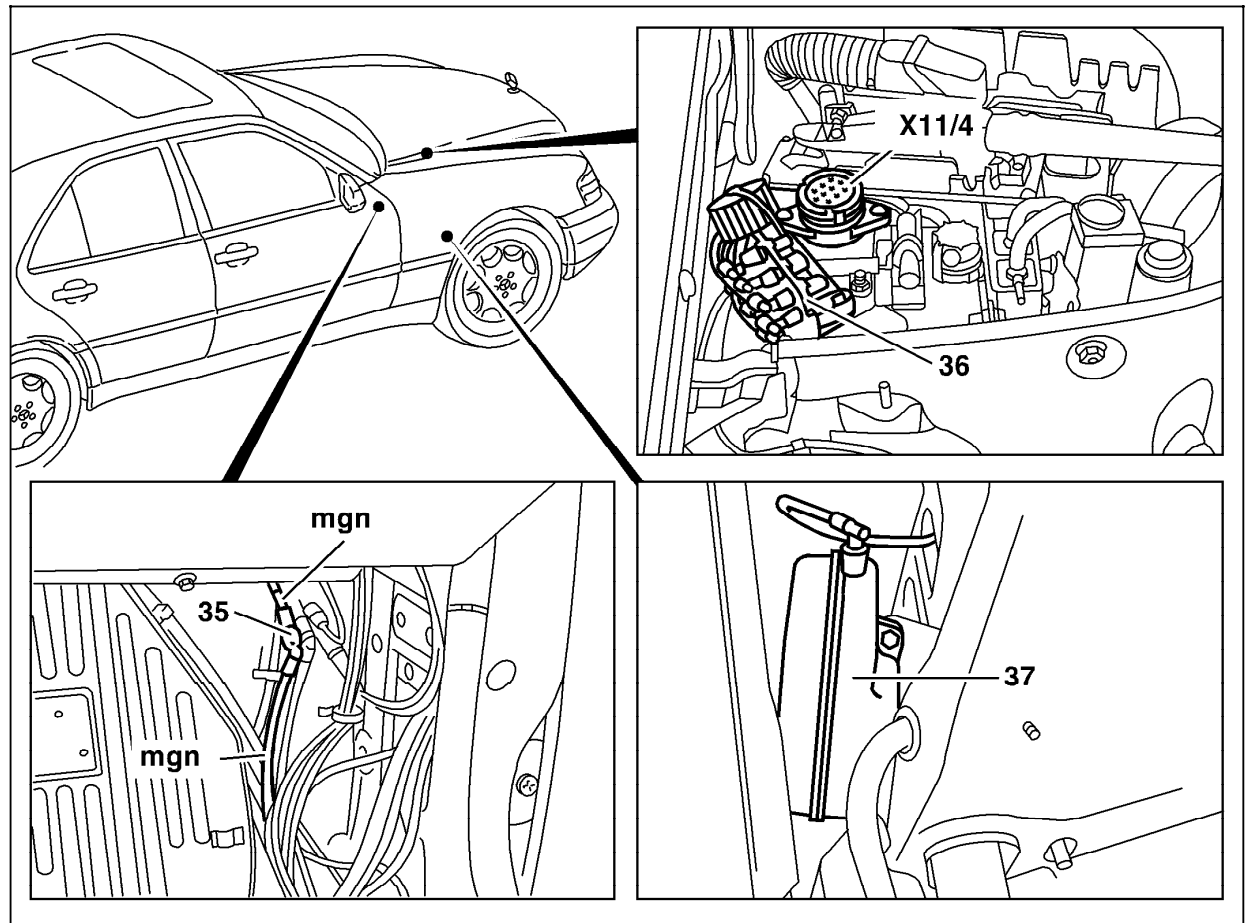

Figure 1

36 Vacuum distributor block

P83.30-3101-06

Pneumatic Test Program – Component Locations

Location of Components

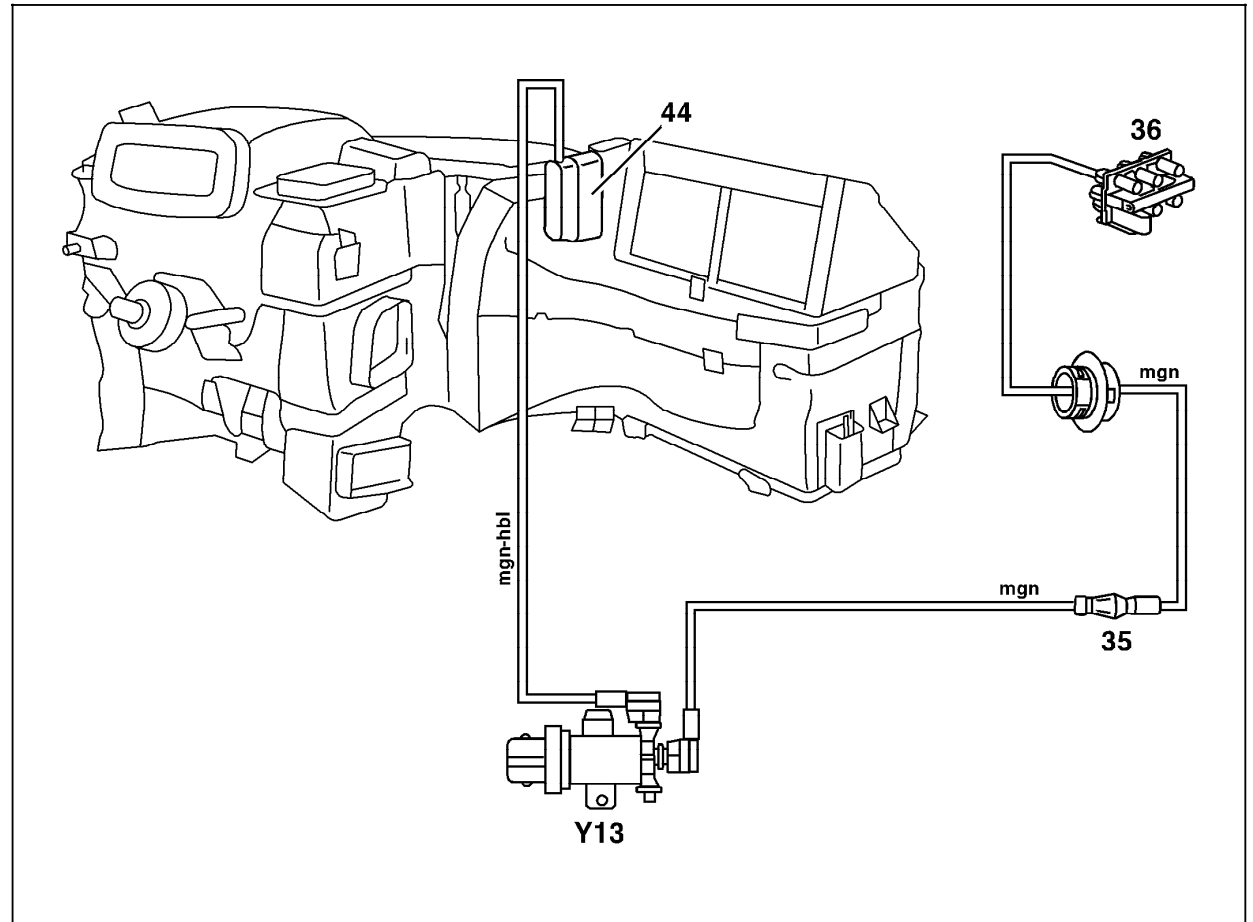

Figure 2

- 35 Separation fitting (cockpit)
- 36 Vacuum distributor block
- Y13 Fresh/recirculated air flap switchover valve
- mgn Medium green

P83.10-2006-06