

Hydraulic Test Program – Preparation for Test (Injector Test)

Preparation for Test

1. Review section 0,
2. Review 11, 21, 22, 23, 24, 31, 33,
3. Connect socket box tester to engine control module (N3/10).
4. Disconnect 2-pole connectors on injectors.
5. Remove fuel rail with injectors, thereby **not** disconnecting the fuel feed and return lines.
6. Connect self-made harness (048), see 35/3, to each injector one after another.
7. Hold each injector in measuring glass one after another.



When disconnecting the connectors on the engine control module remove center connector (D) first, when reconnecting connectors install center connector (D) last.

Figure 1

001	Engine control module connectors A-F
048	Self made harness
050	Socket box tester, 126 pole
055	Measuring glass
108	Test cable
N3/10	Engine control module (ME-SFI)
A - F	Connectors
II1/63	Connectors, socket box
III64/126	Connectors, socket box

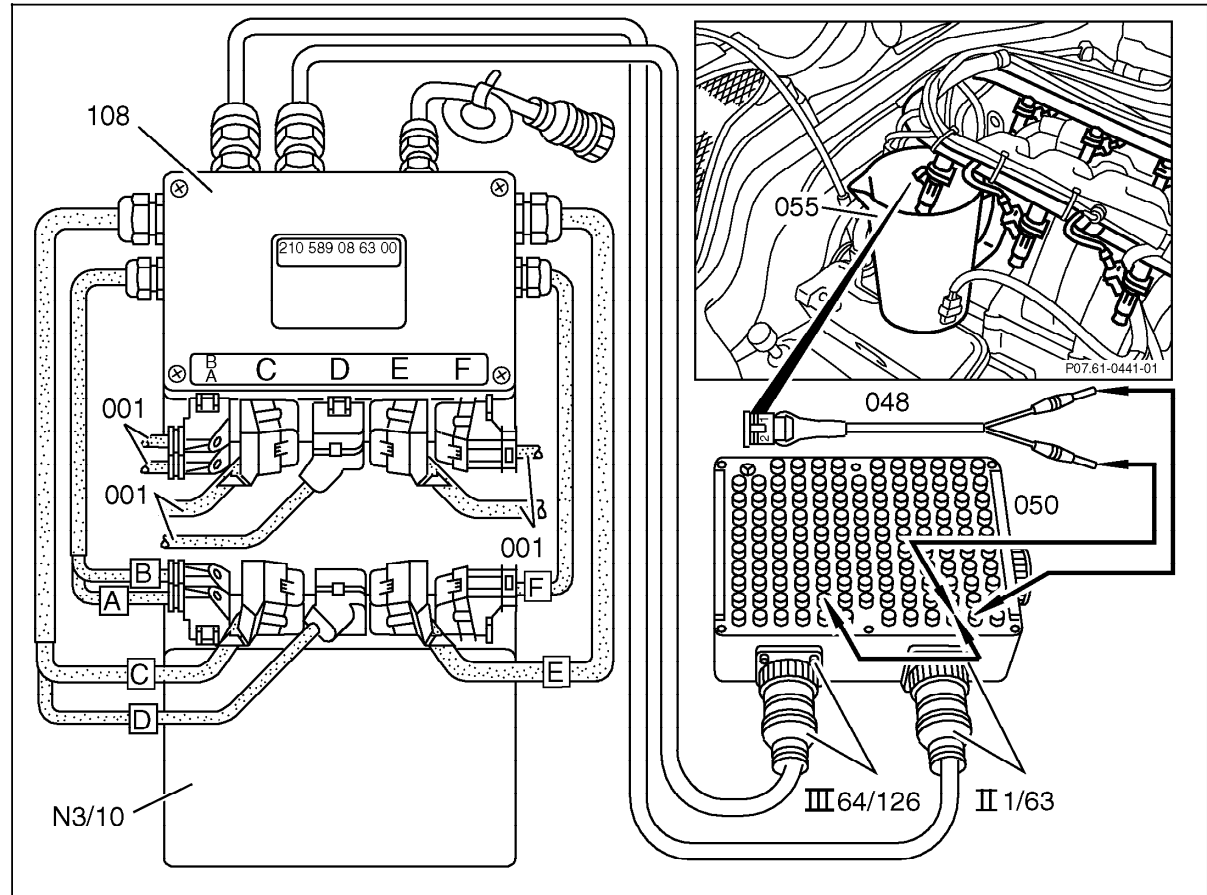

P07.61-0464-06

Hydraulic Test Program – Preparation for Test (Injector Test)

Special Tools

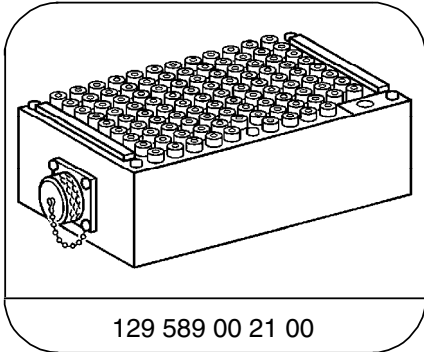

129 589 00 21 00

126-pin socket box

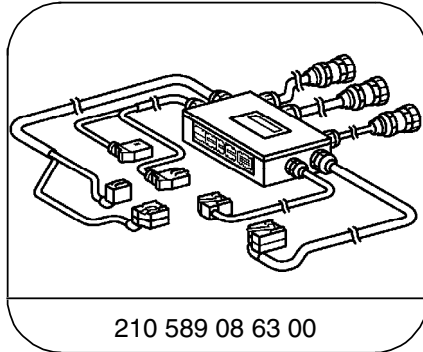

210 589 08 63 00

145-pin test cable

Conventional tools, test equipment

Description	Brand, model, etc.
Measuring glass (1 liter minimum)	Local purchase

Hydraulic Test Program – Preparation for Test (Injector Test)

Self made harness

Consists of:

- 1x Connector (140 545 35 28)
- 2x Contact spring (004 545 56 26)
- 1x Banana plug (red)
- 1x Banana plug (black)
- 2.2m Wire (red, 1.5 mm)
- 2.2m Wire (brown, 1.5 mm)
- 2.2m Harness tubing (6mm diameter)

Connector layout  
 1=red  
 2=brown

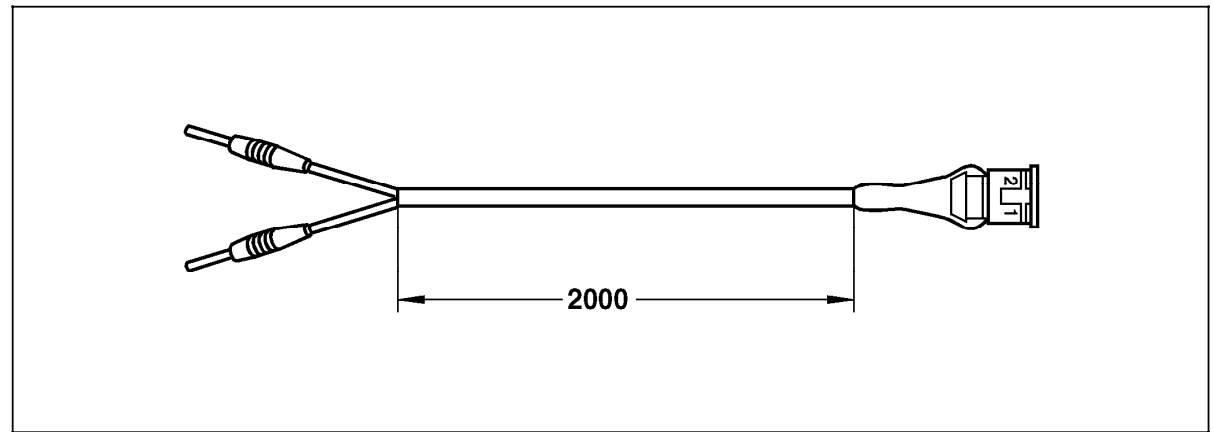

P07.61-0541-10